



## **SINGLE DRUM ROLLER**

*SERVICE MANUAL SM96106*

July 2004

**Model VM 106**

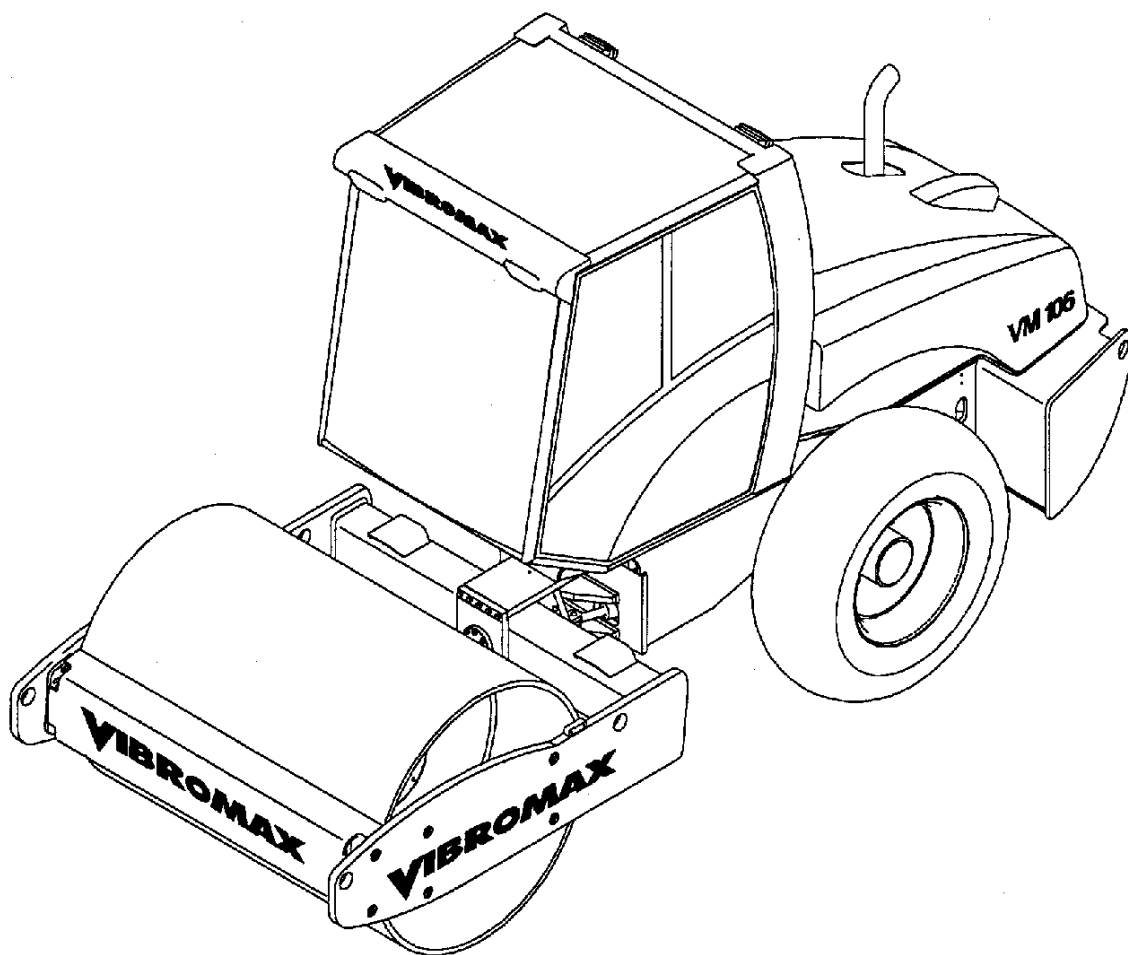



**CALIFORNIA**

**Proposition 65 Warning**

Diesel engine exhaust and some of its constituents are known to the State of California to cause cancer, birth defects, and other reproductive harm.

# SECTION ONE

## GENERAL INFORMATION

MACHINE DESCRIPTION .....	1 - 3
SERIAL NUMBERS.....	1 - 5
IDENTIFYING MACHINE COMPONENTS .....	1 - 6
FLUID SPECIFICATIONS.....	1 - 7
MACHINE SPECIFICATIONS.....	1 - 8
STANDARD TORQUE DATA.....	1 - 10
DIESEL FUEL SPECIFICATION.....	1 - 12
ENGINE OIL SPECIFICATION.....	1 - 13
SAFETY, GENERAL.....	1 - 14
SPARK ARRESTER .....	1 - 14
PERSONAL.....	1 - 15
MACHINE OPERATION .....	1 - 16
MAINTENANCE .....	1 - 19
MAINTENANCE SCHEDULE .....	1 - 23

# SECTION TWO

## ENGINE

CUMMINS ENGINE WARRANTY.....	2 - 2
------------------------------	-------

# SECTION THREE

## ELECTRICAL

GENERAL INFORMATION.....	3 - 3
FUSES .....	3 - 4
RELAYS.....	3 - 5
INSTRUMENT PANEL.....	3 - 6
UNDERSTANDING ELECTRICAL SCHEMATICS.....	3 - 11
UNDERSTANDING RELAYS.....	3 - 14
STARTER/CHARGING CIRCUIT .....	3 - 17
EMERGENCY STOP .....	3 - 17
UNDERSTANDING BATTERIES.....	3 - 17
UNDERSTANDING ALTERNATORS .....	3 - 19
UNDERSTANDING STARTERS.....	3 - 22
INSTRUMENTATION PANEL.....	3 - 27
BRAKE SWITCH.....	3 - 29
HIGH SPEED CIRCUIT .....	3 - 31
VIBRATION CIRCUIT .....	3 - 33
ROAD LIGHTING CIRCUIT .....	3 - 35

WORK LIGHTS & ACCESSORY PLUG .....	3 - 37
CAB CIRCUITS .....	3 - 39
ELECTRICAL SCHEMATICS .....	3 - 40
PLUG CONNECTORS.....	3 - 48
INSTRUMENT HARNESS 7242/80435 .....	3 - 49
WIRE CHART 7242/80435 .....	3 - 51
RELAY/FUSE HARNESS 7242/80415 .....	3 - 54
WIRE CHART 7242/80415 .....	3 - 56
REAR HARNESS 7222/80510.....	3 - 60
WIRE CHART 7222/80510 .....	3 - 62

## SECTION FOUR

### HYDRAULIC

HYDRAULIC COOLER LINES.....	4 - 2
HYDRAULIC DRAIN LINES.....	4 - 5
HYDRAULIC CHARGE SYSTEM .....	4 - 7
HYDRAULIC TEST STATION.....	4 - 9
HYDRAULIC TEST FITTINGS.....	4 - 10
PROPULSION SYSTEM.....	4 - 11
PROPULSION SCHEMATIC .....	4 - 13
PROPULSION SYSTEM DIAGNOSTICS.....	4 - 15
VIBRATION SYSTEM .....	4 - 17
VIBRATORY SYSTEM DIAGNOSTICS.....	4 - 19
VIBRATION SYSTEM SCHEMATIC.....	4 - 20
STEERING SYSTEM .....	4 - 21
STEERING SYSTEM SCHEMATIC.....	4 - 23
PARKING BRAKE SYSTEM .....	4 - 25
PARKING BRAKE SCHEMATIC.....	4 - 27
TOWING YOUR MACHINE .....	4 - 29
TOWING PROCEDURE.....	4 - 30
PUMP CONTROL VALVE.....	4 - 31
HYDRAULIC COMPONENTS.....	4 - 33
HYDRAULIC SCHEMATIC .....	4 - 34

## SECTION FIVE

### POWER TRAIN

DRUM ASSEMBLY .....	5 - 2
DRUM REMOVAL.....	5 - 6
DRUM INSTALLATION.....	5 - 6
RIGHT SIDE BEARING COVER.....	5 - 7
DRUM DRIVE BEARING REMOVAL.....	5 - 7

DRUM DRIVE BEARING ASSEMBLY .....	5 - 9
DRUM DRIVE MOTOR REPAIRS .....	5 - 10
DRUM DRIVE GEARBOX.....	5 - 11
GFT 17 T2/312 2 GEARBOX .....	5 - 13

## SECTION SIX

### PARKING BRAKE SYSTEM

PARKING BRAKE SYSTEM .....	6 - 2
PARKING BRAKE SCHEMATIC.....	6 - 4
TOWING YOUR MACHINE .....	6 - 6
TOWING PROCEDURE.....	6 - 7

## SECTION SEVEN

### VIBRATION SYSTEM

LIFTING DEVICE .....	7 - 2
DRUM EXCITER SHAFT .....	7 - 3
VIBRATION SYSTEM .....	7 - 4
VIBRATION SYSTEM SCHEMATIC.....	7 - 5
VIBRATION FREQUENCY .....	7 - 6
VIBRATION AMPLITUDE .....	7 - 7
VIBRATORY SYSTEM DIAGNOSTICS.....	7 - 8
DRUM DRAWING .....	7 - 9
DRUM - LEFT SIDE .....	7 - 10
DRUM - RIGHT SIDE.....	7 - 11
DRUM REMOVAL.....	7 - 13
DRUM INSTALLATION.....	7 - 13
RIGHT SIDE BEARING COVER.....	7 - 14
EXCITER BEARING REMOVAL.....	7 - 15
EXCITER BEARING ASSEMBLY .....	7 - 17

## SECTION EIGHT

### STEERING SYSTEM

SPECIAL TOOLS.....	8 - 2
ARTICULATION JOINTS .....	8 - 3
JOINT DISASSEMBLY .....	8 - 5
JOINT ASSEMBLY .....	8 - 9

## **SECTION NINE**

### **CHASSIS**

## **SECTION TEN**

### **ATTACHMENTS**

ROLL OVER PROTECTION STRUCTURE (ROPS) .....	10 - 2
ROPS TIGHTENING TORQUES .....	10 - 2

# SECTION ONE

## GENERAL INFORMATION





## MACHINE DESCRIPTION

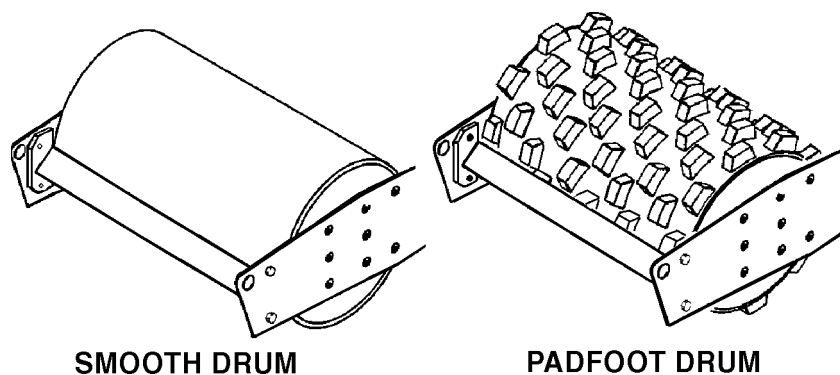
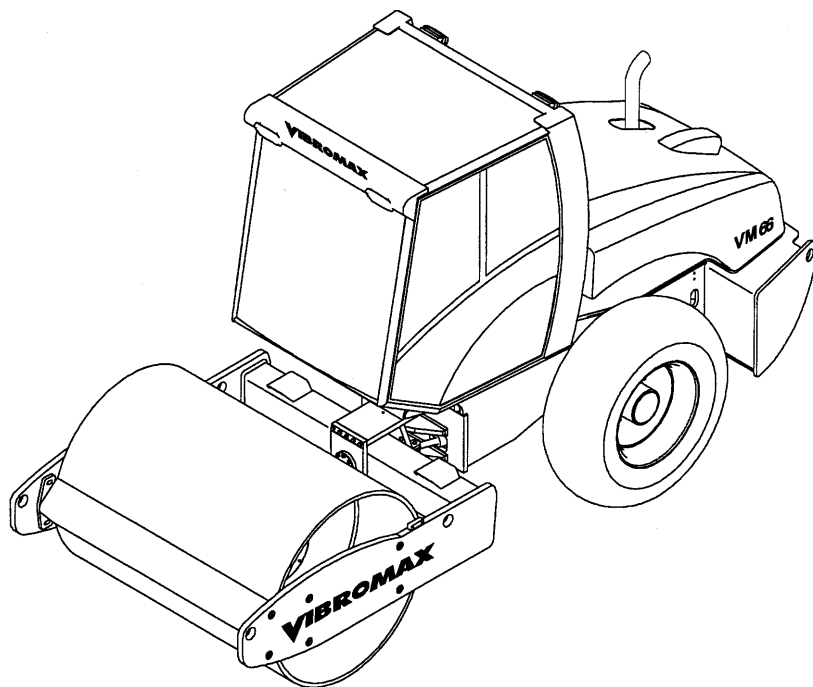

SMOOTH DRUM

PADFOOT DRUM

This book introduces the new Vibromax 6 series single drum rollers. Included within the pages of the book are materials covering the Model VM106.

The new roller uses the Cummins 3.9 liter 4 cylinder engine. The engine is turbocharged and tuned to meet the latest EPA emissions standards.

A Mannesman Rexroth variable displacement, axial piston hydrostatic pump, used for machine propulsion, is mounted to the flywheel end of the engine. It provides oil to a Rexroth 2 speed drum drive motor and a 2 speed axle drive motor in a parallel path. The Rexroth drum motor is mounted on the left side of the drum, drives through a L&S planetary gearbox and is isolated from the drum by rubber buffers. This arrangement is used in the heavy roller models with a great deal of success. The axle drive motor is attached directly to the intermediate gearbox incorporated into the rear axle.

**Buy Now**



Our support email:

[ebooklibonline@outlook.com](mailto:ebooklibonline@outlook.com)