

Document Title: Engine control unit D12, E-ECU, description of function	Function Group: 200	Information Type: Service Information	Date: 2014/8/22
Profile: ART, A35D [GB]			

Engine control unit D12, E-ECU, description of function

Control unit sensors

The unit injectors in the D12 engine are controlled entirely electronically regarding amount of injected fuel and injection timing. The system is called EMS (Engine Management System).

The following is a brief summary of the parts on the engine. There are a number of other parts that affect the system, for example, the throttle pedal sensor.

The central part of the system, the control unit, A, is positioned on the left side of the engine. All cable connectors for the sensors of the engine are of the DIN standard and are connected in a so called cable terminal, B.

The cable terminal, which is positioned above the control unit, is made of plastic and is in three parts. The inner part nearest the engine contains all cables and connectors that concern the engine. On the outside of these there is a partition (C) and an outer cover (D). On the inside of the outer cover there is room for other cable harnesses that belong to the machine.

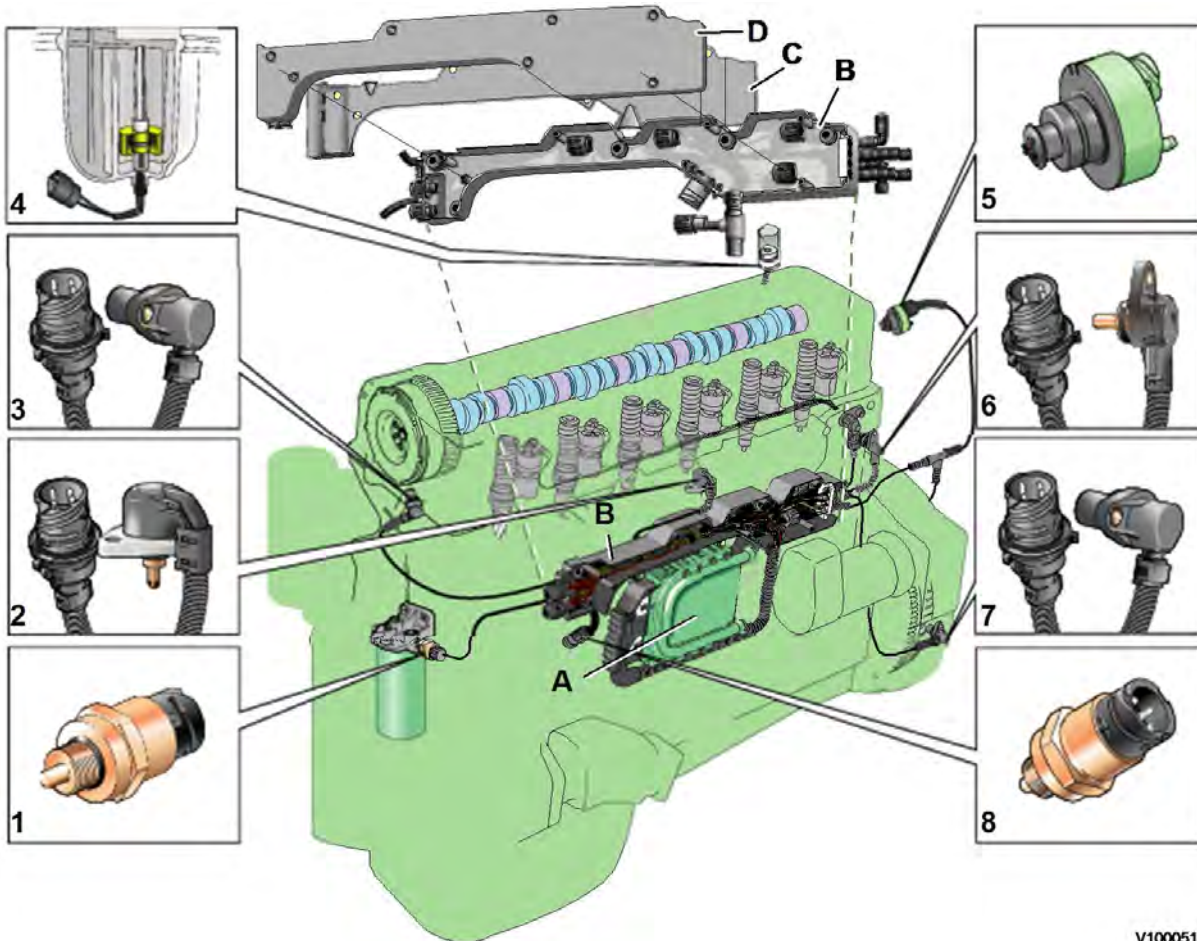

V1000518

Figure 1
D12C. Engine sensors (some have dual functions)

1. Fuel pressure. Positioned on the fuel filter bracket. Senses feed pressure after the filter, SE2301 (PID 94).
2. Charge air pressure and charge air temperature. Combined sensor positioned on the inlet manifold, SE2507 (PID

105), SE2508 (PID 102).

3. Camshaft position. Positioned near the top of the cylinder head at the front, SE2703 (SID 21).
4. Coolant level. Positioned in the expansion tank, SE2603 (PID 111).
5. Air pressure and air temperature. Combined sensor, positioned on the connecting pipe between the air filter and the turbocharger, SE2501 (PID 172), SE2502 (PID 107).
6. Coolant temperature. Positioned in the rear end of the cylinder head, SE2606 (PID 110).
7. Flywheel position and rotational speed. Positioned in the flywheel housing, SE2701 (SID 22).
8. Oil pressure and oil temperature. Combined sensor positioned in the lubrication system main duct in the cylinder block, SE2202 (PID 175), SE2203 (PID 100).

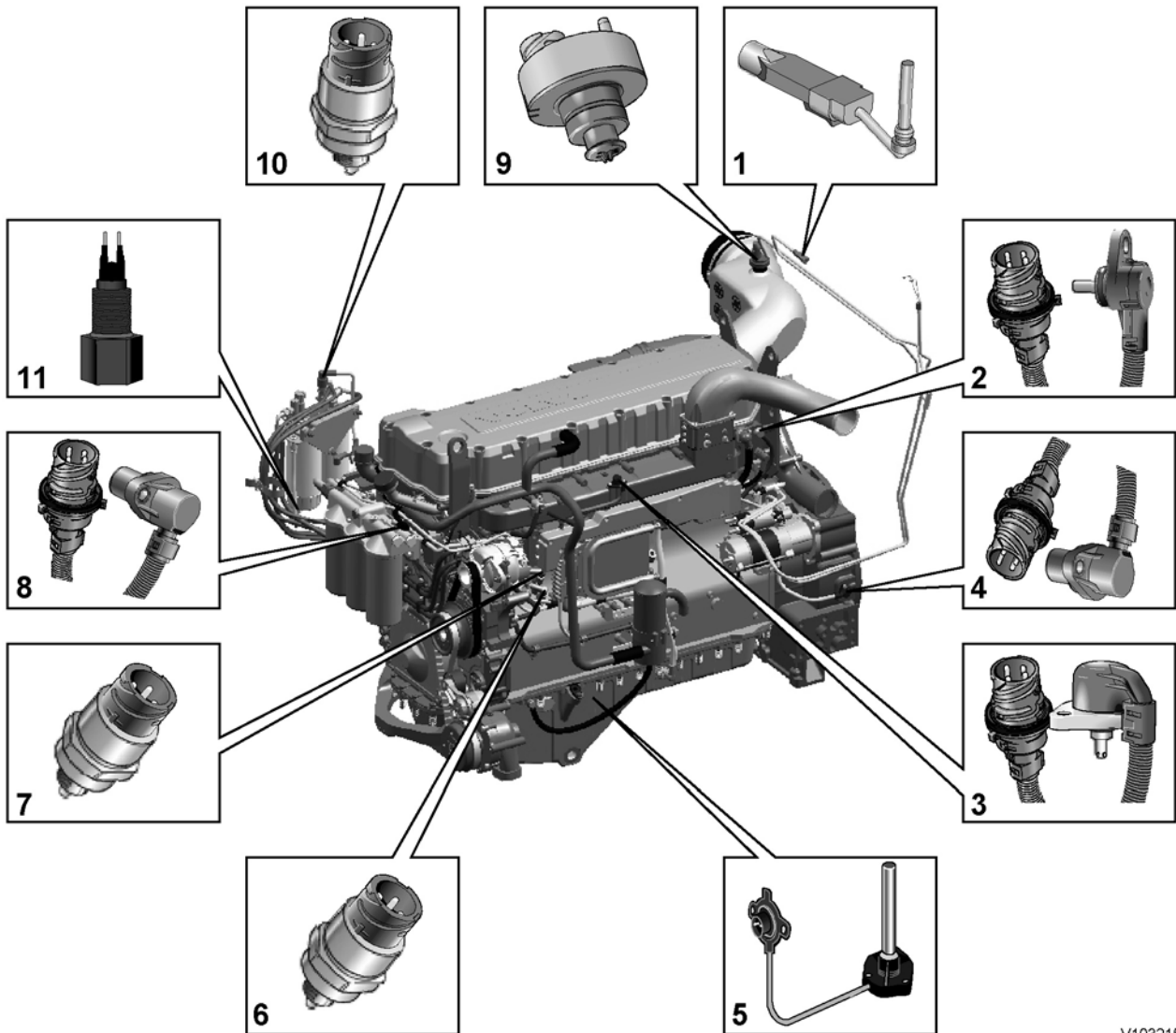

V1032159

Figure 2
D12D Engine sensors (some have dual functions)

1. Sensor for coolant level, SE2603
2. Sensor for coolant temperature, SE2606
3. Sensor for charge air pressure/temperature, SE2507/SE2508
4. Tachometer sensor, flywheel, SE2701
5. Sensor for oil level/temperature, SE2205/SE2202
6. Sensor for crankcase pressure, SE2509
7. Sensor for oil pressure, SE2203
8. Camshaft sensor, engine position, SE2703
9. Sensor for air pressure/temperature, SE2501/SE2502
10. Sensor for feed pressure, fuel, SE2301
11. Sensor for water indicator, SE2302

Document Title: E-ECU D12, Functions	Function Group: 200	Information Type: Service Information	Date: 2014/8/22
Profile: ART, A35D [GB]			

E-ECU D12, Functions

- Fuel amounts, unit injectors

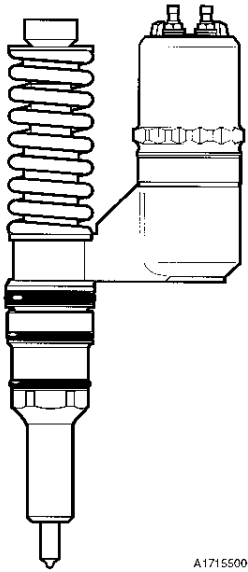

Figure 1
Unit injector "Bosch"

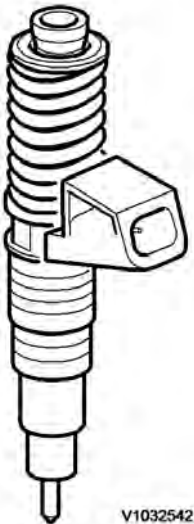

Figure 2
Unit injector "Delphi"

- Exhaust brake **Applies only to machine equipped with engine D12C**

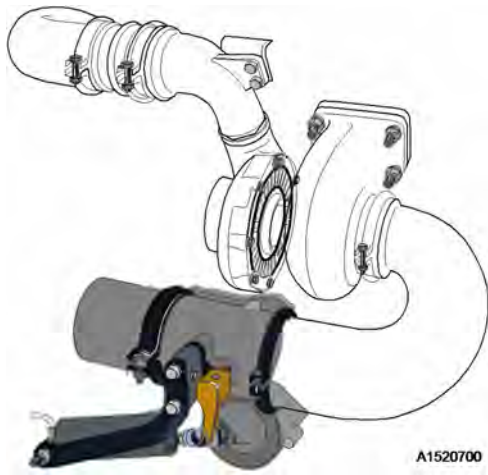

Figure 3
Exhaust brake

- Exhaust brake **Applies only to machine equipped with engine D12D**

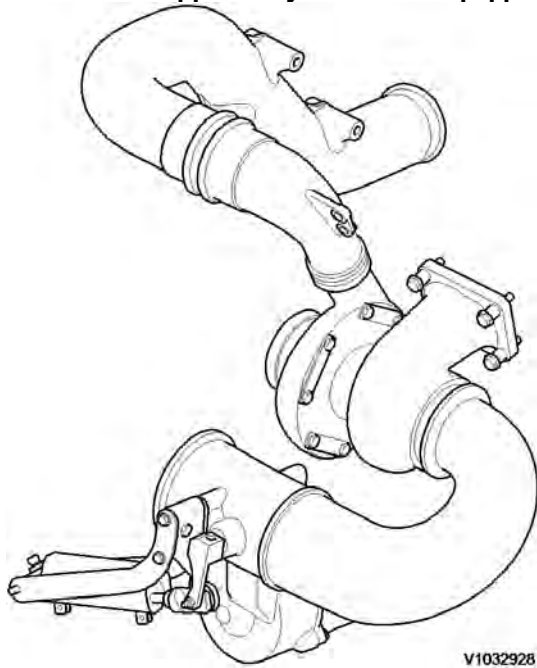

Figure 4
Exhaust brake

- Compression brake **Applies only to machine equipped with engine D12C**
MA2503

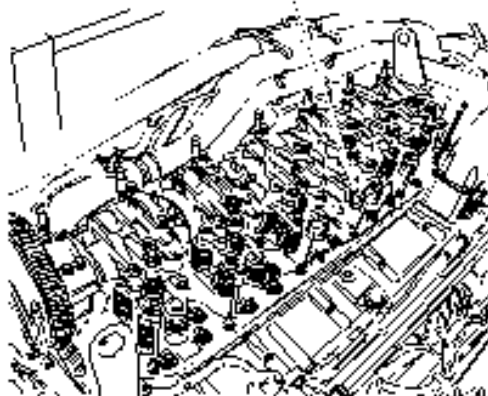

Figure 5
MA2503 (PPID 122), solenoid valve for compression brake

- Temperatures, pressures and rpms



Figure 6
SE2507 (PID 105)/SE2508 (PID 102) Charge air temperature/pressure

- Preheating element, preheating

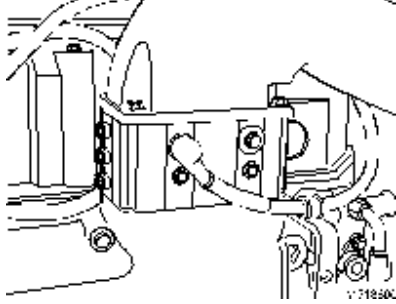

Figure 7
Preheating element

- Raised engine speed. The switch is connected to the cab control unit (C-ECU) which sends a message via the data bus to the engine control unit (E-ECU).

NOTE!

Raised engine speed is optional equipment.

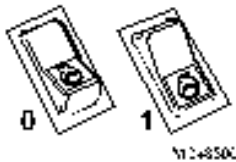
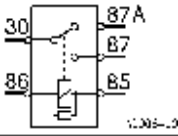

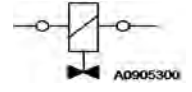
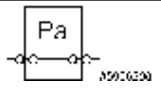
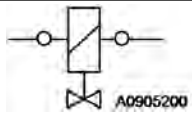
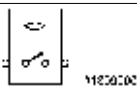
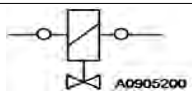
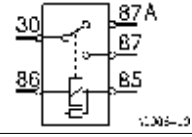
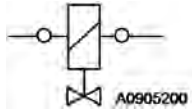

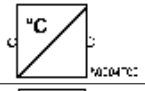

Figure 8
Switch, raised engine speed

Document Title: E-ECU D12D, Input and Output terminals	Function Group: 200	Information Type: Service Information	Date: 2014/8/22
Profile: ART, A35D [GB]			

E-ECU D12D, Input and Output terminals

INPUTS		ECU	OUTPUTS	
Digital				
	Detection of preheating (RE2501, pin 87)		Control, injectors 1-6, MA2301-2306	
	Monitor, air filter, pressure, SE2502		Control, pressure governor, exhaust brake (EPG1), PWM2501	
	Monitor, coolant level, SE2603		Control, pressure governor / shutter, exhaust brake (EPG2), MA2502	
			Preheating induction air, RE2501	
			Control, exhaust circulation, MA2504 [T1] ⓘ	

[T1] Only applies to A35D equipped with engine D12DAAE3 and A40D equipped with engine D12DABE3

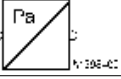
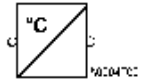
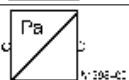
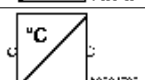
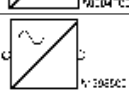
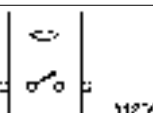
INPUTS		ECU
Analogue		
	Sensor, engine oil temperature, SE2202	
	Sensor, engine oil pressure, SE2203 Sensor, fuel pressure, SE2301	
	Sensor, ambient air, temperature, SE2501 Sensor, charge-air temperature, SE2507	
	Sensor, charge-air pressure, SE2508	
	Sensor, coolant temperature, engine, SE2606	
	Sensor, engine speed, SE2701 Sensor, camshaft speed, SE2703	
	Monitor, water in fuel, SE2302	

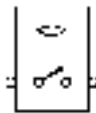
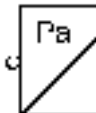
 <p>The symbol consists of a square frame containing a horizontal line with a small circle above it, and a diagonal line with a small circle at its end. Below the frame is the alphanumeric code '41230100'.</p>	Monitor, engine oil level, SE2205
 <p>The symbol consists of a square frame containing a diagonal line from the bottom-left to the top-right, with the letters 'Pa' in the upper-left corner. Below the frame is the alphanumeric code '41308400'.</p>	Sensor, crankcase pressure, SE2509

Document Title: Engine D12, description	Function Group: 200	Information Type: Service Information	Date: 2014/8/22
Profile: ART, A35D [GB]			

Engine D12, description

Engine D12, description

Engine D12 is available in two versions, D12C and D12D. See the product plate for the machine regarding which engine version applies to the machine.

Engine D12 is a straight, six-cylinder, direct injection, diesel engine with a cylinder capacity of 12 litres. It is equipped with a turbocharger and an intercooler and electronically controlled fuel injection, EMS (Engine Management System). It has an overhead camshaft and unit injectors instead of injection pump and injectors.

The unit injectors are positioned in the centre above the pistons and are controlled via the camshaft and a control unit (E-ECU).

The control unit is positioned on the left side of the cylinder block.

Engine D12C

Applies to machine equipped with engine D12C, with serial number according to the table.

Machine	Place of manufacture, serial number		
	BRA	ASH	PED
A35D	- 12999	- 61303	- 71999
A40D	- 11999	- 60286	

Engine D12D

Applies to machine equipped with engine D12D, with serial number according to the table.

Machine	Place of manufacture, serial number		
	BRA		PED
A35D	13001-		72001-
A40D	12001-		70001-

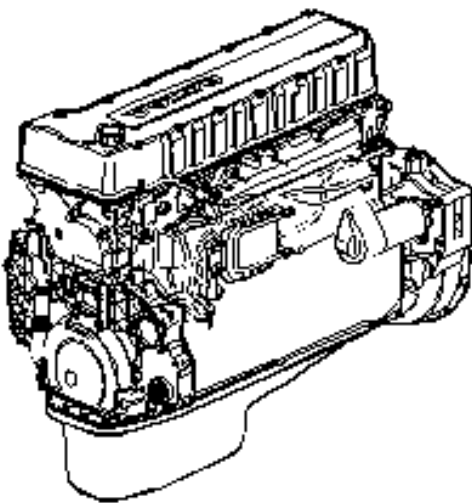

Figure 1

Document Title: Engine, identification	Function Group: 200	Information Type: Service Information	Date: 2014/8/22
Profile: ART, A35D [GB]			

Engine, identification

Identification plate 1

Engine designation, serial number, part number and assembly plant are stamped in one field on the engine block's left rear edge

Identification plate 2

A decal with the software's ID-number, the engine's serial number and assembly plant is located on the valve cover to ensure installation of correct ECU on the engine in production. On the back of the ECU, there is a decal indicating its hardware number.

Assembly plants:

A = Skövde, Sweden

E = Curitiba, Brazil

F = Flen, Sweden

L = Lyon, France

Identification plate 3

The certification decal is located on the valve cover as well as on the left side of the machine's front frame.

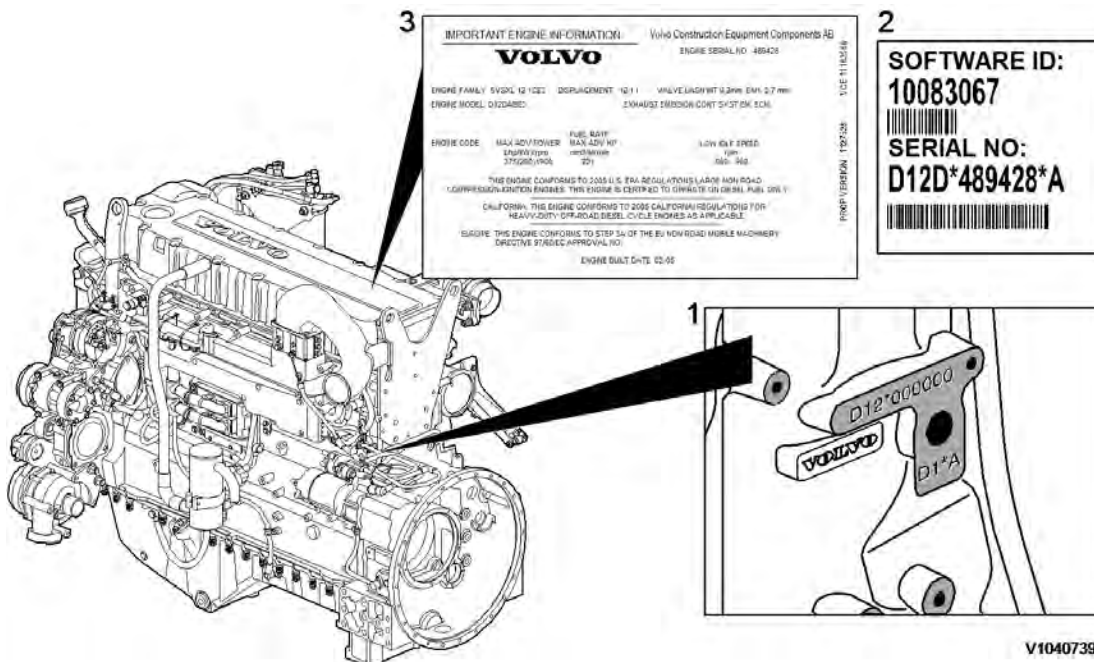

Figure 1
Engine identification, D12D



V1063847

Figure 2
Certification decal

Document Title: Compression test	Function Group: 210	Information Type: Service Information	Date: 2014/8/22
Profile: ART, A35D [GB]			

Compression test

Op nbr 210-002

[9990185 Lifting tool](#)

[9998248 Adapter](#)

[88880003 Bracket](#)

[9998248 Adapter](#)

[9998248 Adapter](#)

[9998248 Adapter](#)

[9998248 Adapter](#)

[9998248 Adapter](#)

[9998665 Adapter](#)

[9988539 Pressure gauge](#)

[9990006 Puller](#)

[9990262 Adapter](#)

[9996400 Impact puller](#)

[9998599 Cleaning tool](#)

[88820003 Setting tool](#)

[9993590 Gear wheel](#)

This operation also includes the tools and times needed for required parts of the following actions:

- [214 Valves, adjusting](#)
- [233 Fuel system, bleeding](#)

Dismantling

1. Place the machine in service position.
2. Pump up the engine hood.
3. Drain the cylinder head to avoid fuel in the engine oil. Loosen and plug the hose connection in the engine's trailing edge. Loosen the feed hose and lead it into a container. Since the feed pump will pump out fuel during the test, the container's volume must be at least **5 litres (1.3 US gal)**.

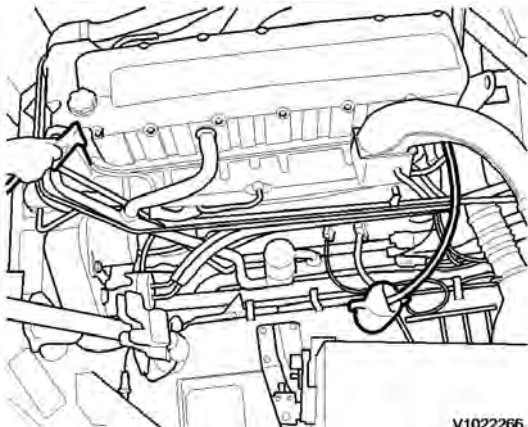

V1022266

Figure 1

V1022266

4. Open the bleeder nipple on the cylinder head's leading edge and use an air nozzle in the fuel's inlet channel to lead out the fuel.

NOTE!

Collect the excess fuel in a container.

5. Remove the hose from the oil trap and remove the valve cover.

NOTE!

Do not use a nut runner since the studs bolts may come loose from the cylinder head and damage electrical cables and valve cover.

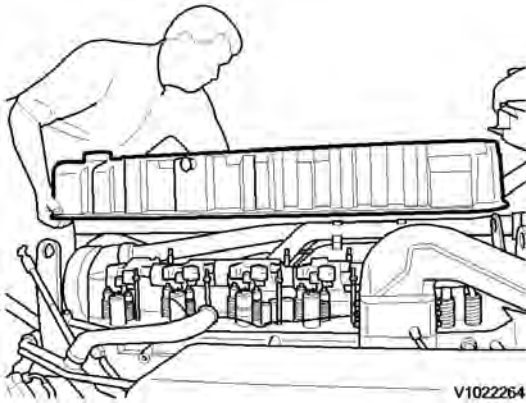

Figure 2
V1022264

6. Remove the unit injectors' electrical connections.
7. Remove the IEGR control valve's electrical connections and wipe clean around the control valve.
8. Remove the valve cover's stud bolt located in front of the IEGR control valve.

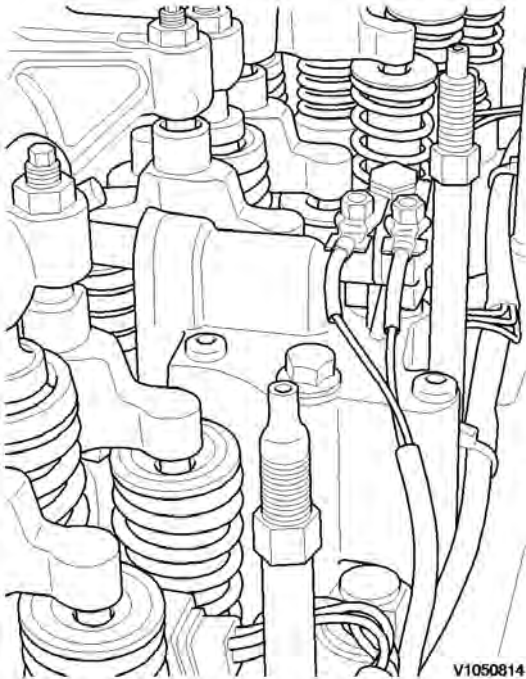

Figure 3

Stud bolt

9. Remove the bolts for the IEGR control valve. Remove the control valve and the pipe between the valve and the

rocker arm shaft.

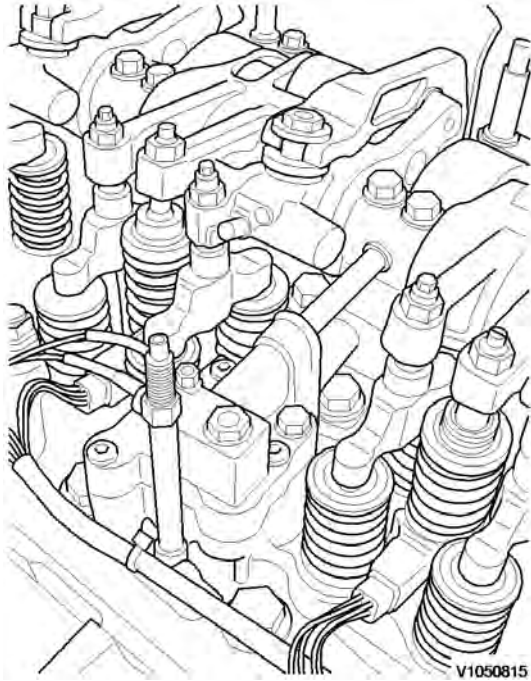

Figure 4
V1050815

10. Loosen the bolts for the rocker arm bridge equally in sequences, so that the rocker arm shaft is not bent. Remove the bolts and carefully lift away the rocker arm bridge with 9990185 and 88880003.

NOTE!

For engines with VEB: fixate the pistons in the rocker arms with rubber bands or similar so that the pistons do not fall out.

NOTE!

Pistons and rocker arms are classed as units. Marking (one, two, or three dots) must match.

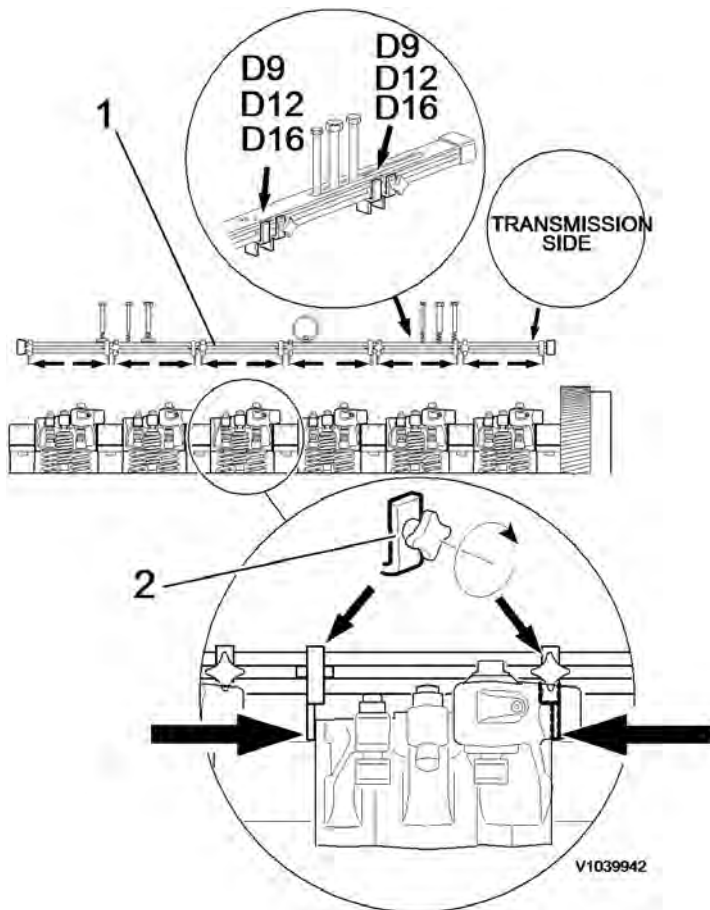

Figure 5

11. **NOTE!**

Clean very thoroughly around the unit injectors.

Remove the bolts for the unit injectors' attaching yoke. Remove the unit injector with 9996400 Impact puller9990262 Adapter9990006 Puller.

NOTE!

Place each injector in separate new plastic bags. Mark which cylinder they were installed in. It is important to not mix up the injectors since they are classed for a certain cylinder.

Buy Now



Our support email:

ebooklibonline@outlook.com