

| | | | |
|---|-------------------------------|---|---------------------------|
| Document Title: Engine, description | Function Group: 200 | Information Type: Service Information | Date: 2014/3/14 |
| Profile: BHL, BL61B [GB] | | | |

Engine, description

The engine is a four-cylinder, four-stroke, in-line diesel engine with direct injection, exhaust turbocharger, liquid cooling and internal, unregulated exhaust gas recirculation (EGR).

To comply with exhaust gas limit values, the turbocharger is equipped with **unregulated, internal exhaust gas recirculation (IEGR)**, which returns the exhaust gas within the cylinder head to the combustion air. The oxygen content of this exhaust is low. A lower oxygen content reduces the temperature spike during combustion and thereby reduces nitrogen oxide (NO_x).

The camshaft has an extra cam - the trailing cam. This causes the inlet valve to briefly open during the exhaust stroke so that exhaust gas also enters the engine intake system. In the subsequent induction stroke, this exhaust is sucked back in. There is no regulation of exhaust gas quantity.

Engine data plate

The engine data plate specifies model, engine number and power data. The engine number is also stamped into the crankcase. Model and engine number must be specified when ordering spare parts. The direction of rotation is found on the flywheel, anticlockwise. Firing order: 1-3-4-2 (cylinder no. 1 on the flywheel side).

IMPORTANT! Adjustments to the regulator may only be performed by trained staff in an authorized central repair workshop.

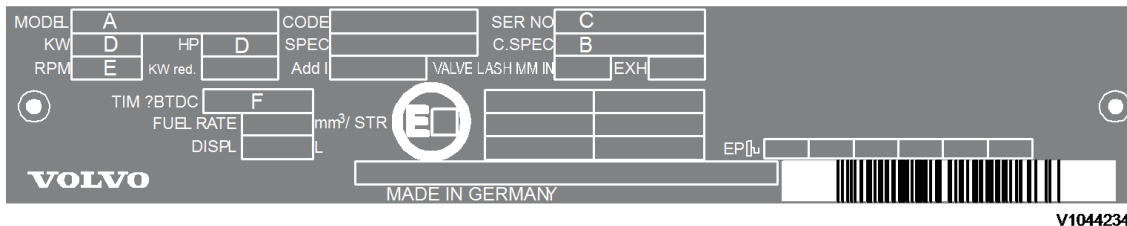

V1044234

Figure 1
Engine data plate

- A. Engine type
- B. Spare part number
- C. Engine number
- D. Capacity
- E. Rated speed
- F. Timing setting

Components, servicing view

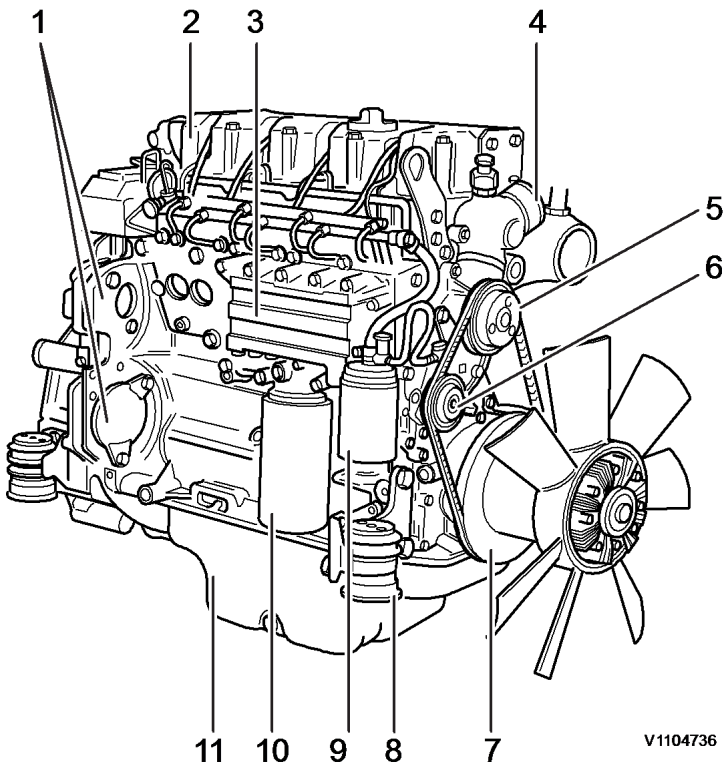

V1104736

Figure 2
Components, servicing view

1. Attachment for power take-off
2. Cylinder head
3. Oil cooler
4. Coolant supply
5. Coolant pump
6. Fuel pump
7. Vibration damper
8. Engine mounting
9. Oil filter
10. Fuel filter
11. Oil sump

Components, exhaust view

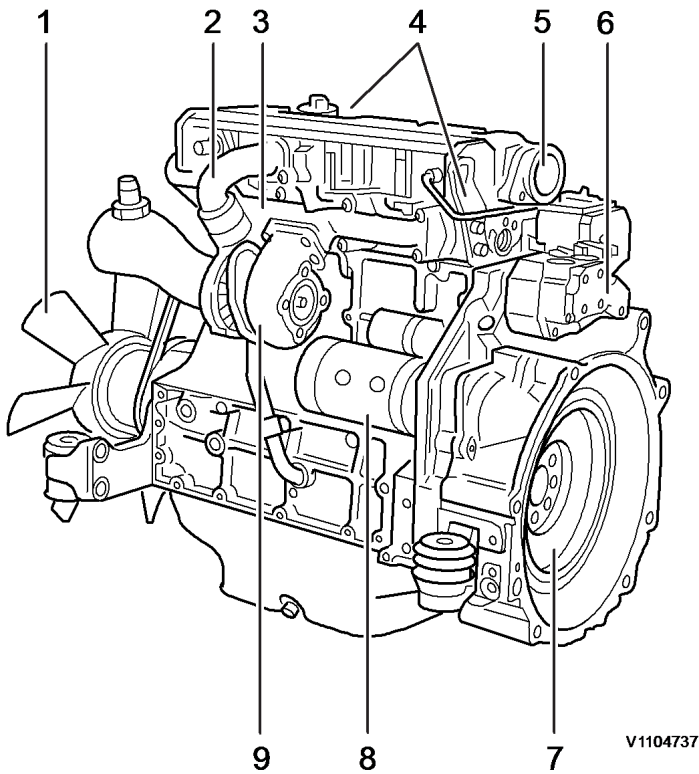

Figure 3
Components, exhaust view

1. Engine fan
2. Inlet manifold
3. Exhaust manifold
4. Transport device
5. Crankcase ventilation
6. Speed (rpm) sensor
7. Flywheel
8. Starter motor
9. Turbocharger

| | | | |
|--|-------------------------------|---|---------------------------|
| Document Title: Engine, removing | Function Group: 210 | Information Type: Service Information | Date: 2014/3/14 |
| Profile: BHL, BL61B [GB] | | | |

Engine, removing

Op nbr 210-070

[885530 Rotation tool](#)

Lifting chains, min. 1000 kg (2200 lb)
two chain tensions



Hot liquids and machine parts can cause burns. Allow the machine to cool before beginning any work.

NOTICE

Always handle oils and other environmentally hazardous fluids in an environmentally safe manner.

NOTE!

In general, all cable ties that secure hoses and electrical cables must be removed. All disconnected hoses and open connections must be plugged.

1. Place the machine in Service position 1, see [191 Service position 1](#).
2. Disconnect the main battery switch.
3. Remove the battery/batteries, see [311 Batteries, replacing](#).
4. Drain the coolant, see [173 Coolant, change](#).
5. Drain the transmission oil, see [173 Transmission, changing oil](#).
6. Disassemble the engine hood, see [821 Engine hood, removal](#).
7. Loosen the retaining clamp of the exhaust pipe (2). Remove the exhaust pipe together with it's sealing.

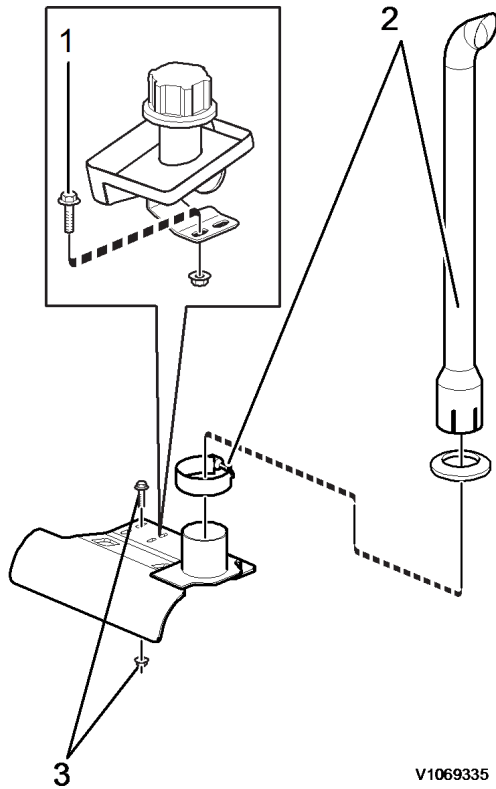

Figure 1
exhaust assembly, disassembly

1. retaining screws filler neck assembly
2. exhaust pipe with retaining clamp
3. retaining screws exhaust assembly bracket

8. Loosen and remove the retaining screws (1) of the oil filler neck assembly.
9. Loosen the retaining screws and disconnect the flexible exhaust tube from the turbocharger.



10.

WARNING

The parts are heavy. Take appropriate safety cautions when handling them.

Use a slop to attach the exhaust assembly to a suitable lifting device.

11. Loosen and remove the retaining screws (3) of the exhaust assembly bracket.
12. Remove the exhaust assembly from the machine.
13. Loosen the retaining clamps (4, 5) from the upper radiator hose (1) and remove the hose.

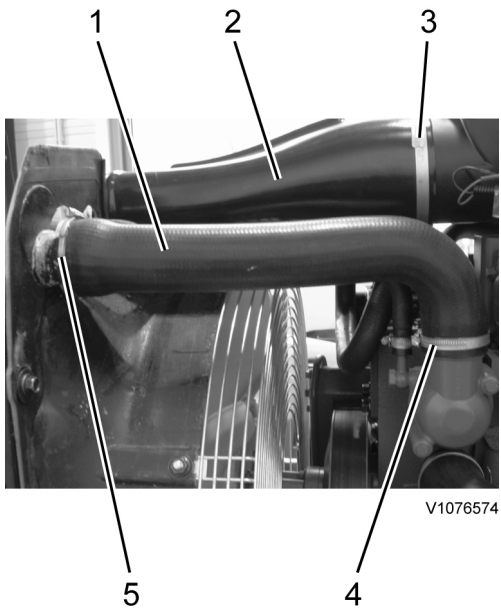

Figure 2
radiator hose and air inlet, disassembly

- 1. upper radiator hose
- 2. air inlet
- 3. retaining clamp
- 4. retaining clamp
- 5. retaining clamp

- 14. Loosen the retaining clamp (3) from the air inlet (2) and remove it from the air filter assembly.
- 15. Loosen and remove the hoses (4, 5) connecting the expansion tank (3) with the coolant pump (6).

NOTE!

Loosen the retaining clamps on the pump side, so the hoses can be removed with the tank.

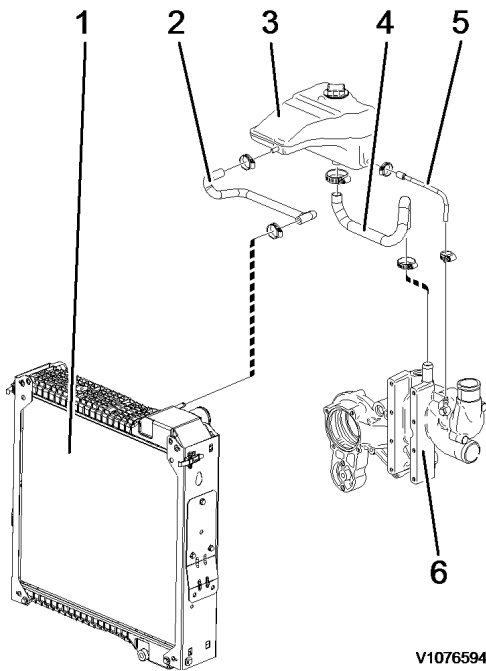

Figure 3
radiator with attached parts

- 1. radiator
- 2. hose

- 3. expansion tank
- 4. hose
- 5. hose
- 6. coolant pump

16. Loosen and remove the hose (2) connecting the expansion tank (3) to the radiator (1).

NOTE!

Loosen the retaining clamp on the radiator side, so the hose can be removed with the tank.

17. Loosen the retaining screws connecting the expansion tank's attachment bracket to the machine frame.

18. Remove the expansion tank with the attachment bracket.

19. Disconnect the two pressure sensor connectors from the air filter (2).

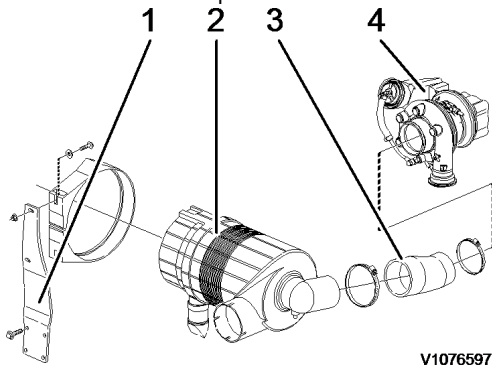

V1076597

Figure 4
air filter, disassembly

- 1. attachment bracket
- 2. air filter
- 3. hose
- 4. turbocharger

20. Loosen the retaining clamp connecting the air filter hose (3) to the turbocharger (4).

21. Remove the hose from the turbocharger.

22. Loosen and remove the retaining screws connecting the air filter to the engine (4 pcs).

23. Remove the complete air filter assembly.

24. Loosen and remove the retaining screws of the fan guard.

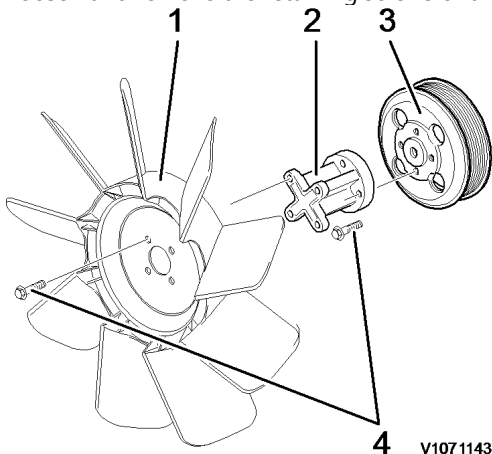

V1071143

Figure 5
fan, disassembly

1. fan
2. fan adapter
3. V-belt pulley
4. retaining screws

25. Remove the fan guard.

26. Loosen and remove the retaining screws (4) of the fan (1).

27. Slightly turn the fan, to remove it from the fan adapter (2).

NOTE!

Leave the fan inside the fan shroud.

28. Loosen and remove the retaining screws (4) together with the fan adapter.

29. Loosen and remove the retaining screws of the fan shroud.

30. Remove the fan shroud together with the fan.

31. Disassemble the transmission oil filler pipe from the engine.

32. Remove the coolant pump (1) connection of the lower coolant hose (2).

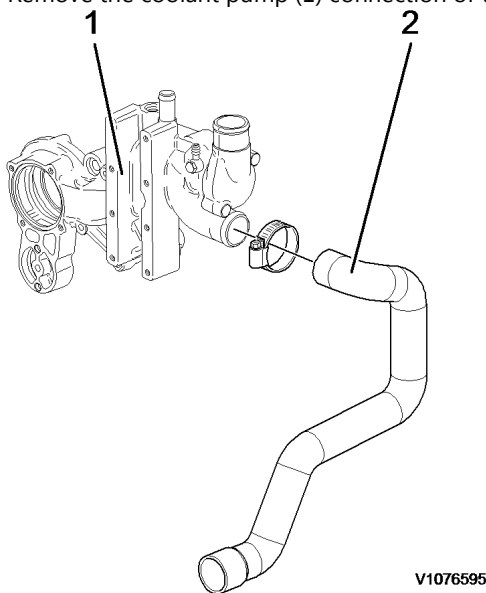

Figure 6
coolant hose, disassembly

1. coolant pump
2. lower coolant hose

33. Remove the two battery connection cables from the starter motor.

34. Remove all electrical connectors and cables from the engine. Make notes to which component the connectors and cables have to be attached.

35. Loosen the hose (1) from the engine oil cooler.

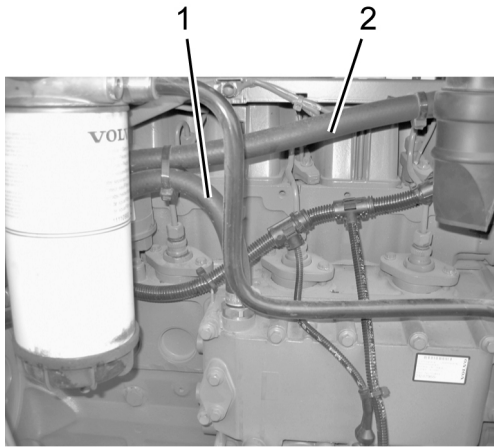

V1076593

Figure 7
hoses, disassembly

1. hose to engine oil cooler
2. hose to coolant pump

36. Loosen the hose (2) from the coolant pump.
37. Loosen and remove the hose (1) from the main fuel filter (3).

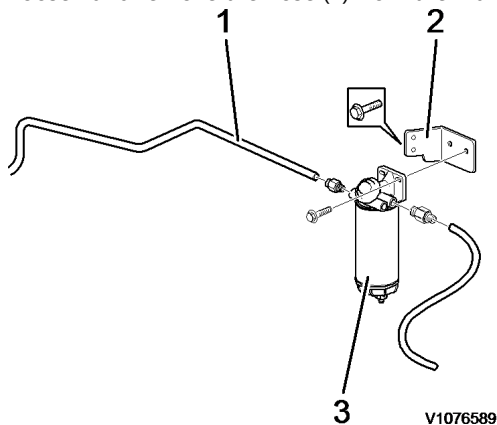

V1076589

Figure 8
main fuel filter, disassembly

1. hose (tank connection)
2. attachment bracket
3. fuel filter

38. Loosen and remove the fuel filter from the attachment bracket (2). Fasten the filter to the engine (cable tie).
39. Loosen and remove the filter's attachment bracket from the machine.
40. Loosen the adjusting nuts (1) of the throttle cable.

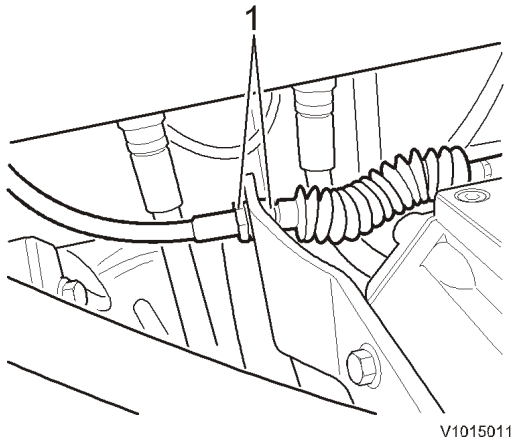

V1015011

Figure 9
throttle cable, disassembly

1. adjusting nuts

41. Loosen and remove the retaining nut. Remove the throttle cable from the lever (1).

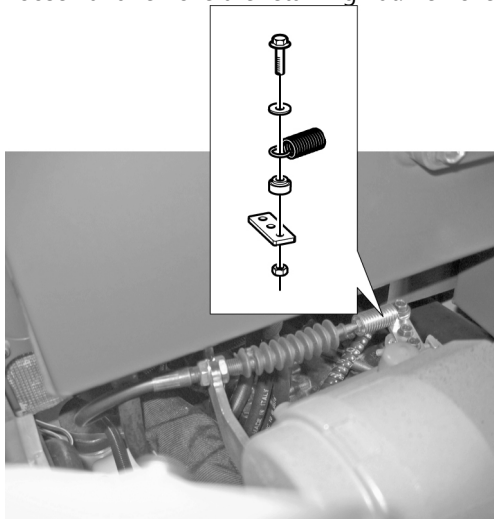

V1078245

Figure 10
throttle cable, disassembly

1. accelerator lever

42. Secure all disconnected hoses and cables, so they can't be caught when removing the engine.
43. Remove the plate on the engine to access the screws connecting engine to turbocharger.

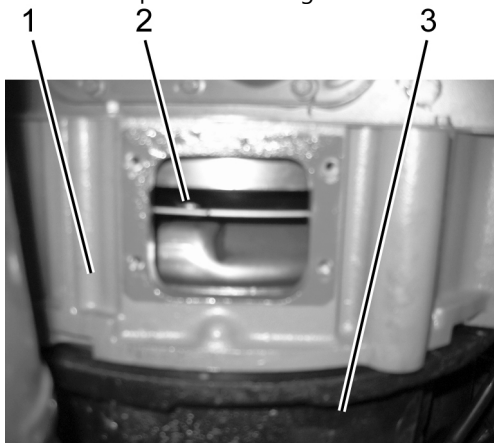

V1078423

Figure 11
engine, retaining screws torque converter

1. engine
2. retaining screws, torque converter
3. transmission

44. Loosen the connection screws from engine to torque converter (4 pcs). To turn the engine and screws in the right position, use special tool.

Special tool:
885530 Rotation tool



45. **The parts are heavy. Take appropriate safety precautions.**

Place a suitable support under transmission and hydraulic pump to avoid overturning when engine is disconnected.

46. Attach the engine with a suitable chain and two chain tensions to a crane. The chain tensions are used to align the engine while removing from machine.



V1076510

1

Figure 12
engine, attached to lifting device

1. Additional lifting eye must be attached for the 2nd chain tension

Engine weight (dry):

520 kg (1146.2 lb)

47. Loosen the connection screws from engine to transmission.

48. Loosen the connection screws from the engine to the engine mounts (3) (on the left and right of the machine front).

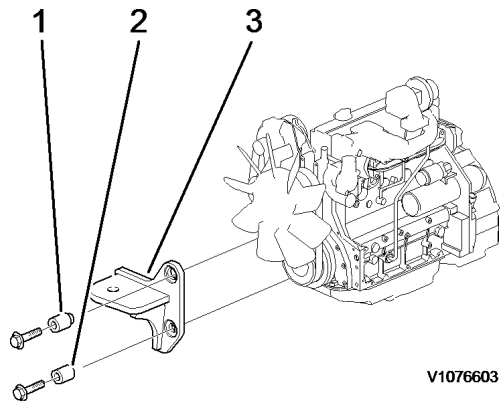

Figure 13
engine mounts, disassembly

1. spacer
2. spacer
3. engine mounting

49. Disassemble the engine mounts from the frame.

NOTE!

Take care not to loose the spacers.



WARNING

50.

Risk of crushing injuries

Use the crane and the chain tensions to remove the engine from the transmission shaft.



WARNING

51.

Heavy lift. Make sure that everybody stands well back from the engine when it is lifted.

Carefully lift the engine out of the machine and place the engine on suitable stable surface.

NOTE!

Take care not to catch any hoses or cables when removing.

| | | | |
|--|-------------------------------|---|---------------------------|
| Document Title: Engine, installing | Function Group: 210 | Information Type: Service Information | Date: 2014/3/14 |
| Profile: BHL, BL61B [GB] | | | |

Engine, installing

Op nbr 210-072

[885530 Rotation tool](#)

Lifting chains, min. 1000 kg (2200 lb)
two chain tensions

NOTICE

Always handle oils and other environmentally hazardous fluids in an environmentally safe manner.

NOTE!

In general, all cable ties that have been removed must be replaced. Hoses and cables must be fastened, so that they cannot move.

1. **WARNING**

The parts are heavy. Take appropriate safety precautions.

Attach the engine with a suitable chain and two chain tensions to a crane. The chain tensions are needed to align the engine while installing to machine.

Engine weight (dry):

520 kg (1146.2 lb)



V1076510

Figure 1
engine, attached to lifting device

1. Additional lifting eye must be attached for the 2nd chain tension
2. Assemble the left engine mount (3) to the engine.

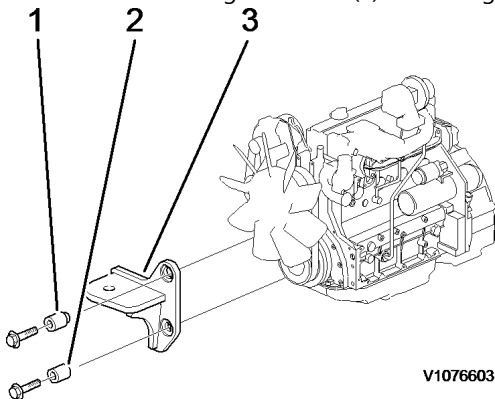

Figure 2
engine mounts, assembly

1. spacer
2. spacer
3. engine mounting

3. **WARNING**
Heavy lift. Make sure that everybody stands well back from the engine when it is lifted.

Carefully lift the engine in the machine.

NOTE!

Take care not to crush any hoses or cables when installing.

4. **WARNING**
Risk of crushing injuries

Use the crane and the chain tensions to assemble the engine to the transmission shaft.

NOTE!

Take care not to crush any hoses or cables when installing.

5. Assemble the engine with two screws to the transmission.
NOTE!
Don't fasten the screws completely. The engine must be free for aligning it to other parts.

6. Assemble the right side engine mount to the engine.

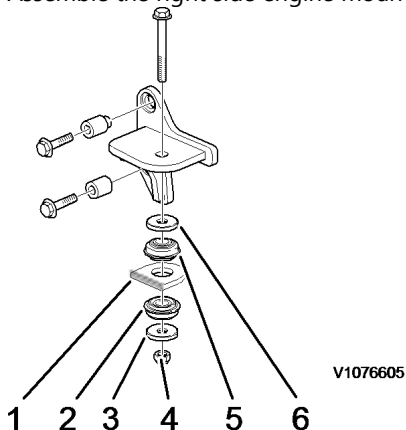

Buy Now



Our support email:

ebooklibonline@outlook.com