

Document Title: Engine, description	Function Group: 200	Information Type: Service Information	Date: 2014/3/18
Profile: BHL, BL71 PLUS [GB]			

[Go back to Index Page](#)

Engine, description

Numbering of cylinders

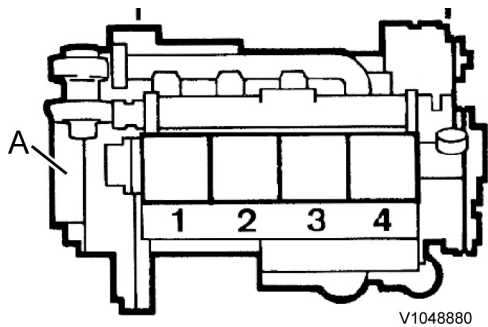

Figure 1

A = flywheel

Starter motor side

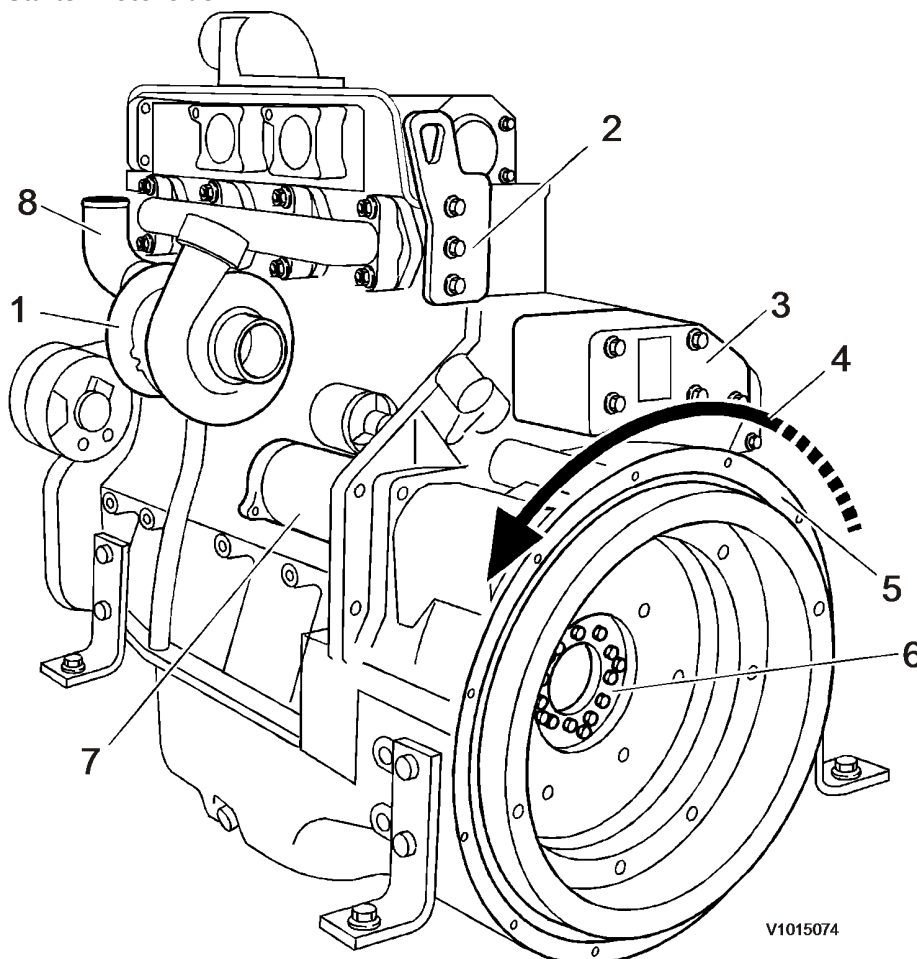

Figure 2

1. Turbocharger
2. Lifting eye
3. Engine revolution governor
4. Direction of rotation
5. Flywheel housing
6. Flywheel
7. Starter motor
8. Outlet pipe, coolant

NOTICE

The governor's settings may only be adjusted by trained personnel at a central overhaul workshop.

Engine revolution governor (Heinzmann).

The engine revolution governor on the D4D engine is of the centrifugal type.

Engine type, serial number and rated speed (rpm) must always be stated when ordering a governor as spare part.

Each regulator for the above mentioned engines has been especially made for a particular engine. This means that a governor cannot be moved from one engine to another.

NOTE!

An incorrectly adjusted governor may cause the engine not to meet the applicable regulations for emissions and performance.

Service side

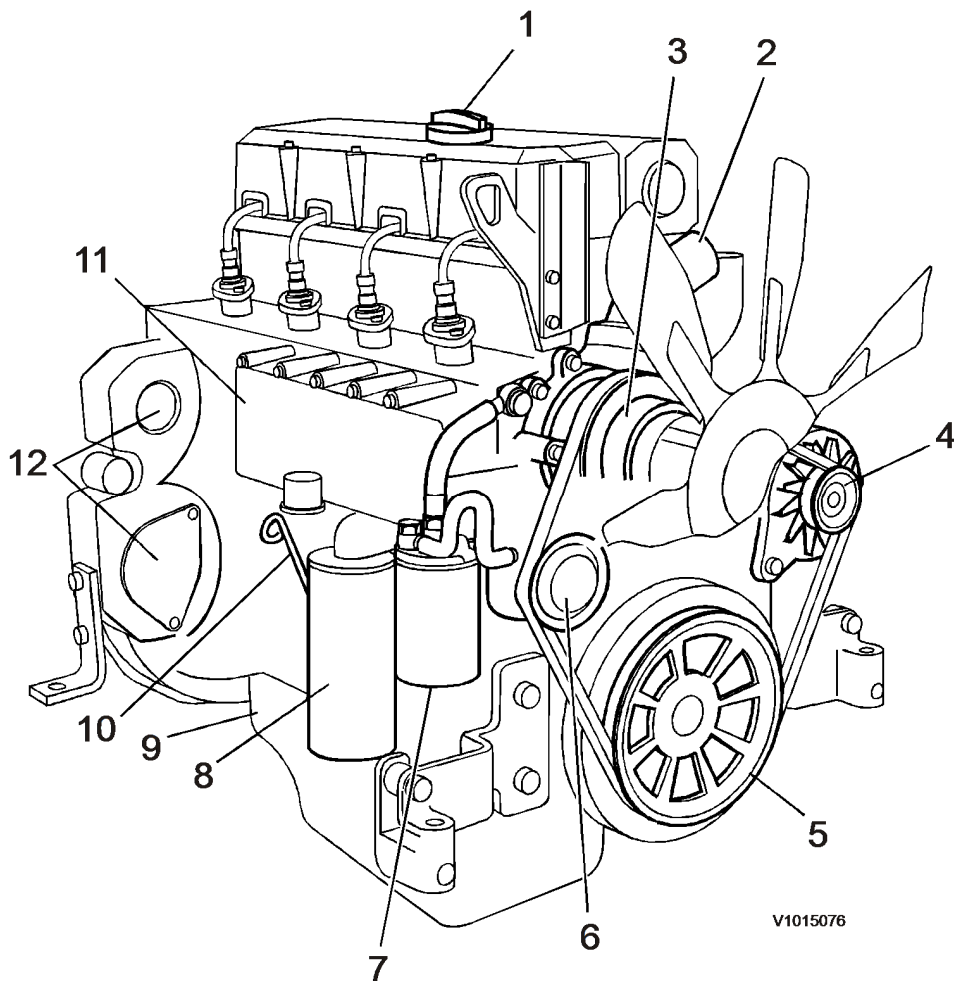

Figure 3

1. Oil filling point
2. Inlet pipe, coolant
3. Coolant pump
4. Alternator
5. Crankshaft belt pulley
6. Fuel pump
7. Fuel filter
8. Lubricating oil filter
9. Oil pan
10. Oil dipstick
11. Lubricating oil cooler
12. Power take-off for, for example, hydraulic pump, air compressor etc.
13. Cylinder head

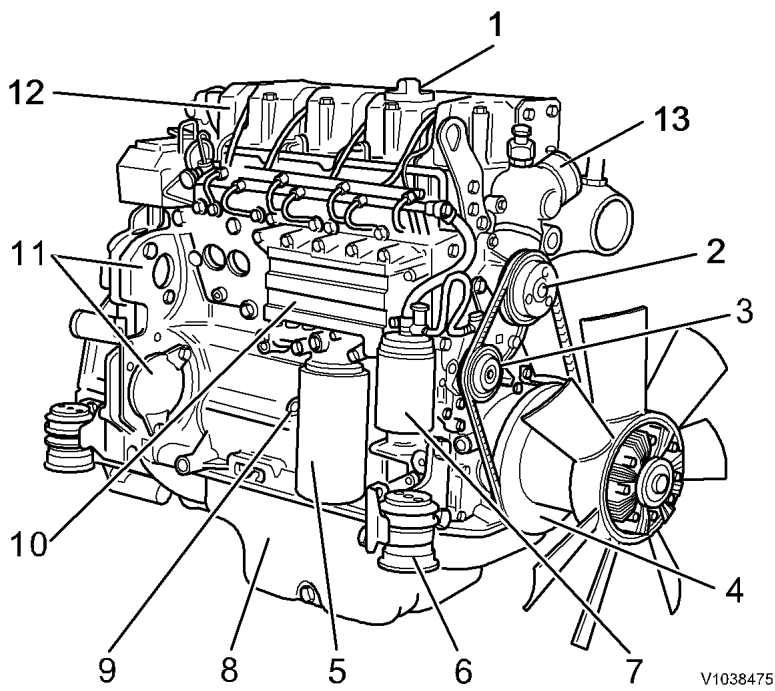
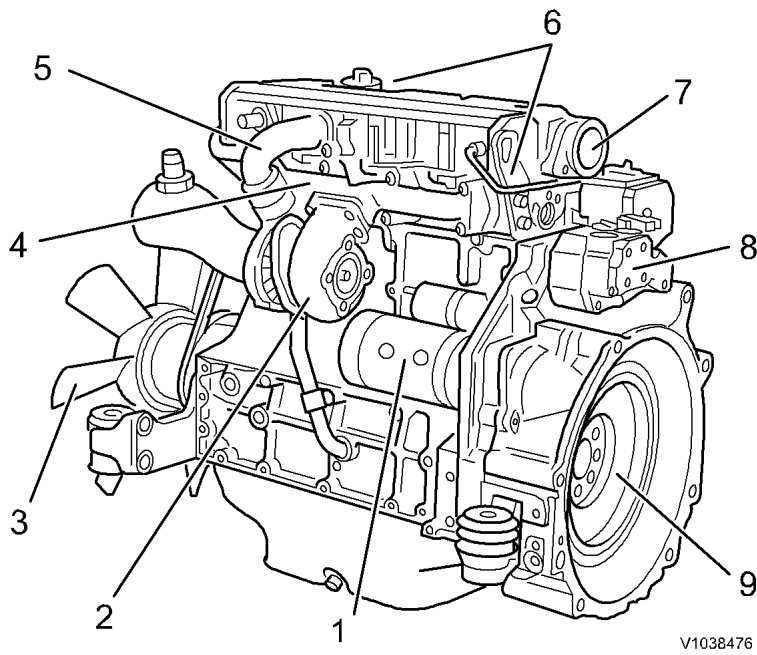

Figure 2
Components, servicing view

1. Oil filler pipe
2. Coolant pump
3. Fuel pump
4. Vibration damper
5. Oil filter
6. Engine mounting
7. Fuel filter
8. Oil sump
9. Oil dipstick
10. Oil cooler
11. Attachment for power take-off
12. Cylinder head
13. Coolant supply

Components, exhaust view



V1038476

Figure 3
Components, exhaust view

1. Starter motor
2. Turbocharger
3. Engine fan
4. Exhaust manifold
5. Inlet manifold
6. Transport device
7. Crankcase ventilation
8. Speed (rpm) sensor.
9. Flywheel

Document Title: Engine, removal	Function Group: 210	Information Type: Service Information	Date: 2014/3/18
Profile: BHL, BL71 PLUS [GB]			

[Go back to Index Page](#)

Engine, removal

Op nbr 21070-1

[14360000 Vacuum pump](#)

[Lifting chains, min. 1000 kg \(2200 lb\)](#)

WARNING

To avoid severe burns, **DO NOT** attempt the next procedure when the engine is **HOT**. Wait for the engine, silencer and tailpipe to cool before proceeding.

NOTE!

In general, all strip clamps that secure hoses and electrical cables must be removed. All disconnected hoses and open connections must be plugged.

1. Remove the engine hood, see [821 Engine hood, removal](#).
2. Detach cable from the bracket.

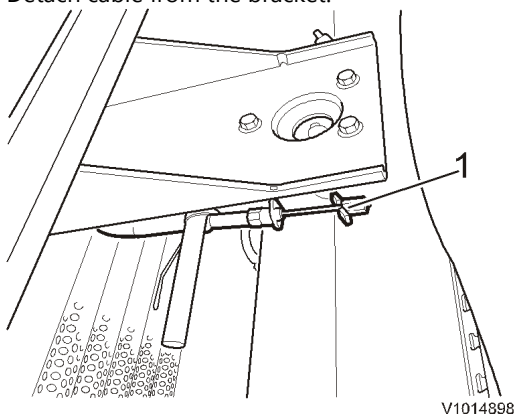

Figure 1

1. Cable
3. Remove the grille and the front plate.

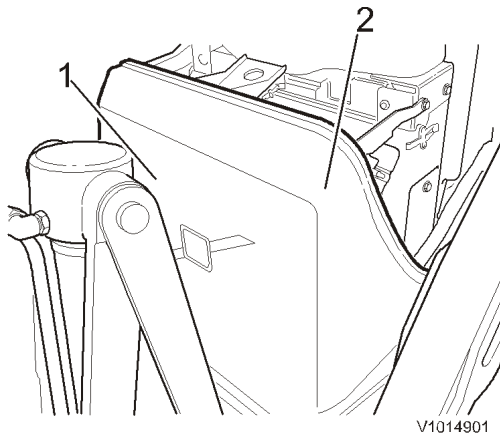

Figure 2

1. Grille
2. Front plate

4. Remove the clamps from both sides of the cooler.

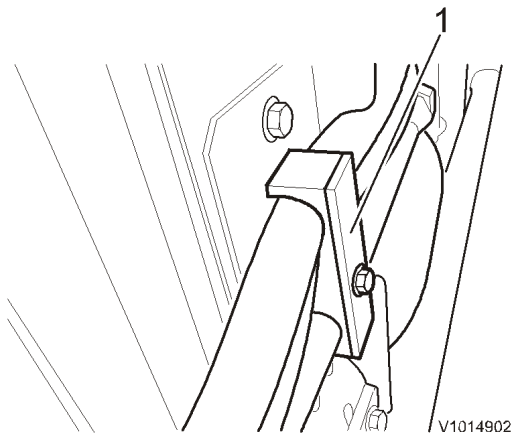

Figure 3

1. Clamp

5. Connect the vacuum pump, see [900 Vacuum pump connection](#).
6. Open the locking device and let down the hydraulic oil cooler. Disconnect the hoses (4 hoses) from the hydraulic oil cooler. Turn off the vacuum pump after the hoses have been plugged.

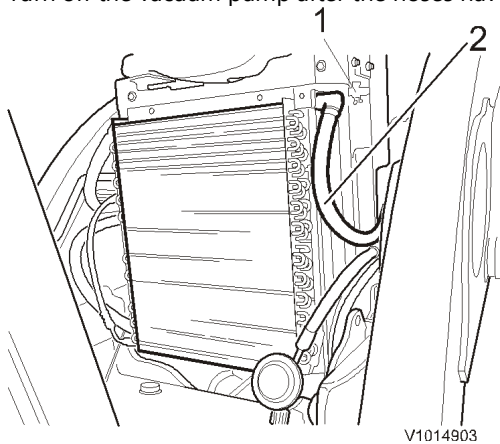

Figure 4

1. Locking device
2. Hoses

7. Connect a drain hose to the valve and place the drain hose down into a container. Open the valve and drain the coolant into the container.

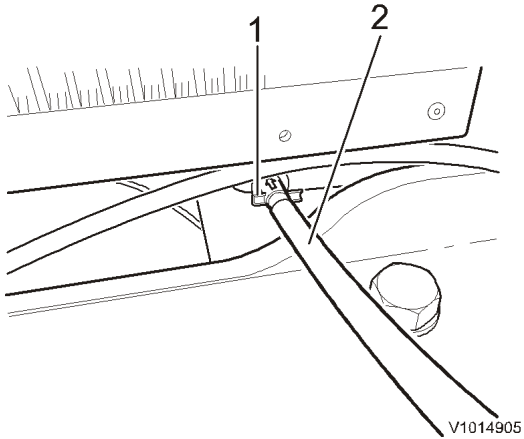

Figure 5

1. Valve
2. Drain hose

8. Disconnect the radiator hoses and the lower hose (hidden). Remove the screws radiator-radiator casting.

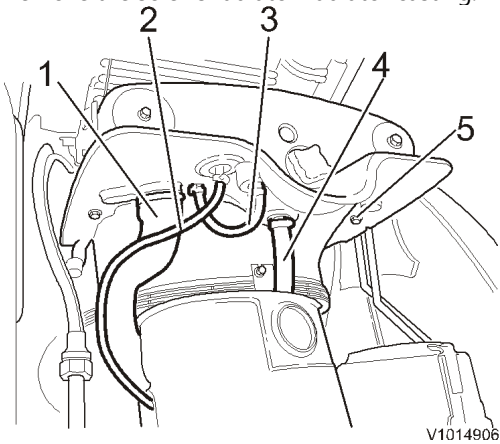

Figure 6

1. Hose
2. Hose
3. Hose
4. Hose
5. Screws

9. Remove the screws from both sides and lift out the hydraulic oil cooler and the radiator.

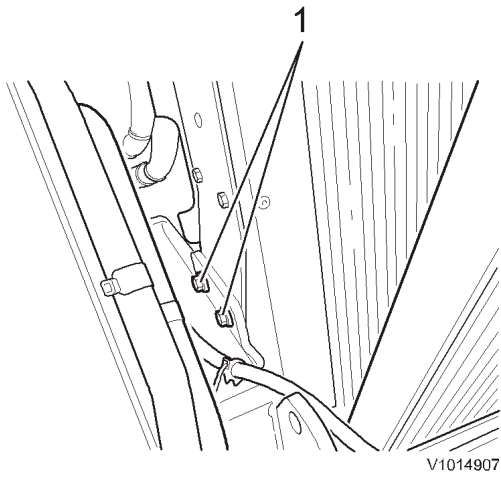

Figure 7

1. Screw

10. Remove the fan guard and the radiator casting.

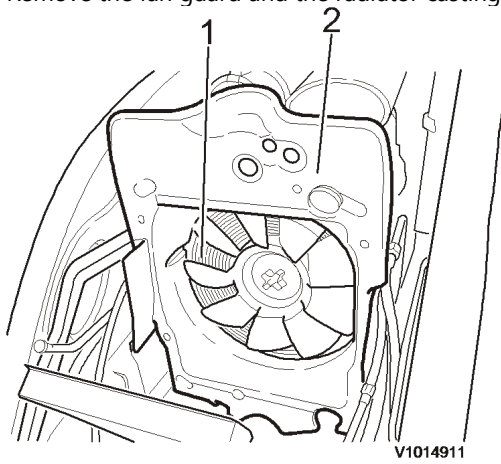

Figure 8

1. Fan guard

2. Radiator casting

11. Remove the fan.

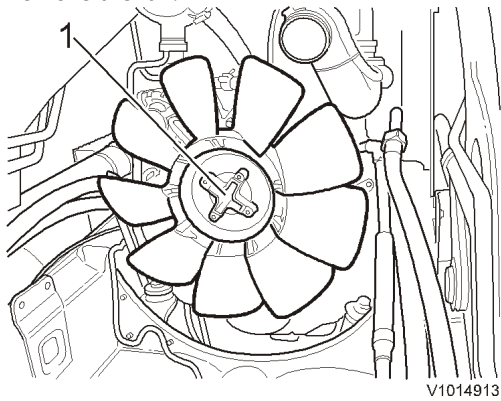

Figure 9

1. Fan

12. Remove the attaching screws (4 attaching screws, 2 underneath).
Remove the nuts and remove the silencer.

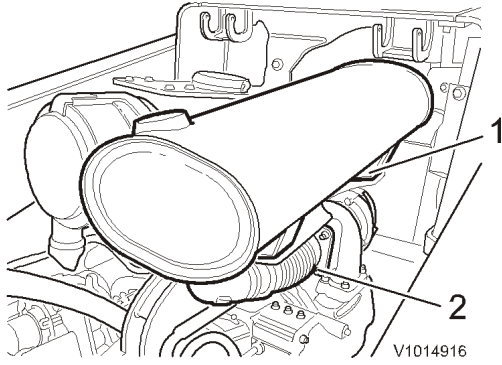

Figure 10

1. Attaching screws
2. Nuts

13. Loosen the hose clamp. Remove the screws and remove the air cleaner. Remove the screws (3 pcs) and remove the bracket.

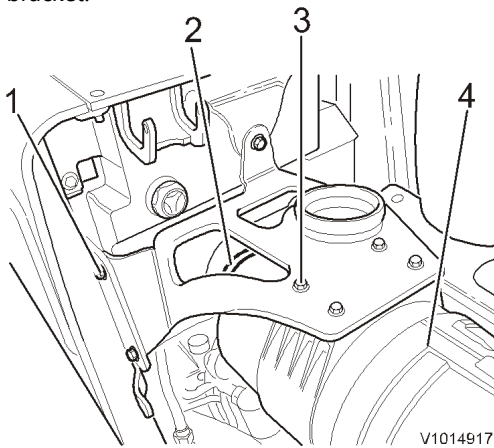

Figure 11

1. Screws
2. Hose clamp
3. Screws
4. Air cleaner

14. Disconnect hose from the engine.

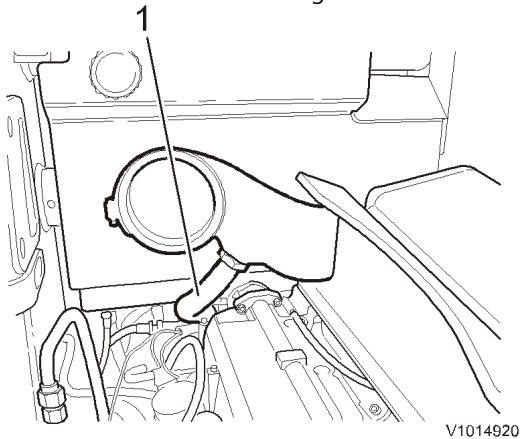

Figure 12

1. Hose

15. Disconnect the hoses (2 hoses, one hidden) from the engine and release the fuel filter/pump from the hydraulic tank.

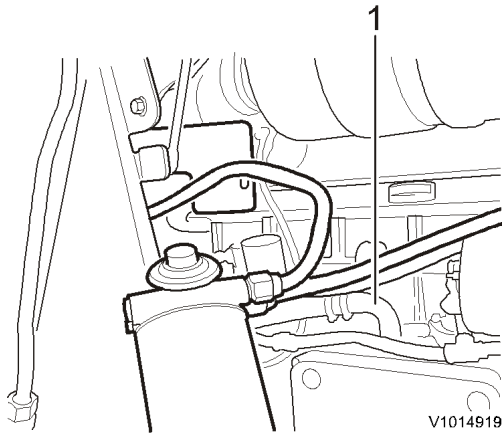

Figure 13

1. Hoses

16. Detach the seat, move the seat back, and lift up the rubber mat from the floor against the seat.

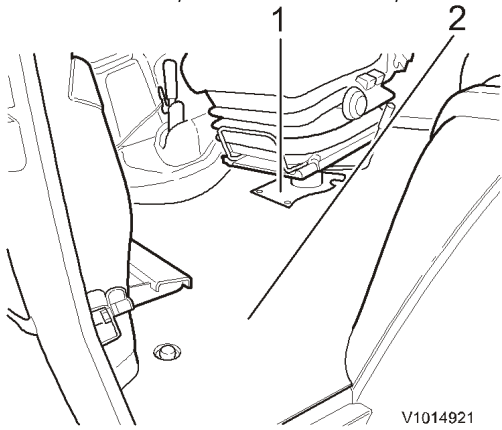

Figure 14

1. Seat
2. Rubber mat

17. Remove the plate.

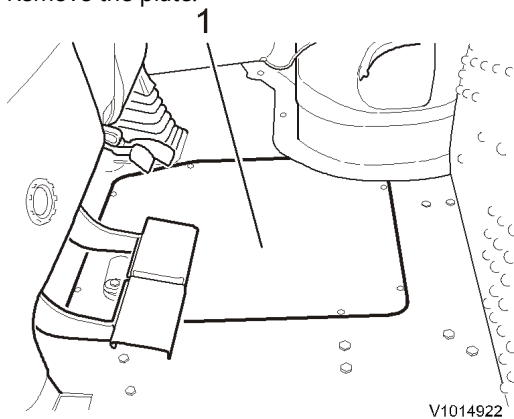

Figure 15

1. Plate

18. Remove the shift lever.

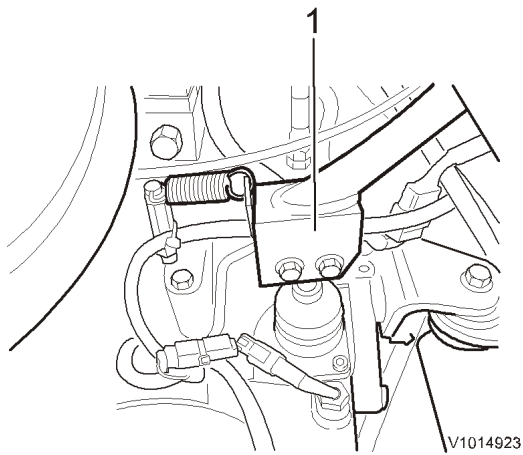

Figure 16

19. Disconnect the hoses from the gearbox.

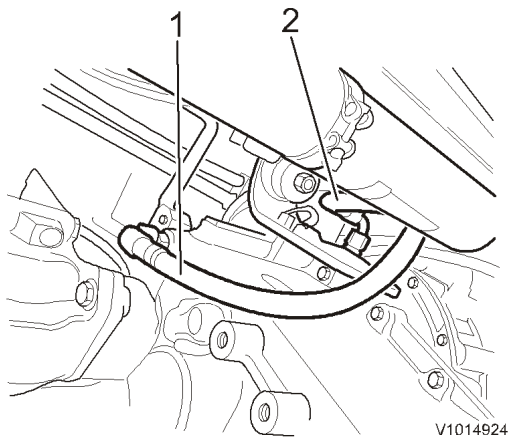
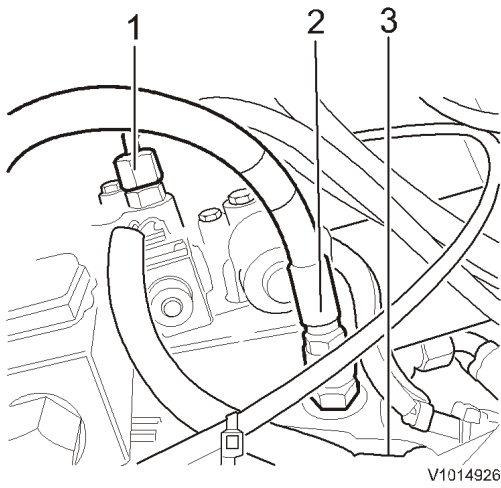

Figure 17

1. Hose
2. Hose

20. Disconnect the hoses from the gearbox.



V1014926

Figure 18

1. Hose
2. Hose
3. Hose

21. Disconnect the hose from the gearbox.

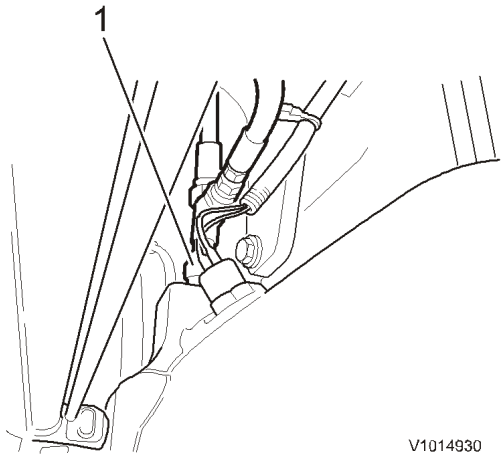

V1014930

Figure 19

1. Hose

22. Disconnect ground cables from the gearbox.

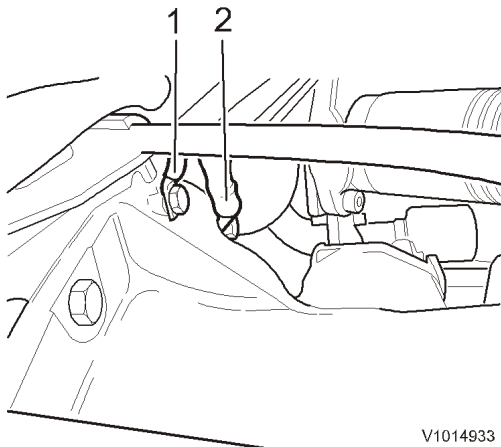

V1014933

Figure 20

Buy Now



Our support email:

ebooklibonline@outlook.com