

Document Title: <b>Engine, description</b>	Function Group: <b>200</b>	Information Type: <b>Service Information</b>	Date: <b>2015/3/6 0</b>
Profile: <b>EXC, EC140C LM [GB]</b>			

## Engine, description

### D4E - tier 3 compliant

The D4E configuration is a four stroke, straight four cylinder, turbocharged, direct injected diesel engine with charge air cooling and wet, replaceable cylinder liners.

The D4E engine uses a Common Rail Fuel System controlled by the engine electronic control (E-ECU) software.

Mechanically controlled IEGR (Internal Exhaust Gas Recirculation) reduces NO<sub>x</sub> formation and lowers emissions without the need for exhaust after treatment. Volvo's latest engine management system, E-ECU is used to control all engine electronic functions.

The cylinders are numbered consecutively beginning at the flywheel end. Engine rotational direction is counterclockwise as seen from the flywheel end.

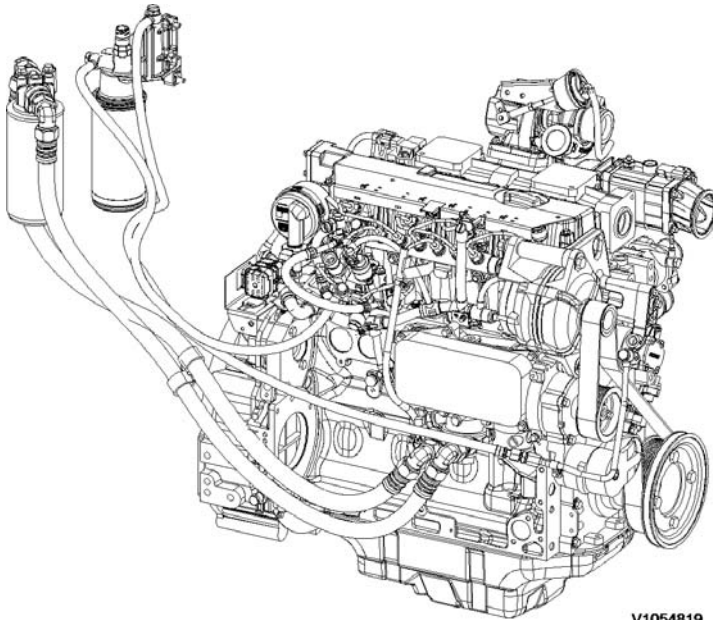

V1054819

**Figure 1**  
**Engine, D4E**

Document Title: <b>Engine, identification</b>	Function Group: <b>200</b>	Information Type: <b>Service Information</b>	Date: <b>2015/3/6 0</b>
Profile: <b>EXC, EC140C LM [GB]</b>			

## Engine, identification

### Identification plate

The engine model, serial number and performance data are stamped on an identification plate which is attached on the cylinder head cover. The engine model designation and serial number must be indicated when ordering spare parts.

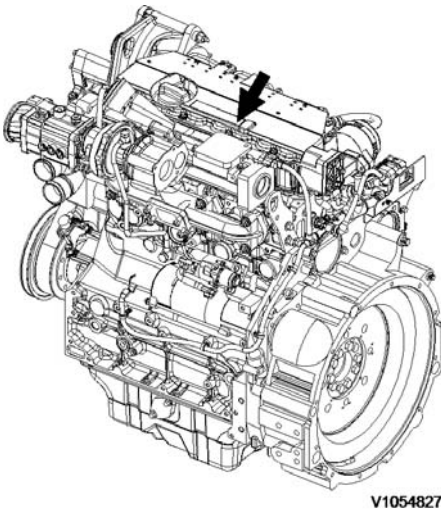

**Figure 1**  
**Engine identification, D4E**

Document Title: <b>Engine, tightening torques</b>	Function Group: <b>200</b>	Information Type: <b>Service Information</b>	Date: <b>2015/3/6 0</b>
Profile: <b>EXC, EC140C LM [GB]</b>			

## Engine, tightening torques

### NOTICE

Regarding bolted joints which are not listed here, see "Volvo standard tightening torques"

Engine, tightening torque	
Rocker arm bracket on cylinder head	30 Nm (22.2 lbf ft)
Cylinder head cover (M6) on cylinder head	13 Nm (9.6 lbf ft)
Exhaust return module on cylinder head	Step 1: 10 Nm (7.4 lbf ft) Step 2: 30 Nm (22.2 lbf ft)
Lock nut, valve adjusting screw	20 ±2 Nm (14.8 ±1.5 lbf ft)
Locking screw on cylinder head	34 Nm (25.2 lbf ft)
Solenoid valve on cylinder head	24 Nm (17.8 lbf ft)
Front cover on crankcase	Step 1: 3 Nm (2.2 lbf ft) Step 2: 21 Nm (15.5 lbf ft)
Drain plug on oil pan, M18	55 Nm (40.7 lbf ft)
Crankcase ventilation on cylinder head	21 Nm (15.5 lbf ft)
Return line to return stop valve	30 Nm (22.2 lbf ft)
Return stop valve to crankcase	80 Nm (59.2 lbf ft)
Impulse transmitter (crankshaft) on holder on front cover	9 Nm (6.7 lbf ft)
Impulse transmitter (camshaft) on gearcase	9 Nm (6.7 lbf ft)
Turbocharger on exhaust manifold	42 Nm (31.1 lbf ft)
Clamping shoe injector on cylinder head	16 Nm (11.8 lbf ft)
Injection lines on rail and injector, high pressure line on high-pressure pump	25 Nm (18.5 lbf ft)
Fuel supply pump on holder	22 Nm (16.3 lbf ft)
Holder fuel supply pump on holder	30 Nm (22.2 lbf ft)
V-belt pulley on fuel supply pump	27 Nm (20.0 lbf ft)
High pressure pump on crankcase, M10	Step 1: 10 Nm (7.4 lbf ft) Step 2: 50 Nm (37.0 lbf ft)
Fuel control valve	30 Nm (22.2 lbf ft)
Fuel pipe on high pressure pump	29 Nm (21.5 lbf ft)
Fuel pipe on control block	39 Nm (28.9 lbf ft)
Rail on cylinder head	30 Nm (22.2 lbf ft)
Pressure relief valve on rail	100 Nm (74.0 lbf ft)
Rail pressure sensor on rail	70 Nm (51.8 lbf ft)
Pipe clips, fuel line fastening	30 Nm (22.2 lbf ft)
Fuel line on control block, fuel filter console and rail	39 Nm (28.9 lbf ft)
Fuel pipe (return) on control block	49 Nm (36.3 lbf ft)
Fuel pipe (return) on cylinder head	29 Nm (21.5 lbf ft)
Fuel line on fuel filter8	39 Nm (28.9 lbf ft)
Fuel filter console/radiator tank on crankcase	30 Nm (22.2 lbf ft)

Fuel pressure sensor on fuel filter console	30 Nm (22.2 lbf ft)
Cover plate on cylinder cover, M6	30 Nm (22.2 lbf ft)

Document Title: <b>Component locations</b>	Function Group: <b>200</b>	Information Type: <b>Service Information</b>	Date: <b>2015/3/6 0</b>
Profile: <b>EXC, EC140C LM [GB]</b>			

## Component locations

Component position, engine D4E. The following figures show the position of a number of components on engine D4E.

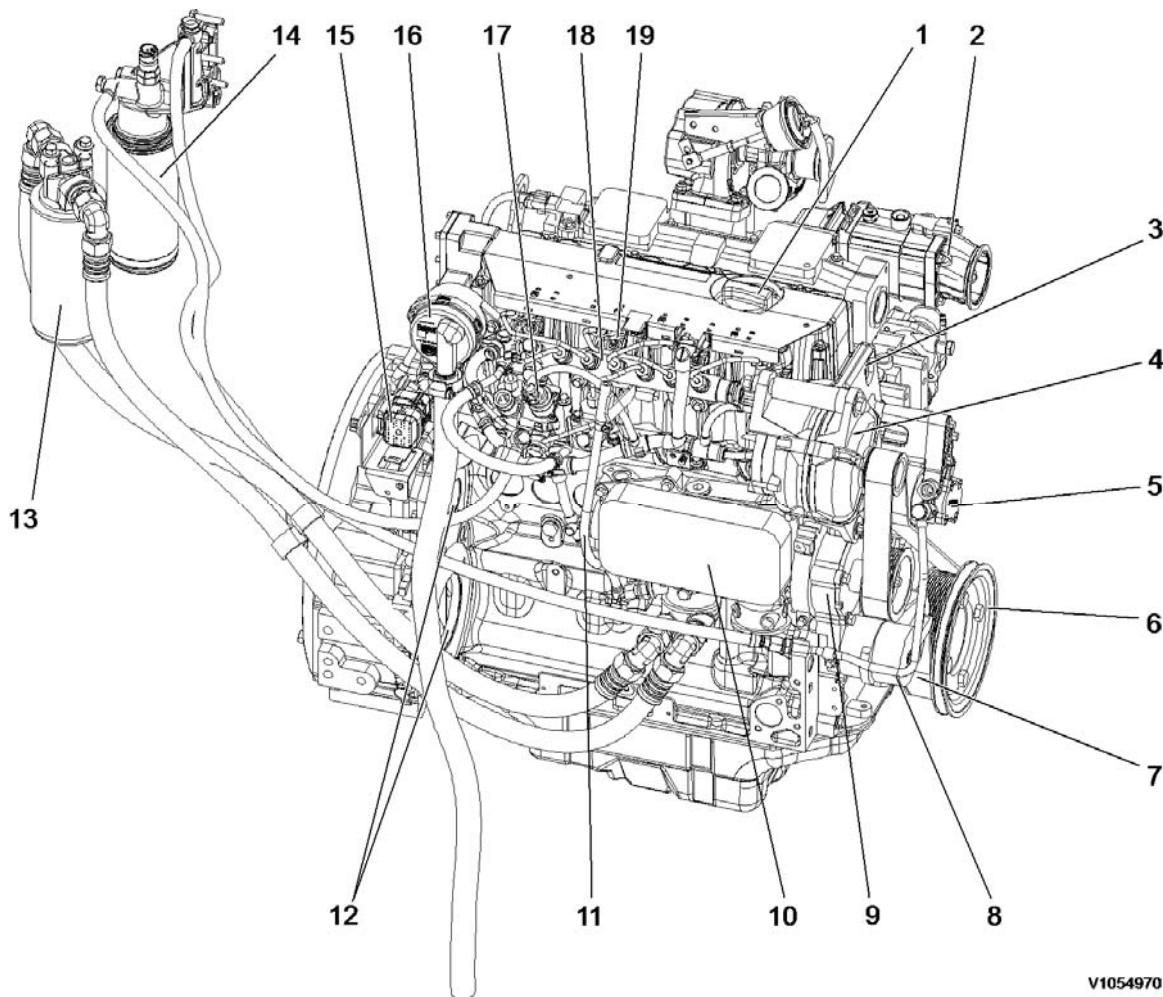

V1054970

**Figure 1**  
**Component locations, front side**

1	Engine oil filler	11	Oil dipstick
2	Air inlet	12	Power take off
3	Transport eye	13	Engine oil filter
4	Alternator	14	Fuel filter
5	Fuel feed pump	15	Connection to E-ECU
6	V-rib belt drive on crankshaft	16	Crankcase bleeding valve
7	V-rib belt	17	High pressure fuel pump
8	Automatic belt tensioner	18	Common rail
9	Coolant pump	19	Injector
10	Engine oil cooler		

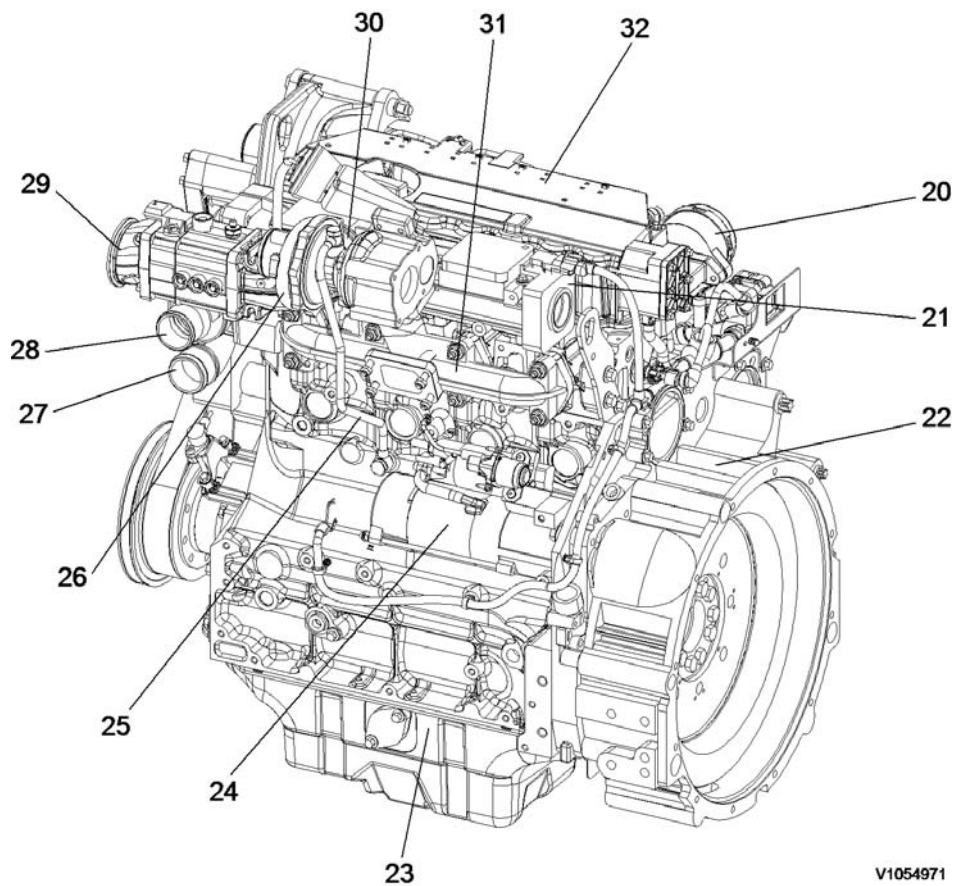

V1054971

**Figure 2**  
**Component locations, flywheel side**

20	Crankcase bleeding valve	27	Coolant inlet
21	Charge air manifold	28	Coolant outlet
22	Flywheel housing	29	Air inlet (from charge air cooler)
23	Oil pan	30	Air outlet (to charge air cooler)
24	Start motor	31	Exhaust manifold
25	Oil return line from turbocharger	32	Cylinder rocker arm cover
26	Turbocharger		

Document Title: <b>Engine characteristic curve</b>	Function Group: <b>210</b>	Information Type: <b>Service Information</b>	Date: <b>2015/3/6 0</b>
Profile: <b>EXC, EC140C LM [GB]</b>			

## Engine characteristic curve

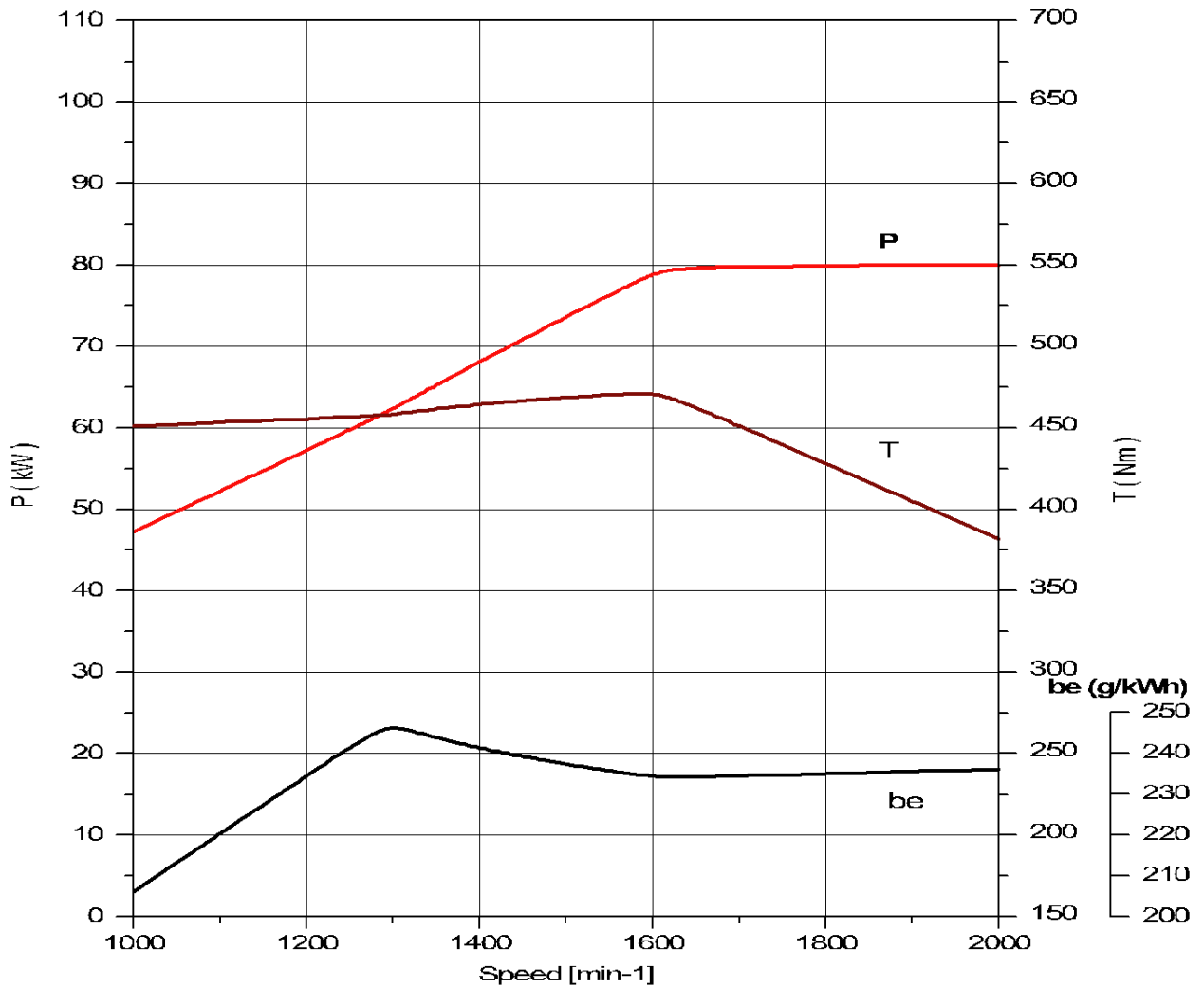

V1056835

**Figure 1**  
**Engine, characteristic curve**

P	Output power
S	Engine speed
T	Torque
be	Fuel consumption

Document Title: <b>Basic check, Engine</b>	Function Group: <b>210</b>	Information Type: <b>Service Information</b>	Date: <b>2015/3/6 0</b>
Profile: <b>EXC, EC140C LM [GB]</b>			

## Basic check, Engine

### NOTE!

Certain tests and checks are performed with unlocked safety locking lever. Make sure that the machine cannot operate unexpectedly when the control lockout lever is unlocked.

### Purpose of the basic check

The purpose of the basic check is to provide fast and accurate information about the general condition of the engine.

The basic check should be performed and evaluated according to instructions in the PC-tool VCADS Pro.

### Tests included in the basic check

The basic check which is divided into the following tests should be performed after **reading out error codes and checking parameters**.

### Tests:

1. **Cylinder compression, test**  
The purpose of the test is to show if any cylinder has a deviating compression pressure. The test replaces the old pressure check method but does not give any absolute values.
2. **Feed pressure, test**  
The purpose of the test is to check that the feed pressure is as per specification.
3. **Sensor, test**  
The purpose of the test is to check the function of all sensors.



Document Title: <b>Troubleshooting</b>	Function Group: <b>210</b>	Information Type: <b>Service Information</b>	Date: <b>2015/3/6 0</b>
Profile: <b>EXC, EC140C LM [GB]</b>			

## Troubleshooting

### General about troubleshooting

When a malfunction is suspected or has been confirmed, it is important to identify the cause as soon as possible.

The starting point for all troubleshooting is that there is some type of trouble symptom or malfunction.

Malfunctions can be indicated by:

- generation of error codes
- detection of a malfunction symptom.

### Troubleshooting work

The first step in troubleshooting is to gather information from the operator concerning the malfunction symptoms, see Electrical and information system, Collection of basic data. Then, attempt to pin-point the cause by checking in a certain order, for more information, see Electrical and information system, troubleshooting strategy.

The different checking steps are:

- Check error codes
- Check parameters
- Perform basic check

### Troubleshooting information

The following is included in Electrical and information system and is used when troubleshooting:

1. **Troubleshooting strategy**  
Describes troubleshooting work, step by step.
2. **Troubleshooting, assistive devices**  
Brief summary of the assistive devices that are available for troubleshooting.
3. **Functional checks and tests, VCADS Pro**  
Brief description of VCADS Pro. For a detailed description, see VCADS Pro User's Manual.
4. **Error code information**  
Contains information regarding error code design, lists of all error codes and error code information about each error code.
5. **Components, troubleshooting and specifications**  
Contains methods and measuring values for troubleshooting of components. Also includes wiring diagrams and certain specifications.
6. **Parameters**  
Incorrectly set parameters may cause malfunction symptoms. The parameter list includes all limit and command values for parameters.
7. **Control units, functional description**  
Describes the functions of the control units, inputs and outputs as well as communication between the various control units.
8. **Control units, active and passive measuring**  
Contains measuring values for active and passive measuring of the ECUs.
9. **Software functions**  
Describes the pre-requisite conditions for the control and monitoring functions that are performed by the software in the ECUs.

Document Title: <b>Camshaft and flywheel signals, checking with VCADS Pro and oscilloscope</b>	Function Group: <b>210</b>	Information Type: <b>Service Information</b>	Date: <b>2015/3/6 0</b>
Profile: <b>EXC, EC140C, EC140C L, EC140C LM [GB]</b>			

## **Camshaft and flywheel signals, checking with VCADS Pro and oscilloscope**

**Op nbr 210-090**

[9990014 Break out harness](#)

[9990062 Cable](#)

[9998699 Adapter](#)

[88890040 Oscilloscope](#)

[VCADS Pro VCADS Pro Service Tool](#)

1. Connect 88890040 Oscilloscope to the VCADS Pro computer and perform 28420-3, Flywheel and camshaft signals, test.

**NOTE!**

Instructions for how to connect the equipment are described in the VCADS Pro operation.

**NOTE!**

To be able to start the oscilloscope operation when USB-interface is default in VCADS Pro, then 88890180 Interface must be connected to the computer. However, in this case the interface does not have to be connected to the machine.

For computers with only one USB-port, the interface configuration must be changed to 9998555. However, in this cases the interface does not have to be connected to the machine.

Detailed user support is available under the the menu Help in the software.

**NOTE!**

The function "Save" overwrites the original file. Therefore, choose "Save as..." to save the read-off.

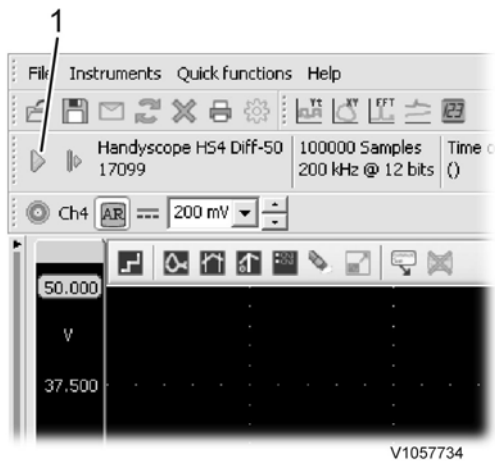

**Figure 1**

1. Click to start and stop the read-off

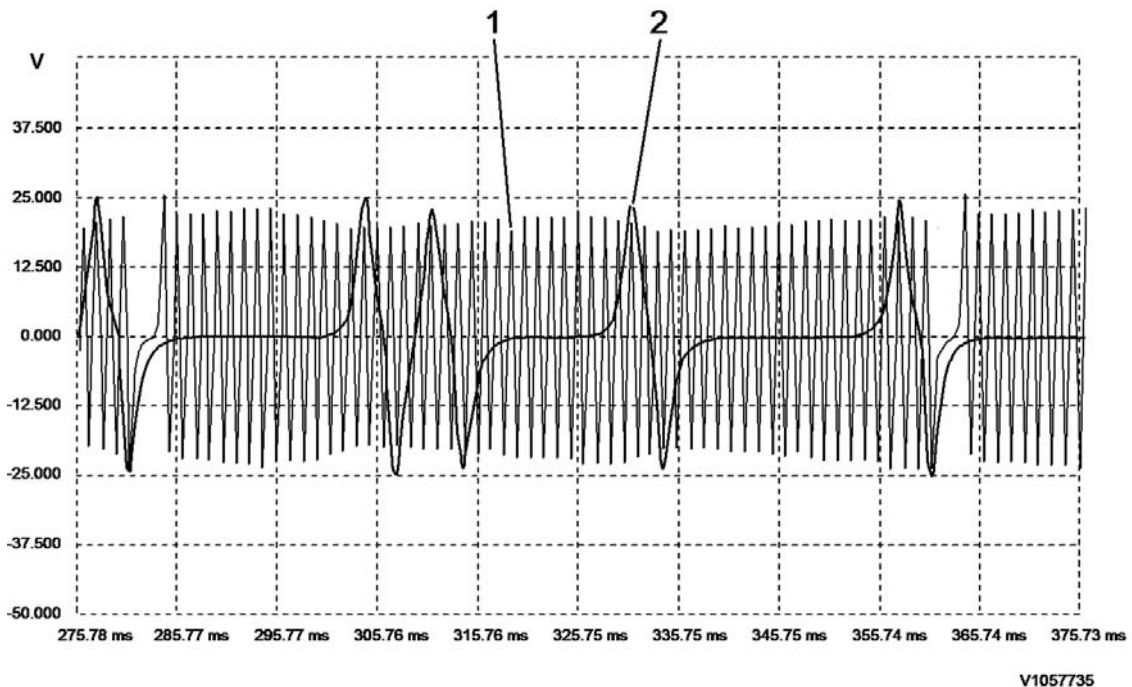
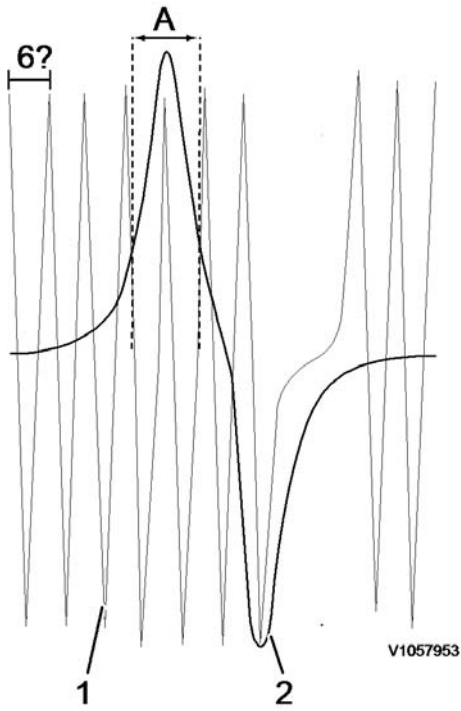

**Figure 2**

**Example of read-off of sensor signals with oscilloscope**

1. Signal from flywheel sensor
  2. Signal from camshaft sensor
2. Check that the signal from the camshaft sensor's signal coincides with the signal from the flywheel sensor within the marked area in the figure.
    - If the signal for the camshaft sensor is displaced **to the left** the camshaft is displaced **one gear tooth in the camshaft's rotational direction**.
    - If the signal for the camshaft sensor is displaced **to the right** the camshaft is displaced **one gear tooth opposite to the camshaft's rotational direction**.

For adjusting the camshaft's position, see service manual for respective engine.



**Figure 3**  
**Relationship between camshaft signal and flywheel signal**

- A. Area where the signal from the camshaft shall coincide with the signal from the flywheel sensor
- 1. Flywheel sensor
- 2. Camshaft sensor

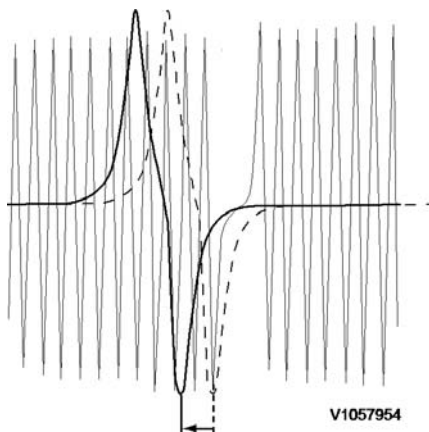

**Figure 4**  
**Example of incorrect signal**

In this case, the signal for the camshaft sensor is displaced to the left.

3. Check that the curves are not mirror-imaged (see figure). If the curves are mirror-imaged:
  - Check the connection to the oscilloscope.
  - If the connection to the oscilloscope is correct, check that the connections for the crankshaft sensor are installed correctly. If needed, unplug the connector for the flywheel sensor and change place of the cable connections.

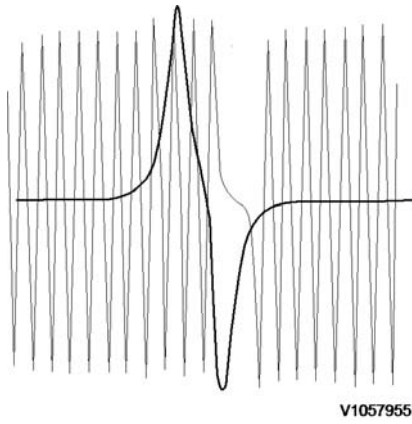

**Figure 5**  
**Example of incorrect signal**

In this case, the signal for the flywheel sensor is mirror-imaged

4. Check the voltage across the camshaft sensor.  
 To ensure reliable start and operation of the engine, the voltage across the sensors shall be according to [3021 SE2703, description and measuring](#) .

If the signal is too low:

- Check that the sensor is correctly installed and adjusted.
- Remove the sensor and check that it is not damaged. Check the distance between the sensor and the sensor ring gear is according to [386 Engine rotation speed sensor \(camshaft\), replacing](#). Install the sensor and check the signal again.

If the sensor is damaged, rotate the crankshaft and check if the camshaft gear has any damage that has caused damage to the sensor.

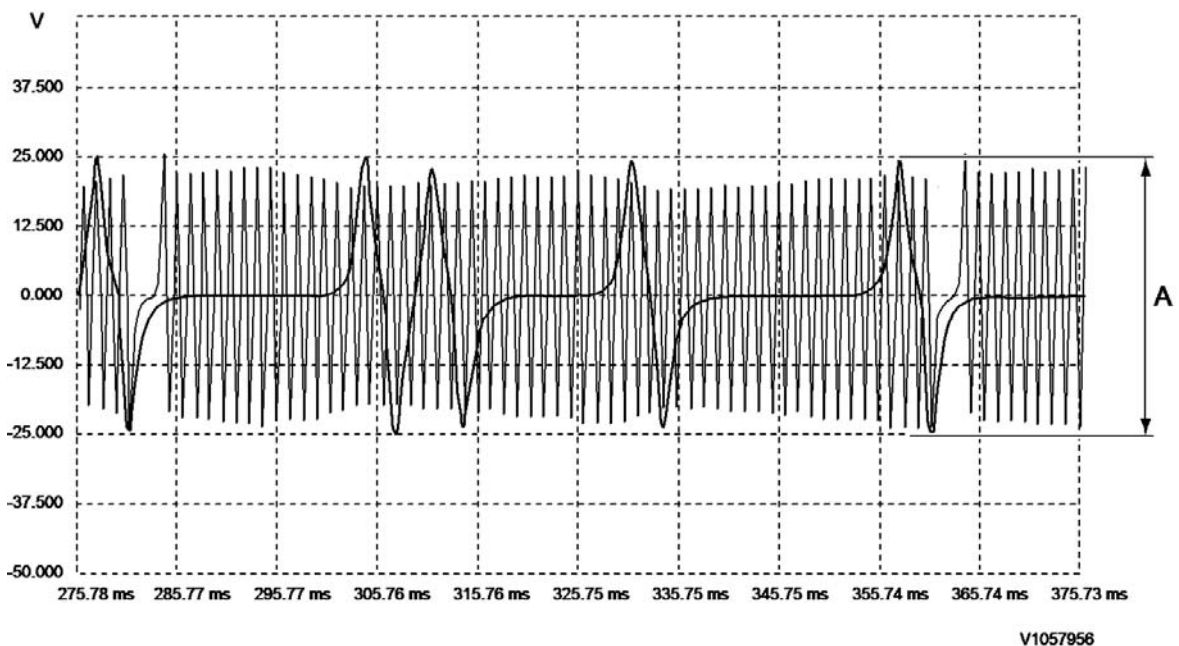

**Figure 6**

A. Signal voltage camshaft sensor (V)

5. Check the voltage across the flywheel sensor.  
 To ensure reliable start and operation of the engine, the voltage across the sensors shall be according to

[3021 SE2701. description and measuring](#)

If the signal is too low:

- Check that the sensor is correctly installed and adjusted.
- Remove the sensor and check that it is not damaged. Check the distance between the sensor and the sensor ring gear/flywheel is according to [386 Engine rotation speed sensor, replacing](#). Install the sensor and check the signal again.

If the sensor is damaged, rotate the crankshaft and check if the flywheel has any damage that has caused damage to the sensor.

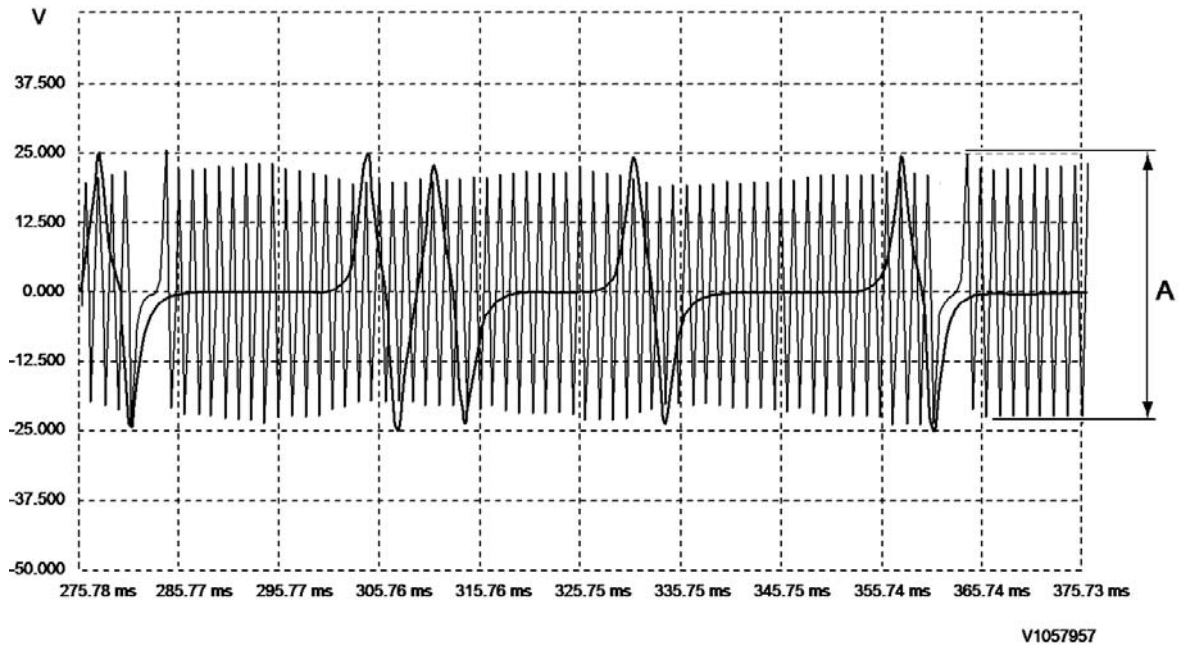

**Figure 7**

A. Signal voltage flywheel sensor (V)

**Buy Now**



Our support email:

[ebooklibonline@outlook.com](mailto:ebooklibonline@outlook.com)