

Document Title: <b>Engine, description (EC210)</b>	Function Group: <b>210</b>	Information Type: <b>Service Information</b>	Date: <b>2014/6/10</b>
Profile:			

## Engine, description (EC210)

(CUMMINS B5.9-C)

- The engine is a 6-cylinder, 4-stroke, direct injected, turbocharged, aftercooled, water cooled assembly with a cast iron block and cylinder head.
- Gears in the engine gear case are hardened helical type for strength and reduced noise, arranged to provide quiet, smooth transmission of power.
- The cylinder block and head are designed with internal passages formed as sets for lubrication and cooling. The water pump and oil cooler are integrally mounted.
- The fan belt is a poly type V-belt for improved performance and an auto tension adjuster maintains belt tension.

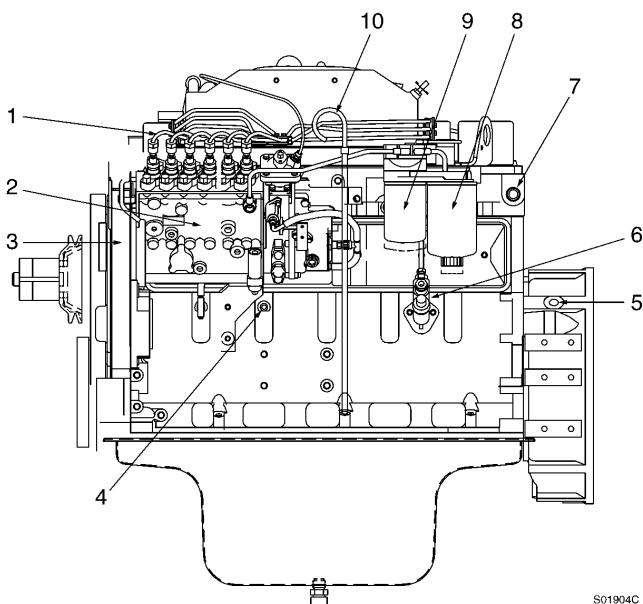

**Figure 1**  
**Engine, structure(EC210)**

1. High pressure fuel line
2. Fuel injection pump
3. Engine data plate
4. Engine oil pressure sensor port (M10 × 1.0)
5. Speed sensor port (3/4" 16UNF)
6. Fuel feed pump
7. Water temperature sensor (3/4" NPTF)
8. Primary fuel filter/water separator
9. Secondary fuel filter
10. Dipstick gauge

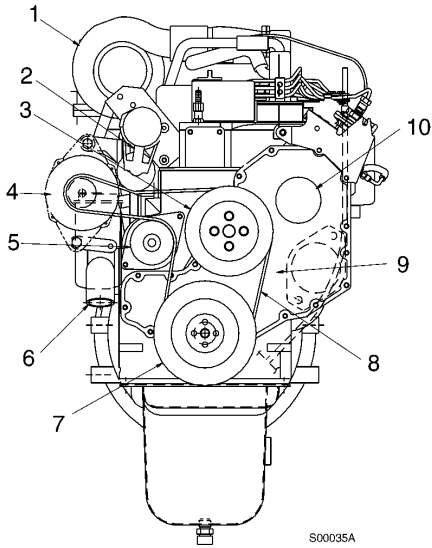

**Figure 2**  
**Engine, front view (EC210)**

- |                            |                                   |
|----------------------------|-----------------------------------|
| 1 Turbocharger             | 6 Water inlet                     |
| 2 Automatic belt tensioner | 7 Vibration damper                |
| 3 Fan pulley               | 8 Fan belt                        |
| 4 Alternator               | 9 Gear cover                      |
| 5 Water pump               | 10 Fuel injection pump gear cover |

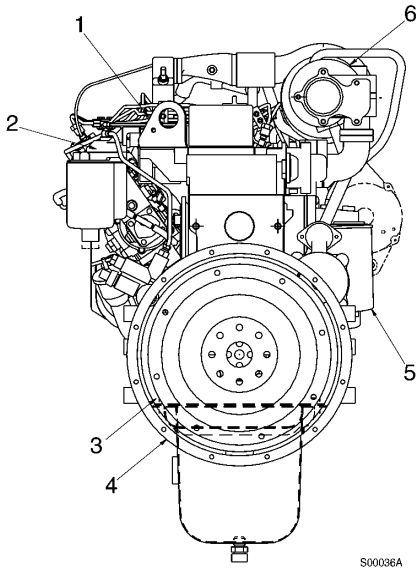
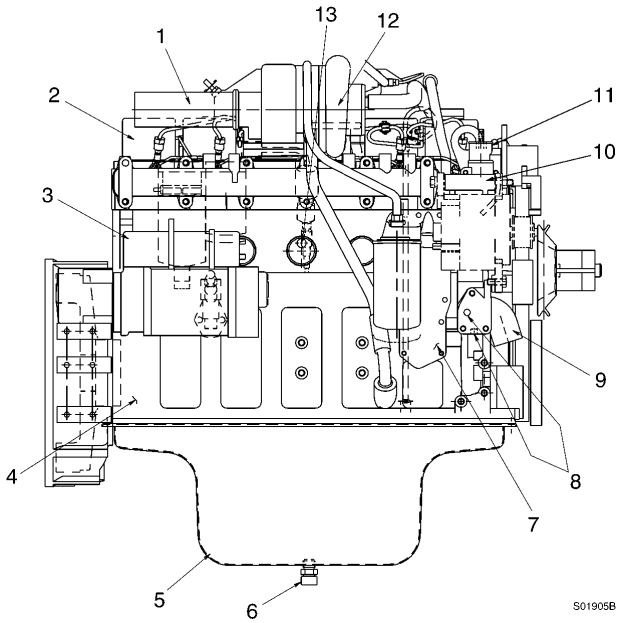

**Figure 3**  
**Engine, rear view (EC210)**

1 Engine lifting eye	4 Flywheel housing
2 Fuel filter head	5 Engine oil filter
3 Flywheel	6 Turbocharger

**NOTE!**

For detailed information on the engine, consult the separate engine service manual.



S01906B

**Figure 4**  
**Engine turbocharger, side view (EC210)**

1. Exhaust gas discharge port
2. Valve cover
3. Starter
4. Engine block
5. Oil pan
6. Engine oil drain valve (M22 X 1.5P)
7. Engine oil cooler
8. Water temperature switch port (PT 1/2")
9. Water inlet
10. Alternator
11. Thermostat / Water outlet
12. Turbocharger
13. Block heater port

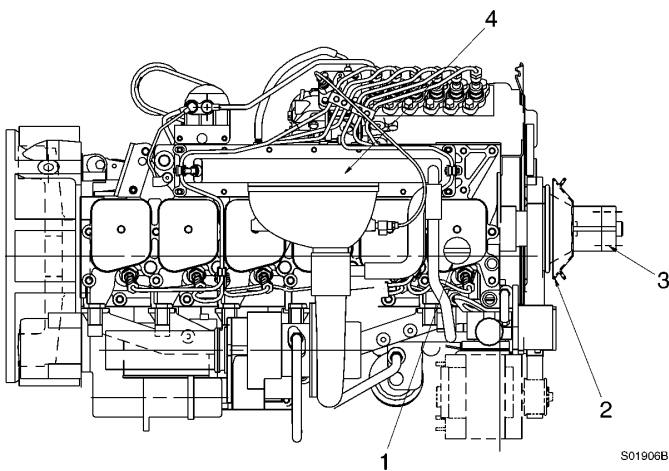

S01906B

**Figure 5**  
**Engine, top view (EC210)**

1. Engine oil refill plug
2. Air conditioner compressor drive pulley
3. Fan spacer

4. After cooler

**Engine characteristic curve**

**Engine characteristics**

Specification	KSR 1004
Rated output	145 ps / 1900 rpm
Max. torque (Net)	63 kgf·m / 1500 rpm (455 lbf·ft / 1500 rpm)
Min. fuel consumption	151 g / ps-h
Rated fuel consumption	158 g / ps-h

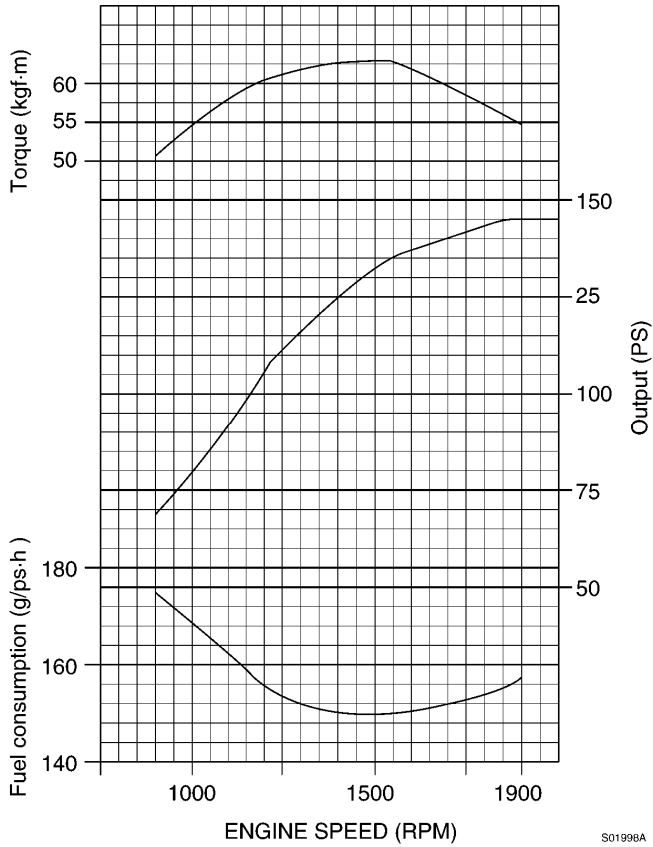

**Figure 6**  
**Engine, characteristic curve (EC210)**

**NOTE!**

For detailed information on the engine, consult the separate engine service manual.

Document Title: <b>Valve clearance adjustment</b>	Function Group: <b>214</b>	Information Type: <b>Service Information</b>	Date: <b>2014/6/10</b>
Profile:			

## Valve clearance adjustment

### Cummins B5.9-C (EC210 series)

Valves must be correctly adjusted for the engine to operate efficiently. Valve adjustment must be performed using the specified values.

Adjust the valves at each 1000 hours or 1 year maintenance interval.

All the valve adjustments must be made when the engine is cold and stabilized coolant temperature is 60°C or below.

- Turn the valve adjustment screws in until touching the push rod sockets, and then loosen them one full turn. Use 1/2" drive, Part No. 3377371 Engine Barring Tool.

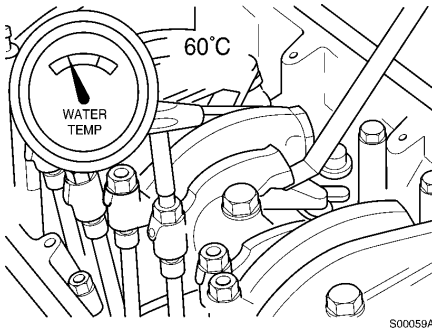

S00059A

**Figure 1**  
**Valve clearance adjustment condition**

- Locate top dead center for cylinder No.1 by rotating the crankshaft slowly while pressing on the engine timing pin. When the pin engages the hole in the camshaft gear, cylinder No.1 is at top dead center on the compression stroke.

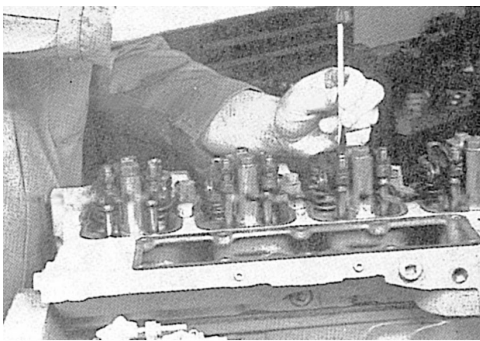

S00060A

**Figure 2**  
**Valve clearance**

Inlet valve	0.25 mm	0.010 in
Exhaust valve	0.51 mm	0.020 in

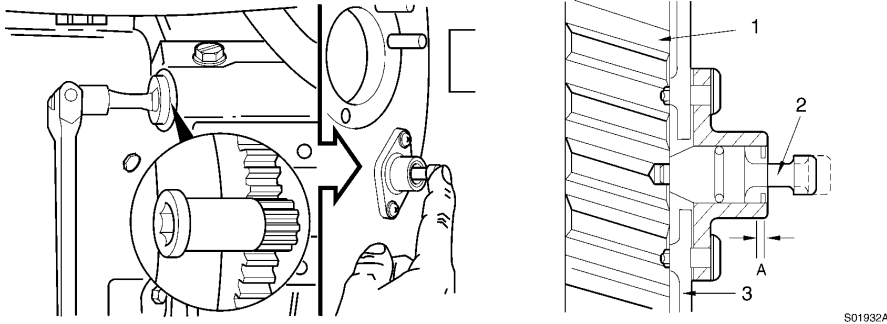
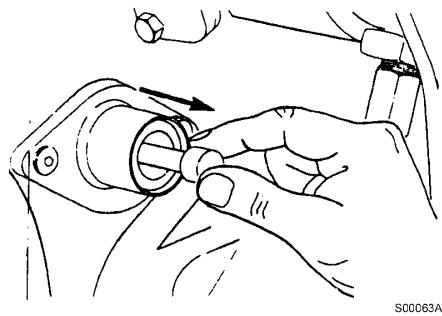

**Figure 3**  
**Rotation, camshaft gear**

1. Camshaft gear
  2. Timing pin
  3. Gear housing
- A. Compression stroke

**CAUTION**

Disengage the timing pin. Engine components may be damaged if the engine is rotated with the timing pin engaged.



**Figure 4**  
**Removal, timing pin**

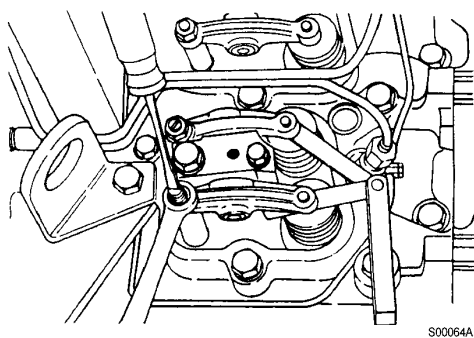

**Figure 5**  
**Adjustment, clearance between the valve stem and rocker lever**

Tools : 14 mm spanner, "–" screwdriver, feeler gauge.

- The clearance is correct when slight resistance is felt as the feeler gauge is moved between the valve stem and rocker lever. At that point, tighten the lock nut. (Tightening torque : 24 N·m)
- Adjust the valves indicated (\*) in the table below.

- After tightening the lock nut, check the valve clearance again. If the clearance is not correct, readjust.

**Valves to be adjusted (\*)**

Cylinder	1	2	3	4	5	6
Inlet (I)	*	*		*		
Exhaust (E)	*		*		*	

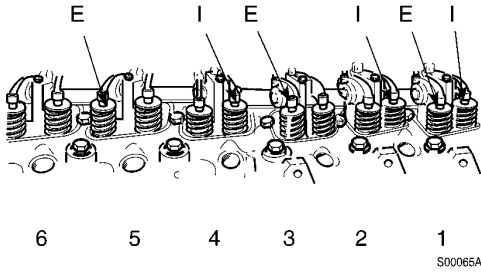

**Figure 6**  
**Valves to be adjusted**

**CAUTION**

Be sure the timing pin is disengaged.

**NOTE!**

Mark the crankpulley and cover.

**NOTE!**

Rotate the crankshaft 360°.

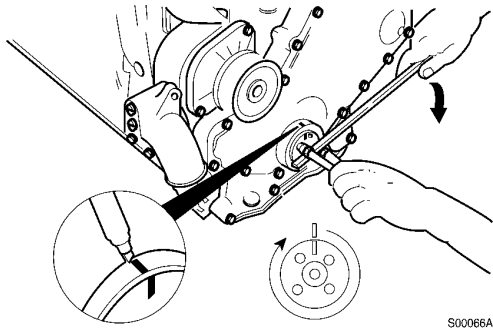
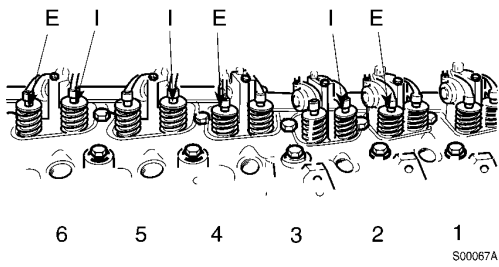

**Figure 7**  
**Marking, crankpulley**

- Adjust the valves indicated (\*) in the table below.  
After tightening the lock nut, check the valve clearance again.  
If the clearance is not correct, readjust.

**Valves to be adjusted (\*)**

Cylinder	1	2	3	4	5	6
Inlet (I)			*		*	*
Exhaust (E)		*		*		*



**Figure 8**  
**Valves to be adjusted**

- Assemble the gaskets, valve covers, o-rings and special screws.

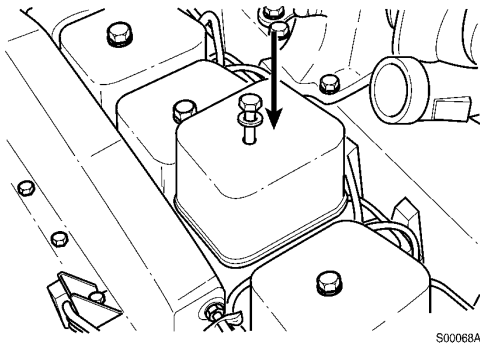

**Figure 9**  
**Assembly, valve covers**

Tools : 16 mm spanner  
Tightening torque : 24 N·m (18 lbf·ft)

**NOTE!**

Check valve covers and o-rings. If damaged, replace with a new one.

**Injection nozzles installation**

- Assemble a sealing washer on each injection nozzle. Use only one sealing washer.

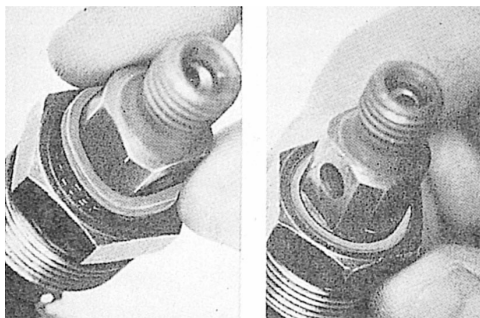

**Figure 10**  
**Assembly, injection nozzles**

- Apply anti-seize compound to the threads of the injector hold-down nut and between the top of the nut and injector body.



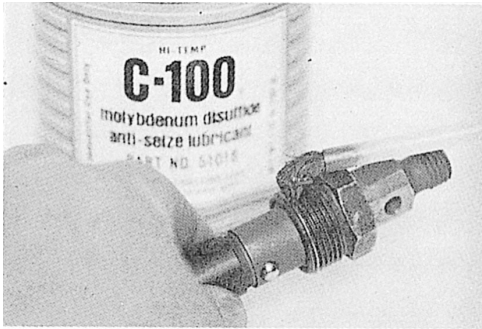

S00070A

**Figure 11**  
**Apply, anti-seize compound**

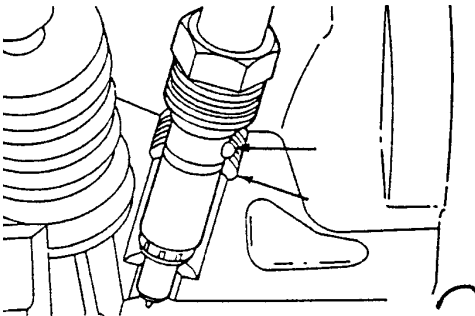

S00071A

**Figure 12**  
**Installation, injection nozzle**

Tools : 16 mm spanner, 24 mm Deep socket  
Tightening torque : 60 N·m (44 lbf·ft)

**NOTE!**

Install the injection nozzle. The protrusion on the injector body fits into a notch in the cylinder head to position the injector. Tighten the injection nozzle nuts.

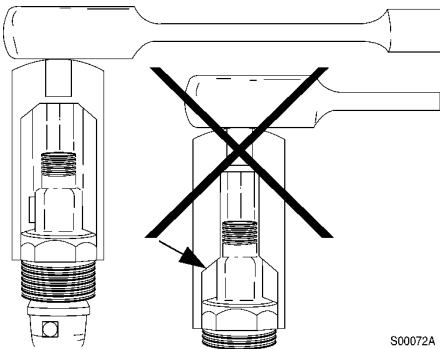

S00072A

**Figure 13**  
**Tightening, injection nozzle**

**NOTE!**

Some sockets can damage the sealing surface of the fuel drain outlet.

**Cummins C8.3-C (EC240 series)**

**Valve clearance adjustment**

Valves must be correctly adjusted for the engine to operate efficiently. Valve adjustment must be performed using the specified values.

Adjust the valves at each 1000 hours or 1 year maintenance interval.

All the valve adjustments must be made when the engine is cold, and stabilized coolant temperature is 60°C or below.

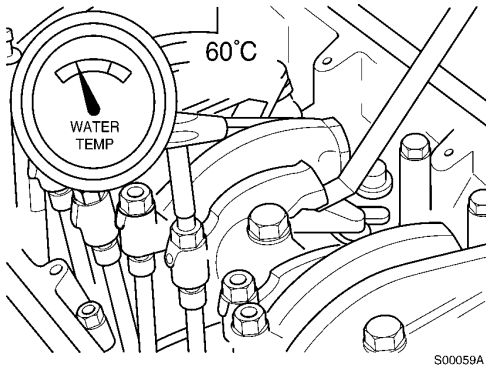
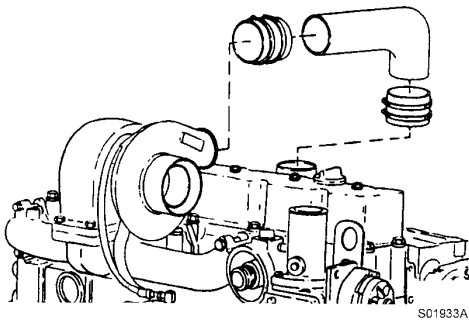

**Figure 14**  
**Adjustment condition**

**Valve clearance**

Inlet valve	0.30 mm	0.012 in
Exhaust valve	0.61 mm	0.024 in

- Remove the air inlet hose.



**Figure 15**  
**Removal, inlet hose**

- Remove the wastegate sensing line, support clamps and crankcase vent tube.

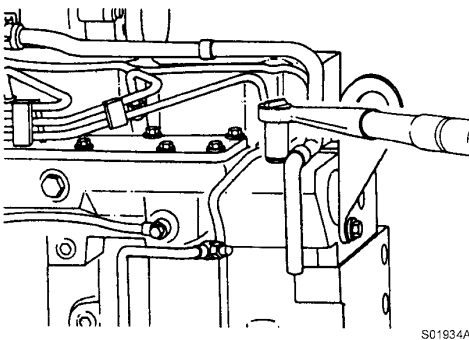

**Figure 16**  
**Removal, crankcase vent tube**

Tools : 13, 18 mm Socket

- Remove the valve cover.

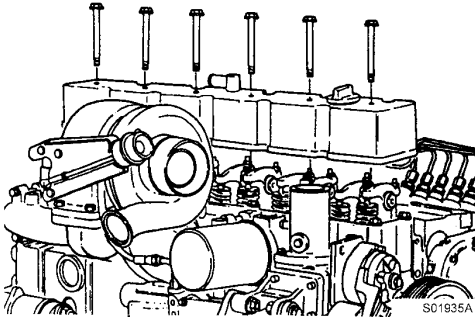

**Figure 17**  
**Removal, valve cover**

Tools : 15 mm Wrench

- Locate top dead center for cylinder No.1 by rotating the crankshaft slowly while pressing on the engine timing pin.

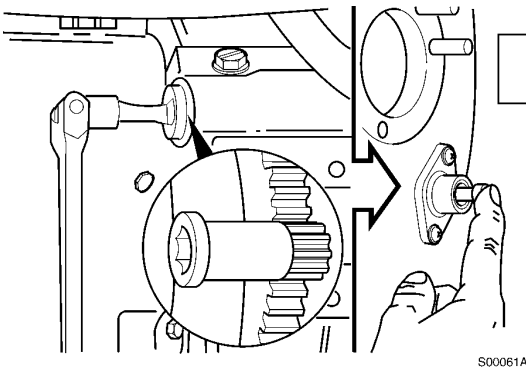

**Figure 18**  
**Rotation, camshaft gear**

Tools : 1/2" driver, Part No. 3377371 Engine Barring tool.

- When the pin engages the hole in the camshaft gear, cylinder No. 1 is at top dead center on the compression stroke.

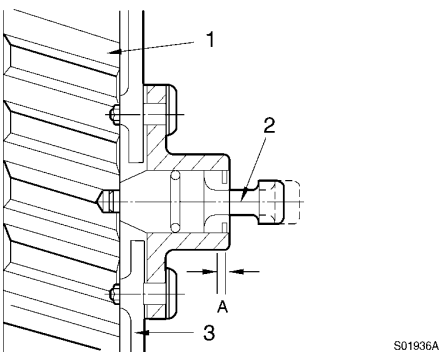
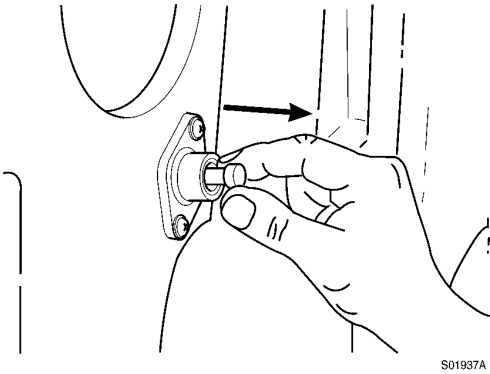

**Figure 19**  
**Position, cylinder No.1**

1. Camshaft gear
  2. Engine timing pin
  3. Gear housing
- A. Compression stroke

## **CAUTION**

Disengage the timing pin. Engine components may be damaged if the engine is rotated with the timing pin engaged.



**Figure 20**  
**Removal, timing pin**

## **CAUTION**

To prevent damage of push rod, make sure the adjusting screw ball is positioned in the socket of the push rod when tightening.

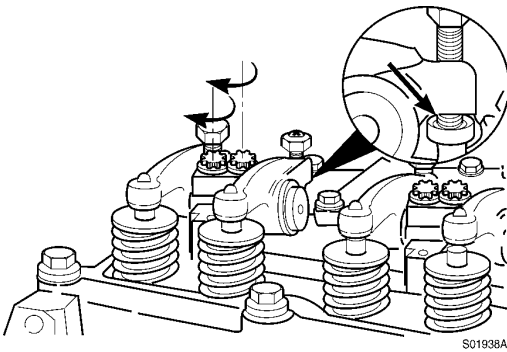

**Figure 21**  
**Position, adjusting screw ball**

- The clearance is correct when slight resistance is felt as the feeler gauge is moved between the valve stem and rocker lever.  
At that point, tighten the lock nut.

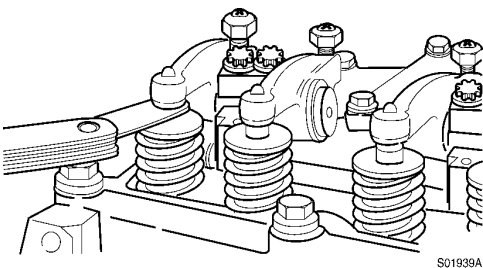

**Figure 22**  
**Checking, clearance**

Tools : Spanner 14mm, "-"- Driver, feeler gauge.

- Adjust the valves indicated (\*) in the table below.  
After tightening the lock nut, check the valve clearance again.

If the clearance is not correct, readjust.

**Valves to be adjusted (\*)**

Cylinder	1	2	3	4	5	6
Inlet (I)	*	*		*		
Exhaust (E)	*		*		*	

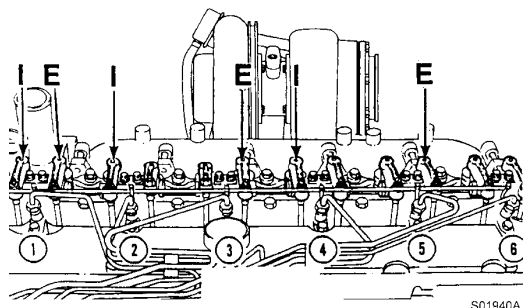
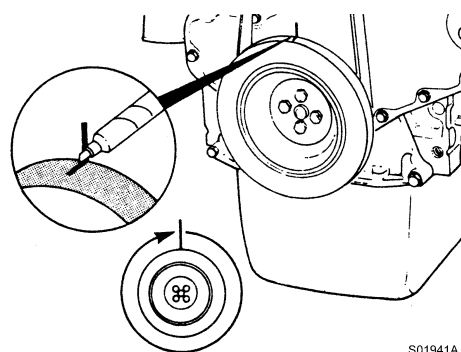

**Figure 23**  
**Valves to be adjusted**

**CAUTION**

Be sure the timing pin is disengaged.

- Mark the crankpulley and cover.
- Rotate the crankshaft 360°.

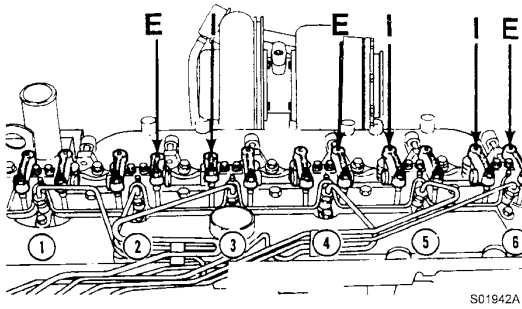

**Figure 24**  
**Marking, crankpulley**

- Adjust the valves indicated (\*) in the table below.  
After tightening the lock nut, check the valve clearance again.  
If the clearance is not correct, readjust.

**Valves to be adjusted (\*)**

Cylinder	1	2	3	4	5	6
Inlet (I)		*		*	*	
Exhaust (E)		*		*		*



S01942A

**Figure 25**  
**Valves to be adjusted**

**Valve cover–installation**

- Install the rubber seal into the groove in the valve cover. Start the installation at the overlap area shown in the illustration.

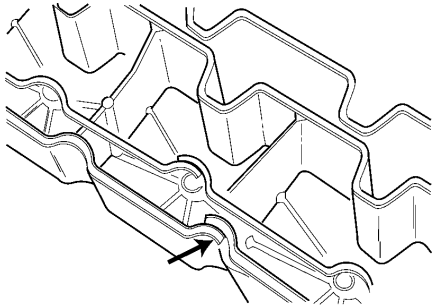

S01943A

**Figure 26**  
**Assembly, rubber seal**

- Do not stretch the rubber seal. If the seal has more overlap than shown in this illustration, trim the excess to provide the proper overlap.
- Install new o-rings on the valve cover screws.

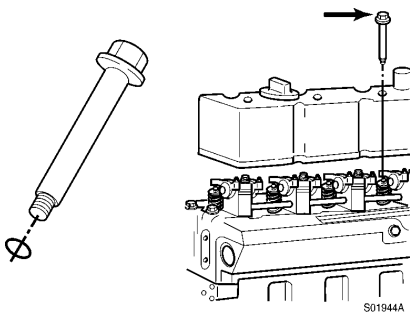

S01944A

**Figure 27**  
**Assembly, o-ring**

**NOTE!**

Engines equipped with wastegate turbochargers must have a studded screw installed in the third hole from the front. This is for the wastegate actuator hose clamp.

- Install the valve cover screws and tighten in the sequence shown.

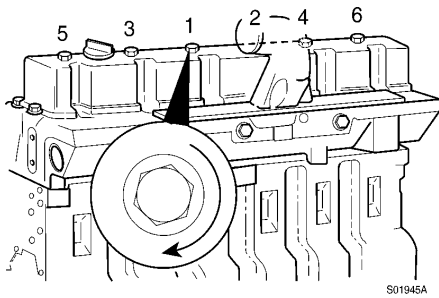
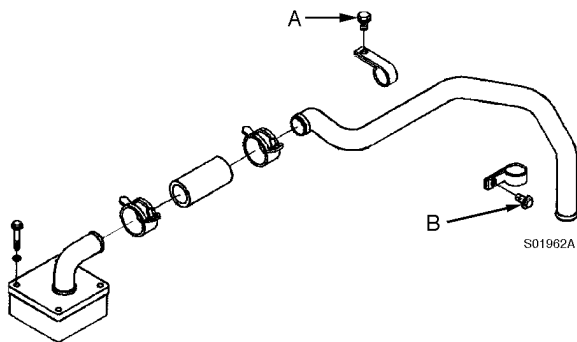

**Figure 28**  
**Screw tightening sequence**

Tools : 15 mm spanner  
Tightening torque : 24 N·m (18 lbf·ft)

**Crankcase breather tube–installation**

- Install the breather tube and hose clamps.
- Tighten the screws for the breather tube support brackets.

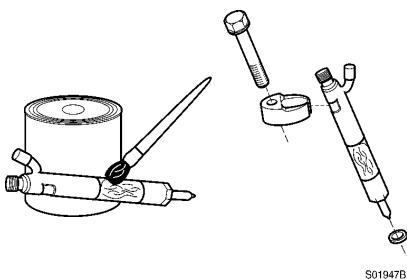

**Figure 29**  
**Assembly, breather tube**

Tightening torque : A = 24 N·m (18 lbf·ft), B = 43 N·m (32 lbf·ft)  
Tools : 13, 18 mm spanner

**Injection nozzles–installation**

- Lubricate the sealing lips of the sleeve with anti-seize compound. Assemble the injection nozzle, the sealing sleeve, a new copper washer and the hold-down clamp.
- Use only one washer.
- A light coat of clean 15W–40 engine oil between the washer and the injection nozzle will aid in holding the washer in place during installation.



**Figure 30**

### Apply, anti-seize compound

- Install the hold-down injection nozzle assembly into the injection nozzle bore. The injector leak-off connection must be toward the valve cover.

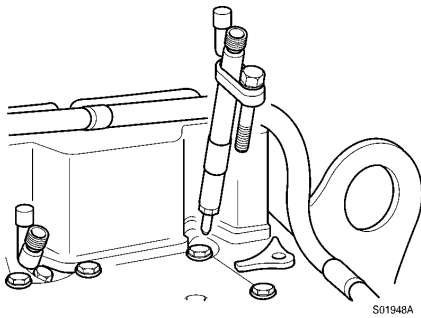

**Figure 31**  
**Assembly, injection nozzle**

- Install the hold-down screw.

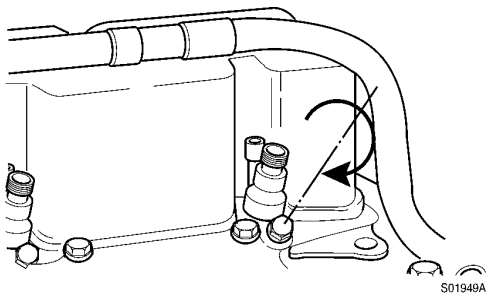

**Figure 32**  
**Screw in, hold-down screw**

Tightening torque : 24 N·m (18 lbf·ft)

Tools : 13 mm spanner



**Buy Now**



Our support email:

[ebooklibonline@outlook.com](mailto:ebooklibonline@outlook.com)