

Document Title: Engine, description	Function Group: 200	Information Type: Service Information	Date: 2014/10/11
Profile: EXC, EC290B FX [GB]			

Engine, description

Volvo D7D

The engine is a 6-cylinder, 4-stroke, direct injected, turbocharged, air to air aftercooled, water cooled assembly with a cast iron block and cylinder head.

This is a heavy duty diesel engines with a low swirl combustion process and a high pressure injection system with individual pumps.

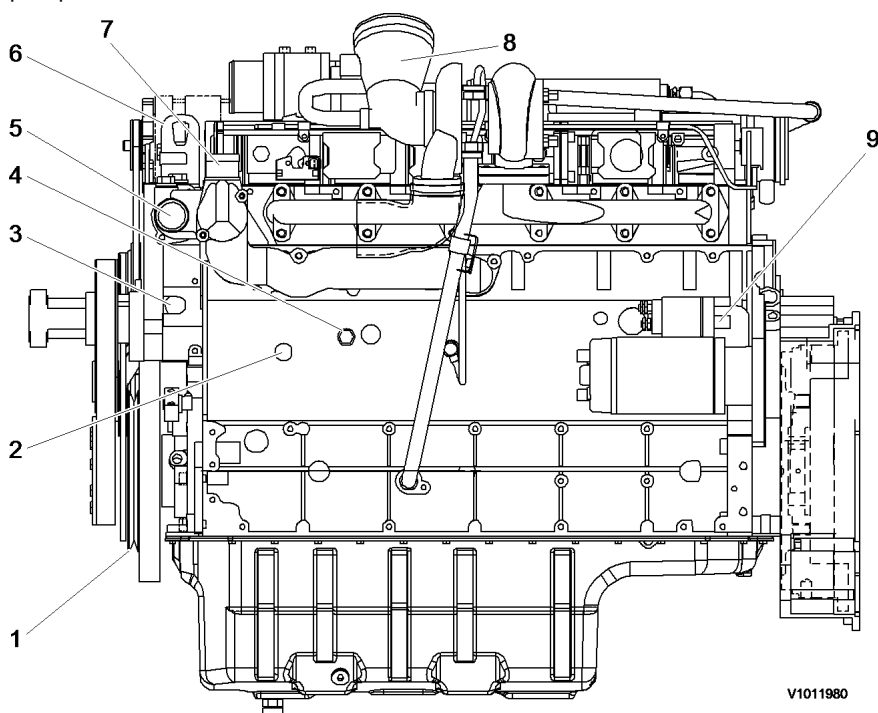
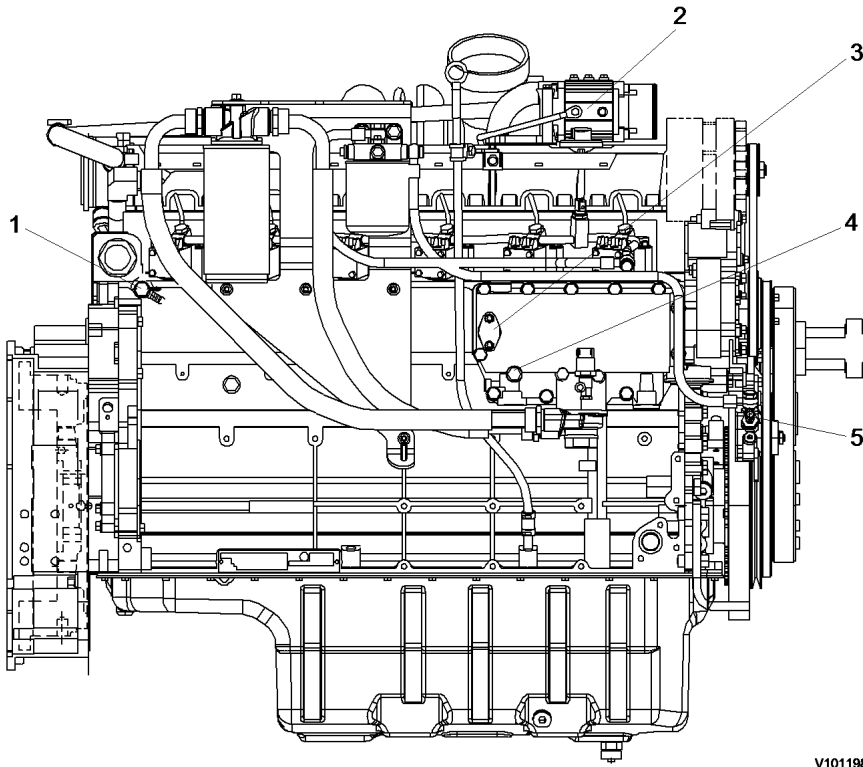

Figure 1

Engine, start motor side view

1. Air conditioner compressor pulley
2. Engine oil pressure sensor port
3. Make up line
4. Coolant temperature sensor port
5. Water inlet
6. Lifting lug
7. Water outlet
8. Air inlet
9. Start motor



V1011981

Figure 2
Engine, air heater side view

1. Fuel return line
2. Air heater
3. Coolant preheater port
4. Coolant filter supply
5. Fuel suction line

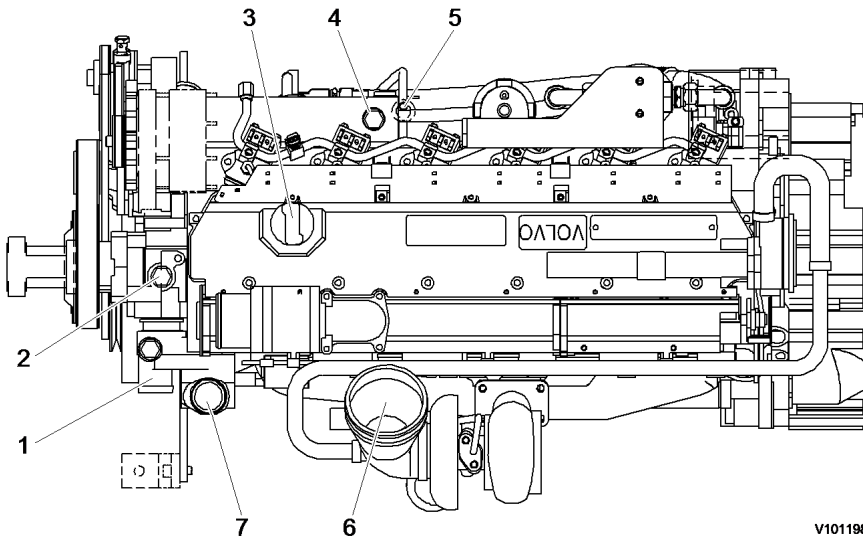

V1011982

Figure 3
Engine, top view

1. Water inlet
2. Return from heater
3. Engine oil filler
4. Supply to heater

5. Oil dipstick
6. Air inlet
7. Water outlet

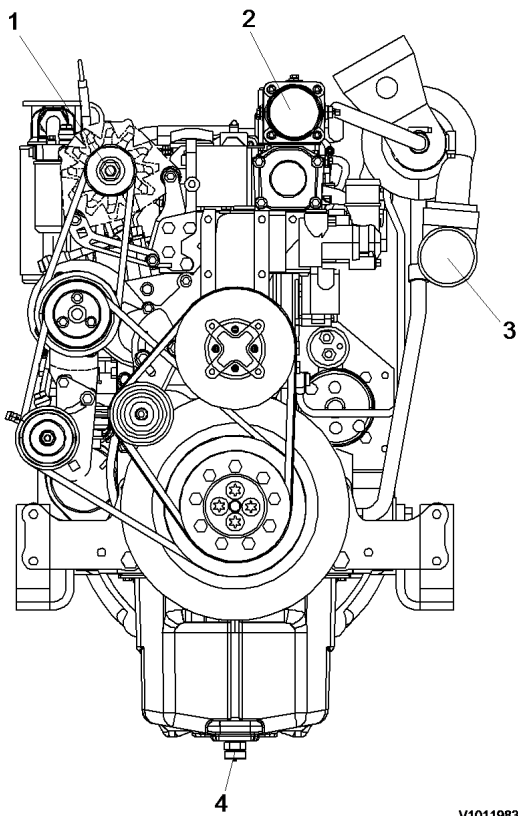

V1011983

Figure 4
Engine, front view

1. Alternator
2. From charge air cooler
3. To charge air cooler
4. Oil drain valve

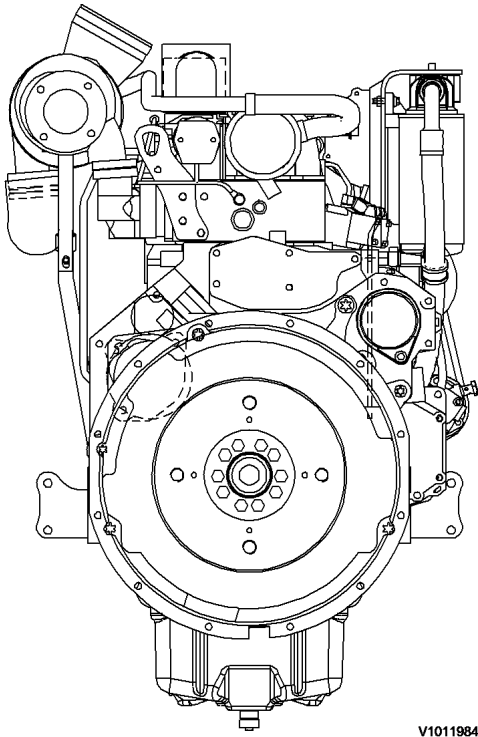

V1011984

Figure 5
Engine, rear view

Volvo D7E

The engine is a 6-cylinder, 4-stroke, direct injected, turbocharged, air to air aftercooled, water cooled assembly with a cast iron block and cylinder head.

This is a heavy duty diesel engines with a low swirl combustion process and a high pressure injection system with individual pumps.

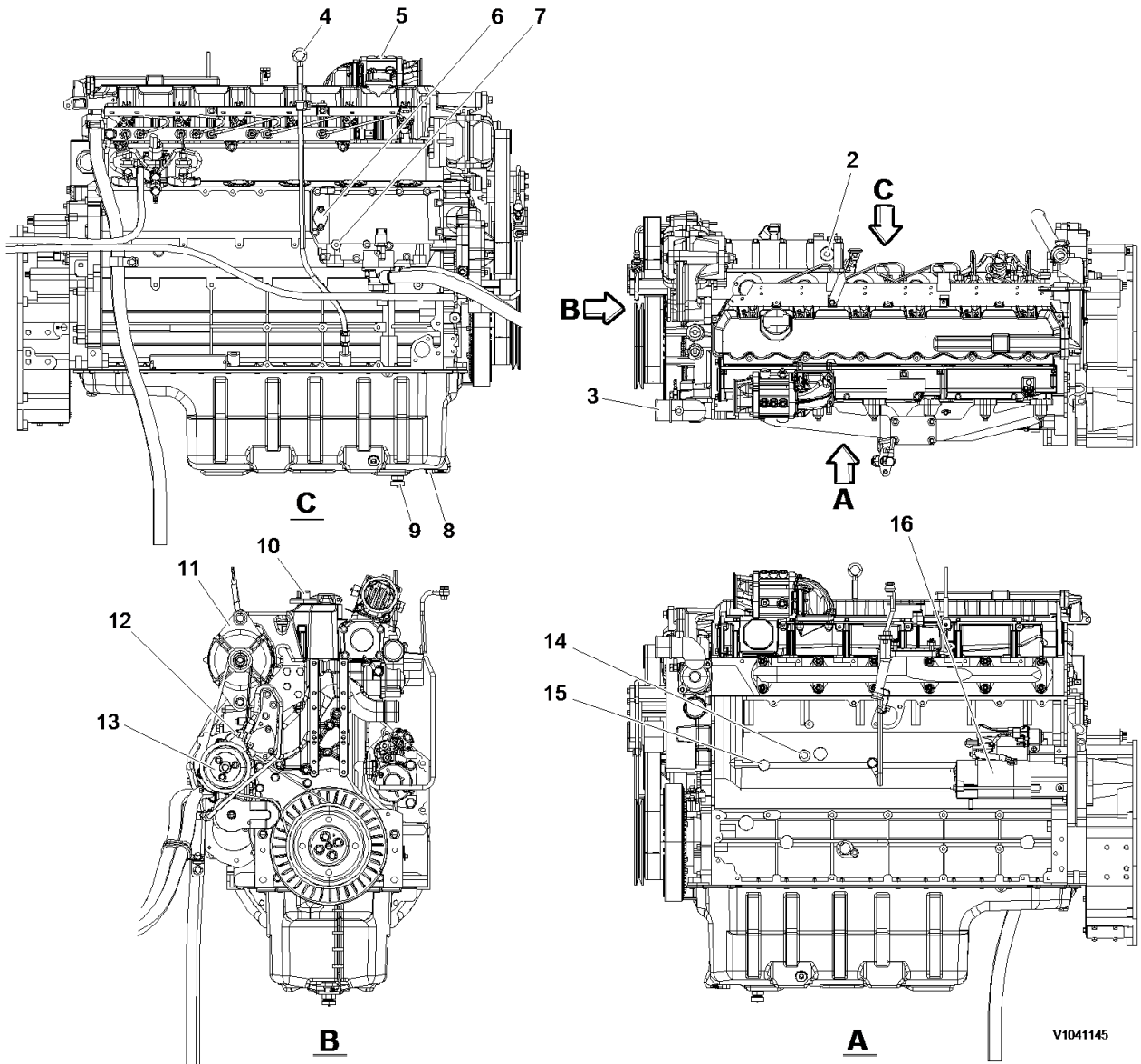

V1041145

Figure 6
Engine view (D7E EAE3)

- | | | | | | |
|---|----------------------------------|----|-----------------------|----|---------------------------------|
| 1 | Engine oil filler | 7 | Coolant filter supply | 13 | Compressor |
| 2 | Supply to heater | 8 | Oil level sensor | 14 | Coolant temp port |
| 3 | Return from heater (water inlet) | 9 | Oil drain valve | 15 | Engine oil pressure sensor port |
| 4 | Engine oil dipstick | 10 | Air vent connection | 16 | Start motor |
| 5 | Air heater | 11 | Alternator | | |
| 6 | Coolant preheater port | 12 | Fuel in suction port | | |

Document Title: Engine characteristic curve	Function Group: 210	Information Type: Service Information	Date: 2014/10/11
Profile: EXC, EC290B FX [GB]			

Engine characteristic curve

Item	Specifications
Rated output (Net)	143 kW (195 PS / 192 HP) at 1800 rpm
Maximum torque (Net)	965 N m (98 kgf m / / 714 lbf ft) at 1350 rpm
Fuel consumption	236 g / kW·h at 1800 rpm
	238 g / kW·h at 1350 rpm

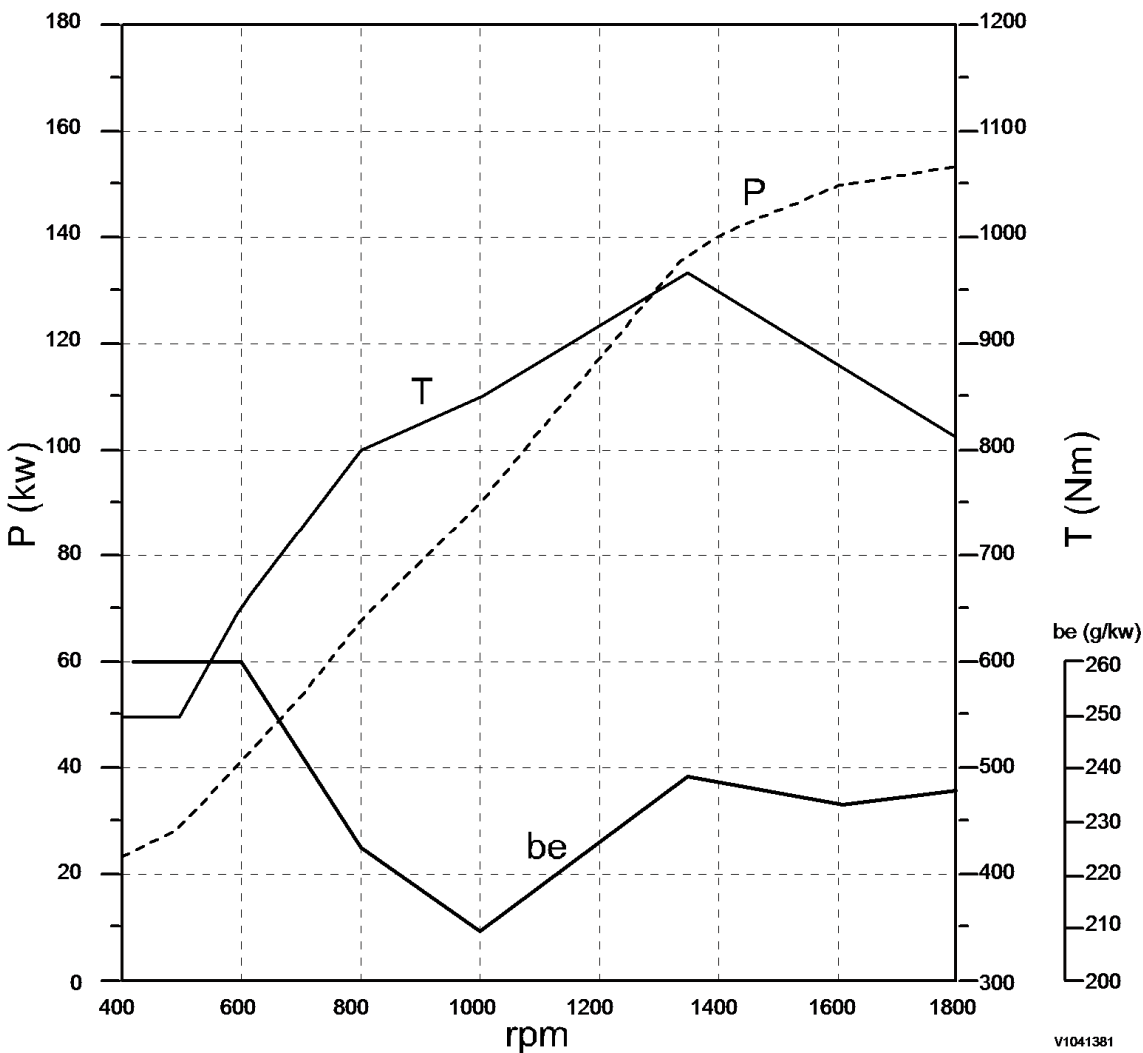

Figure 1
Engine, characteristic curve

- A be (g/kW/h) : Fuel consumption
- B T (N m) : Torque
- C rpm : Engine speed
- D P (kW) : Power

V1041381

Document Title: Basic check, Engine	Function Group: 210	Information Type: Service Information	Date: 2014/10/11
Profile: EXC, EC290B FX [GB]			

Basic check, Engine

NOTE!

Certain tests and checks are performed with unlocked safety locking lever. Make sure that the machine cannot operate unexpectedly when the safety locking lever is unlocked.

Purpose of the basic check

The purpose of the basic check is to provide fast and accurate information about the general condition of the engine.

The basic check should be performed and evaluated according to instructions in the PC-tool VCADS Pro.

Tests included in the basic check

The basic check which is divided into the following tests should be performed after **reading out error codes and checking parameters**.

Tests:

1. **Cylinder compression, test**
The purpose of the test is to show if any cylinder has a deviating compression pressure. The test replaces the old pressure check method but does not give any absolute values.
2. **Cylinder balancing, test**
The purpose of the test is to show if there is any deviation in the fuel injection to a cylinder.
3. **Feed pressure, test**
The purpose of the test is to check that the feed pressure is as per specification.
4. **Sensor, test**
The purpose of the test is to check the function of all sensors.

Document Title: Troubleshooting	Function Group: 210	Information Type: Service Information	Date: 2014/10/11
Profile: EXC, EC290B FX [GB]			

Troubleshooting

General about troubleshooting

When a malfunction is suspected or has been confirmed, it is important to identify the cause as soon as possible.

The starting point for all troubleshooting is that there is some type of trouble symptom or malfunction.

Malfunctions can be indicated by:

- generation of error codes
- detection of a malfunction symptom.

Troubleshooting work

The first step in troubleshooting is to gather information from the operator concerning the malfunction symptoms, see Electrical and information system, Collection of basic data. Then, attempt to pin-point the cause by checking in a certain order, for more information, see Electrical and information system, troubleshooting strategy.

The different checking steps are:

- Check error codes
- Check parameters
- Perform basic check

Troubleshooting information

The following is included in Electrical and information system and is used when troubleshooting:

1. **Troubleshooting strategy**
Describes troubleshooting work, step by step.
2. **Troubleshooting, assistive devices**
Brief summary of the assistive devices that are available for troubleshooting.
3. **Functional checks and tests, VCADS Pro**
Brief description of VCADS Pro. For a detailed description, see VCADS Pro User's Manual.
4. **Error code information**
Contains information regarding error code design, lists of all error codes and error code information about each error code.
5. **Components, troubleshooting and specifications**
Contains methods and measuring values for troubleshooting of components. Also includes wiring diagrams and certain specifications.
6. **Parameters**
Incorrectly set parameters may cause malfunction symptoms. The parameter list includes all limit and command values for parameters.
7. **Control units, functional description**
Describes the functions of the control units, inputs and outputs as well as communication between the various control units.
8. **Control units, active and passive measuring**
Contains measuring values for active and passive measuring of the ECUs.
9. **Software functions**
Describes the pre-requisite conditions for the control and monitoring functions that are performed by the software in the ECUs.

Document Title: Cylinder head, description	Function Group: 211	Information Type: Service Information	Date: 2014/10/11
Profile: EXC, EC290B FX [GB]			

Cylinder head, description

The cylinder head is made of grey cast iron and is common for all cylinders. The induction air enters vertically (A) and the exhausts leave horizontally (B). Inlets and exhaust outlets are located on the same side of the cylinder block. Inlet and exhaust valve size is increased to optimize the gas exchange and combustion process. Valve guides are replaceable. Coolant flow in the cylinder head is modified to accommodate an outlet controlled cooling system.

On order for the engine to fulfill governing emission standards, there are 3 cylinder head gaskets of different thicknesses between the cylinder head and the piston.

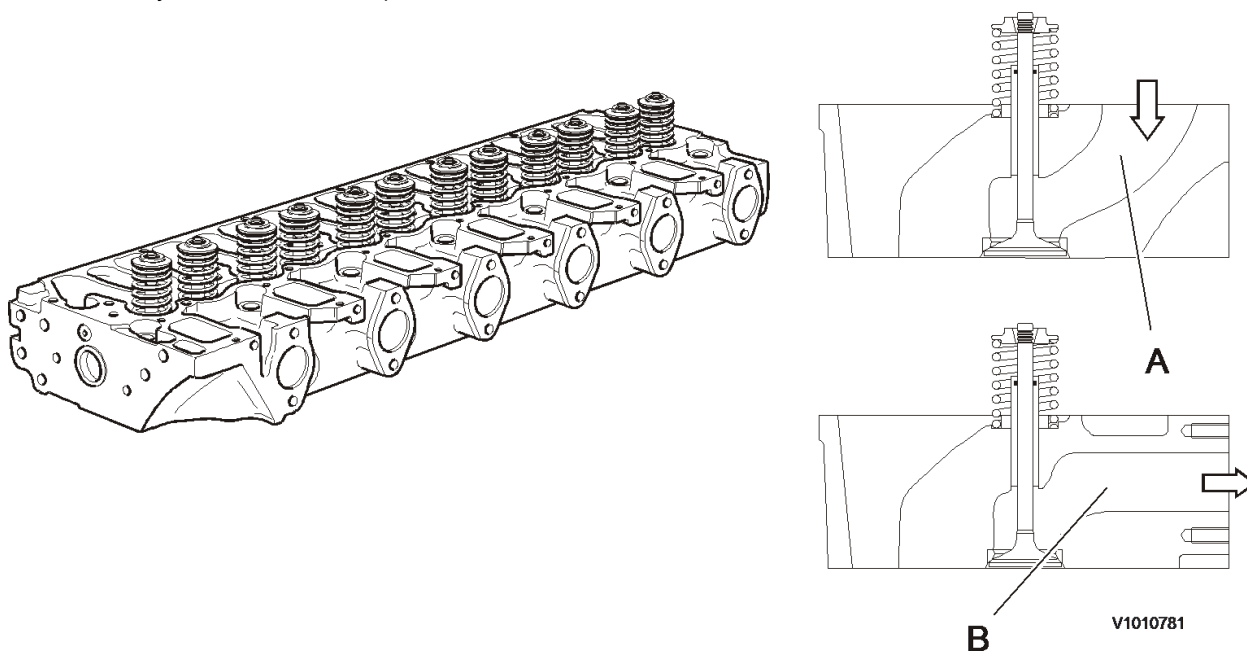

Figure 1

Document Title: Cylinder liner, description	Function Group: 213	Information Type: Service Information	Date: 2014/10/11
Profile: EXC, EC290B FX [GB]			

Cylinder liner, description

The engine has a cylinder block with wet (replaceable) cylinder liners. The bottom part of the liner is sealed against the cylinder block with two O-rings positioned in grooves machined into the lower end of the liner.

The upper part of the cylinder liner is sealed by the cylinder head gasket and the pressure created by the cylinder head clamping force against liner protrusion.

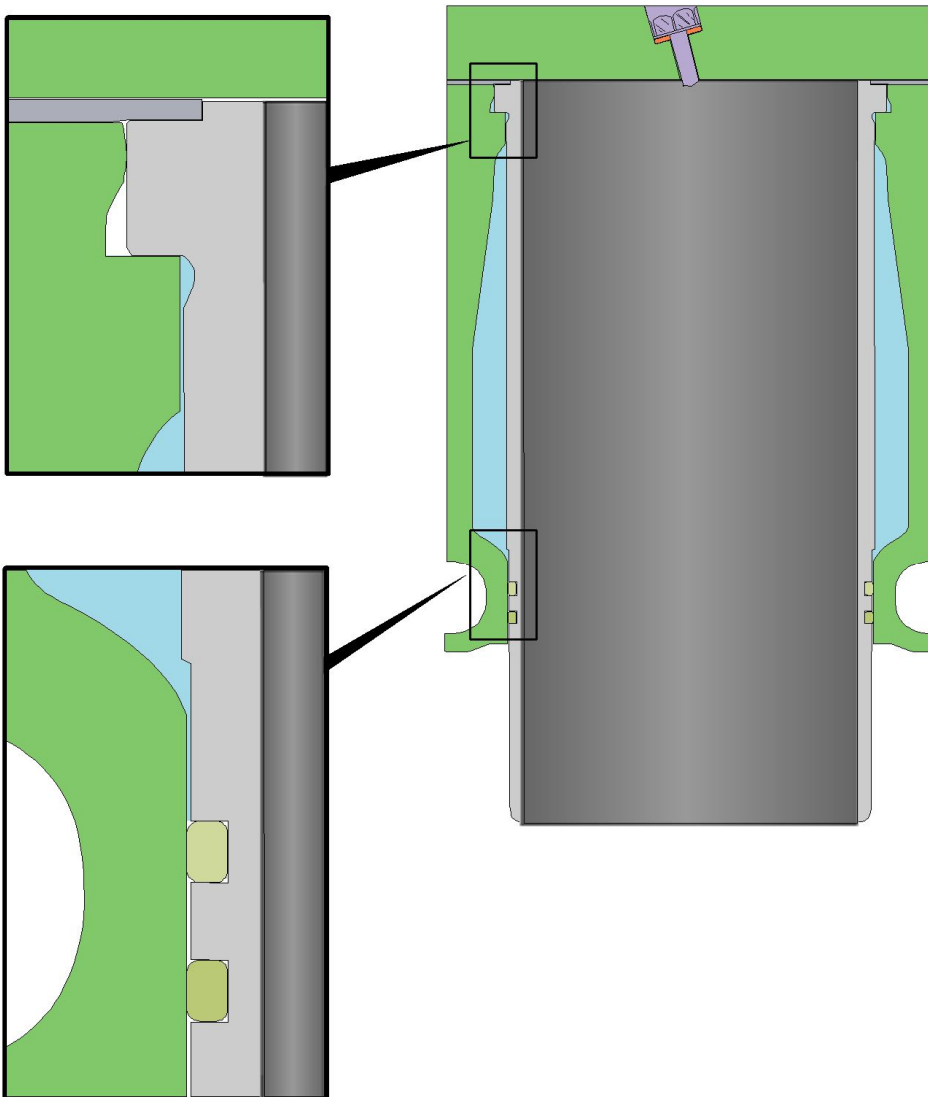

V1052529

Figure 1
Cylinder liner

Document Title: Pistons, description	Function Group: 213	Information Type: Service Information	Date: 2014/10/11
Profile: EXC, EC290B FX [GB]			

Pistons, description

The pistons of the engine are made of special alloy aluminium.

The top of the piston has a combustion cavity and a flywheel symbol to indicate the correct piston orientation.

Piston cooling is by oil spray to the inside of the piston from nozzles located in the main bearing pedestals.

The pistons are provided with three piston rings, two compression rings and one oil control ring.

The first or top compression ring has a cast iron carrier. The cross-section area for the second compression ring is tapered.

The third ring is an oil ring with a bevelled edge.

When installing the piston rings, the marking TOP by the opening in the rings must be face up.

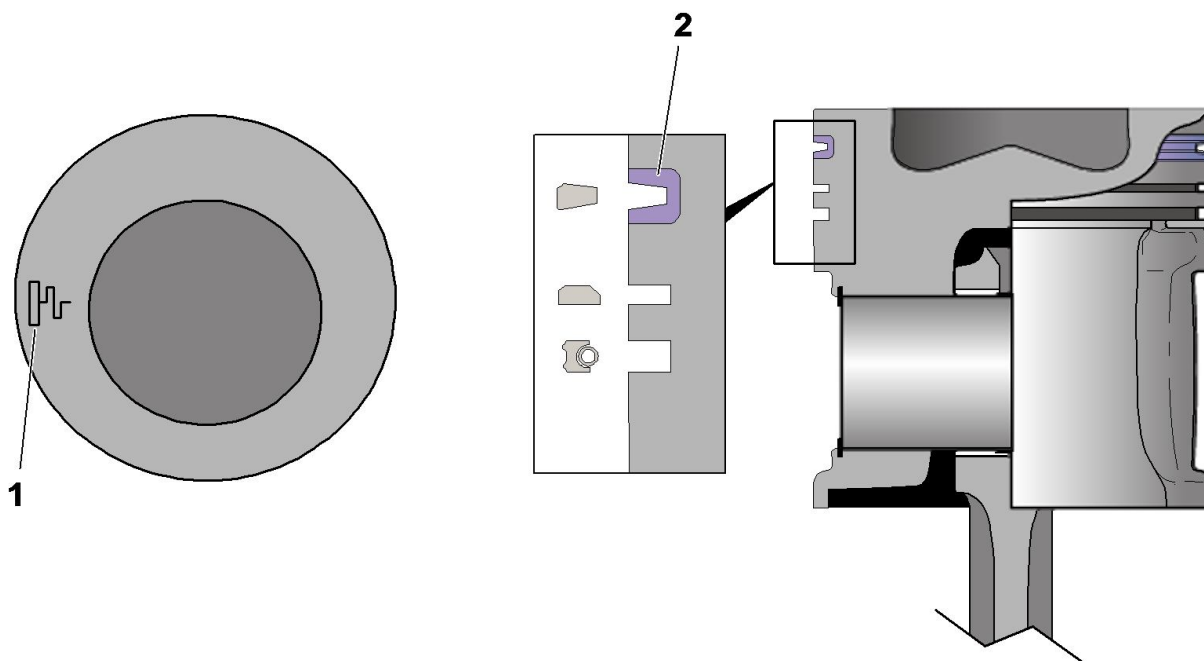

G0007816

Figure 1

1. Flywheel symbol
2. Iron carrier

Document Title: Piston rings, description	Function Group: 213	Information Type: Service Information	Date: 2014/10/11
Profile: EXC, EC290B FX [GB]			

Piston rings, description

Each piston is equipped with two compression rings and one oil ring. The uppermost compression ring is of the "Keystone" type (dual trapezoid-formed cross section). Compressions rings should be placed with the text facing upwards.

The oil ring is equipped with two scraping edges, which are pressed against the cylinder wall using the spring tension in the ring and an expander spring placed on the inside of the ring. The oil ring can be placed on either side but should be placed with expander spring and oil ring openings 180° from one another.

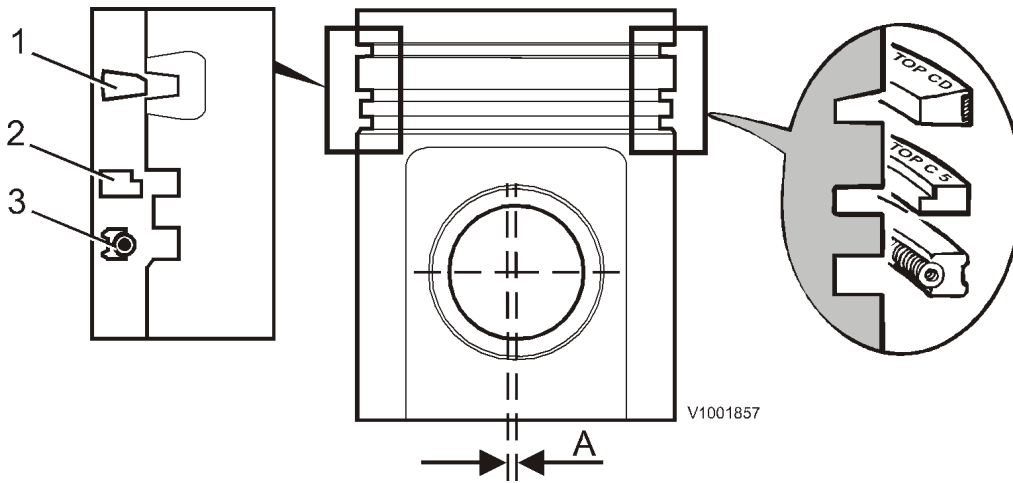
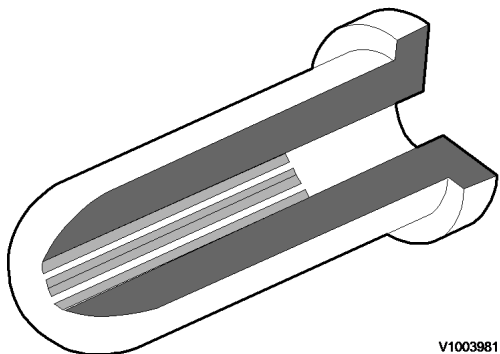

Figure 1

Document Title: Piston cooling	Function Group: 213	Information Type: Service Information	Date: 2014/10/11
Profile: EXC, EC290B FX [GB]			

Piston cooling



V1003981

Figure 1
Piston cooling

The piston is cooled by spraying lube oil against the inside of the piston top.

The 2-hole piston cooling nozzles made of plastic are fitted in the main bearing pedestals.

Buy Now



Our support email:

ebooklibonline@outlook.com