

Document Title: Engine, description	Function Group: 200	Information Type: Service Information	Date: 2014/7/10
Profile: EXC, EC340D L [GB]			

Engine, description

Engines D11H, D13H, and D16H are straight six-cylinder, four-stroke, direct-injected diesel engines. They are equipped with a single variable geometry turbocharger (VGT) and feature cooled external exhaust gas recirculation (EGR). They have charge-air cooling with mechanically actuated electronically controlled unit injectors, controlled by the EMS-system.

The engines have a one-piece cylinder head with four valves per cylinder and a single overhead camshaft. Rear-mounted timing gear results in a shorter engine and lighter drivetrain installation. The engine brake for articulated haulers, VEB7, does not have the additional Exhaust Pressure Governor, EPG. Sufficient exhaust back-pressure will be controlled via the VGT.

For more information, see:

- [220 Lubrication system, description](#)
- [230 Fuel system, description](#)
- [250 Inlet and exhaust system, description](#)
- [254 Exhaust Aftertreatment System, description](#)
- [255 Turbocharger, description](#)
- [260 Cooling system, description](#)
- [293 Exhaust Gas Recirculation \(EGR\), description](#)

For Articulated Haulers:

- [253 Auxiliary brake \(engine braking\), description](#)

The cylinders are numbered in sequence, starting farthest from the flywheel. Ignition order: 1-5-3-6-2-4. The engine's rotational direction is counter-clockwise, seen from the flywheel.

Engine identification

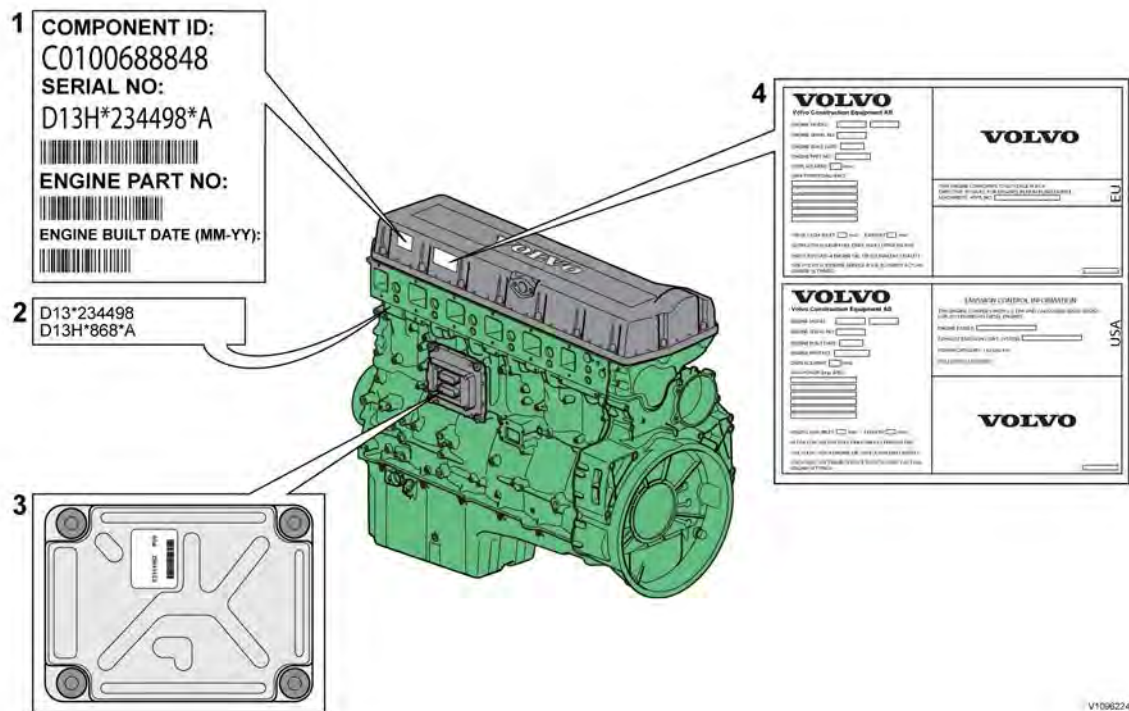

Figure 1
Identification plates, D13H

Identification plate 1

A label located on the valve cover showing the engine's component ID-number, serial number, manufacturing site, engine part number, and engine build date, as well as their bar codes. Manufacturing sites:

- A = Skövde, Sweden
- E = Curitiba, Brazil
- F = Flen, Sweden
- L = Lyon, France

Identification plate 2

The engine's serial number, part number, and manufacturing site are stamped into the engine's cylinder block.

Identification plate 3

The hardware component number of the Engine Control Unit (ECU) is located on a label on the back of the ECU.

Identification plate 4

The certification label is located on the valve cover as well as the machine's frame.

Automatic Engine Shutdown

This is a function used to automatically shut down the engine after idling for a certain time. The operator is informed and has the opportunity to cancel the function within one minute, either by increasing the engine speed, shifting gear, or by activating the hand throttle.

Engine protection

The ECU contains functionality designed to protect the engine from damage during extreme operating conditions or from further damage when an essential engine component fails. There are several proactive functions, and different applications have different functions activated. The ones that can be activated are:

- High coolant temperature

- High intake manifold air pressure
- High intake manifold air temperature
- High oil temperature
- Low oil pressure
- Low coolant level
- High temperature of cooled EGR exhausts after the EGR-cooler
- High crankcase pressure
- Variable Geometry Turbo valve and position error
- High temperature of Smart Remote Actuator
- High compressor charge-air temperature (calculated)
- High soot load
- High differential pressure across Diesel Particulate Filter (DPF)
- High exhaust temperature
- High ECU temperature
- High DPF temperature

Various protective actions such as warning lights, engine torque reduction, engine speed limitation, and vehicle speed limitation may be taken when the above functions reach dangerous levels that may damage the engine. In order to always allow the operator to move a machine away from an unsafe situation, there is a delay of at least 30 seconds before the protective actions (such as forced idle and forced shutdown) are activated after a Key-ON. If the engine has been forced to shutdown or forced to idle due to an active engine protection function, the operator can obtain a 30 second delay by powering down the EMS with a Key-OFF for 7 seconds and then a Key-ON (the EMS is powered down by the Vehicle-ECU (V-ECU) after the ignition key has been in its OFF position for approx. 7 seconds). In addition to the above protective functions, other software functions could request engine protection, such as:

- High Altitude (ensures that high compressor charge-air temperature is never reached)
- Turbo OverSpeed
- Low Coolant Temp
- Crank Sensor Failure
- Gear Ratio
- Regeneration

Warning lights

There are two levels for warning lights, an amber caution light and a red stop light.

- The **amber light** indicates a warning situation
- The **red light** indicates that the vehicle must be stopped.

Engine torque limitation

The engine torque can be limited by the engine protection function. Engine torque limitation is active until the parameter has reached a safe level or until the EMS is powered down.

Forced Idle

The engine can be forced to idle speed by the engine protection function. Forced idle is active until conditions triggering the problem are back within normal working range or the EMS is powered down.

Engine Shutdown

The engine can be forced to shut down after conditions have reached levels that may cause engine failure and the machine speed is below a specified value.

Machine Speed and Engine Speed Limits

The engine protection function can limit the speed of the vehicle and/or the engine's rpm.

Levels of engine protection

Available proactive functions depend not only on the application but also on what level of protection has been activated for the specific machine. Two levels of engine protection are offered, the standard level is Basic protection and the optional level Extended protection. The general difference between basic and extended engine protection is that no active actions such as forced idle and forced shutdown will be taken in basic engine protection (with the exception of crankcase pressure that can cause shutdown in either setup). Warnings will be given to the operator regardless of engine protection level.

Parameters

- (FAU) Automatic engine shut off
- (FAV) Automatic engine shut off, time

- (JVL) Injector cylinder 1, calibration E3 Glitch Trim
- (JVM) Injector cylinder 2, calibration E3 Glitch Trim
- (JVN) Injector cylinder 3, calibration E3 Glitch Trim
- (JVO) Injector cylinder 4, calibration E3 Glitch Trim
- (JVP) Injector cylinder 5, calibration E3 Glitch Trim
- (JVQ) Injector cylinder 6, calibration E3 Glitch Trim
- (YA) Idle speed, setting

Supplementary information

- [200 Component locations](#)

Function check

- 17030-3 Parameter, programming

Diagnostics

Detailed information about the following relevant warnings and error codes is available under the diagnostics tab.

Component	Control unit	Message ID
EF2112 (ART) PID404 (EXC, WLO)	MID128	PID404
EF2117 (ART) PPID55 (WLO, EXC)	MID128	PPID55
EF2127 (ART) PPID89 (EXC, WLO)	MID128	PPID89
EF2515 (ART) PSID28 (WLO, EXC)	MID128	PSID28
EF2525 (ART) PID173 (EXC) SE2510 (WLO)	MID128	PID173
SE2202 FX1006 (WLO)	MID128	PID175
SE2507 FX1007 (WLO)	MID128	PID105
MO2501	MID128	SID27
PPID326 (WLO, EXC)	MID128	PPID326
SE2203	MID128	PID100
SE2509	MID128	PID153
SE2516	MID128	PID412
SE2519	MID128	PID81
SE2603	MID128	PID111
SE2606	MID128	PID110

Document Title: VCADS Pro, Operations	Function Group: 200	Information Type: Service Information	Date: 2014/7/10
Profile: EXC, EC340D L [GB]			

VCADS Pro, Operations

The following VCADS Pro operations are available for function group 2. Operations used when changing or working on components are mandatory.

Tests

Operation	Application
20046-3 Read out engine information	The operation is used to read out the engine emission and engine certificate information when requested by the customer or other interested parties.
21006-3 Cylinder compression, test	Used when there is a suspicion of fault and/or at abnormal values/readings. This test indicates if there is any deviation in compression in any cylinder in relation to the other cylinders. As a first check this operation is both easy and fast to perform instead of a real compression test.
23016-3 Cylinder balancing, test	Used when there is a suspicion of fault and/or at abnormal values/readings This test indicates whether any of the injectors deviates too much in the fuel injection so that the engine characteristics are damaged.
23017-3 Feed pressure, inspection	Used when there is a suspicion of fault and/or at abnormal values/readings.
23712-3 Injectors shut off, manual	Used when there is a suspicion of fault and/or at abnormal values/readings.
25410-3 Air pump exhaust aftertreatment, test	Used when there is a suspicion of fault and/or at abnormal values/readings.
25411-3 Burner exhaust aftertreatment, test	Used when there is a suspicion of fault and/or at abnormal values/readings.
25412-3 Components ASU, test	With this sub-test, the functions of the atomiser air valve, the main air valve, the fuel shut-off valve and the fuel pump are checked.
25433-3 Fuel system exhaust aftertreatment, bleeding	Used when there is a problem with the tension on the spring in the fuel pressure regulator in the atomization.
25434-3 Atomization unit, fuel pressure, adjust	Used when there is a problem with the tension on the spring in the fuel pressure regulator in the atomization.
25436-3 Atomization unit, air pressure, adjust	Used when there is a problem with the tension on the spring in the fuel pressure regulator in the atomization.
25456-3 Exhaust aftertreatment diagnostics	Used when there is a suspicion of fault and/or at abnormal values/readings.
25457-3 Diesel Particulate Filter Service Regeneration	Used when the soot load is over 1.7. See 254 Exhaust Aftertreatment System, description Before starting service regeneration check the differential pressure over the diesel particle filter so that it is within stated value according to the service information. This is to make sure that the DPF won't get damaged by the service regeneration. After the service regeneration and when the exhaust temperature has stabilized to a normal level check the differential pressure over the DPF again so that it is within stated value according to the service information. This is to determine that the filter has been

regenerated correctly and that it is not clogged with ash.

25460-3 Reset soot and ash load	When the diesel particulate filter has been changed, the soot load and the ash load must be reset. The reset is needed to indicate to the system that the filter has been cleaned. The soot load and ash load must only be reset if a clean filter has been installed.
25537-3 Variable geometry turbo function test	Used when there is a suspicion of fault and/or at abnormal values/readings.
27502-3 Engine speed control, test	Used when there is a suspicion of fault and/or at abnormal values/readings.
28407-3 Sensor values, monitoring	Used when there is a suspicion of fault and/or at abnormal values/readings.
28420-3 Flywheel and camshaft signal, test	Used when there is suspicious of faulty signals or faulty connected sensor.
29332-3 Exhaust gas circulation, function test	Used when there is a suspicion of fault and/or at abnormal values/readings.

Calibrations

Operation	Application
25536-3 Variable geometry turbo, calibration	When changing actuator. See 255 Actuator, variable turbocharger, replacing

Programming

Operation	Application
25801-3 MID 233 Control unit, programming	When changing ACM or only reprogramming. See 254 ACM, replacing, non-programmed
25802-3 MID 233 Control unit, campaign	
28423-3 MID 128 ECU, programming	When changing ECU or only reprogramming. See 200 E-ECU, MID 128, changing non-programmed ECU .
28422-3 MID 128 ECU, campaign	

Document Title: Engine, identification	Function Group: 200	Information Type: Service Information	Date: 2014/7/10
Profile: EXC, EC340D L [GB]			

Engine, identification

Identification plate 1

A decal with the software's ID-number, the engine's serial number and assembly plant is located on the valve cover to ensure installation of correct ECU on the engine in production. On the back of the ECU, there is a decal indicating its hardware number.

Identification plate 2

Engine designation, serial number, part number and assembly plant are stamped in one field on the engine block's left front edge.

Assembly plants:

A = Skövde, Sweden

E = Curitiba, Brazil

F = Flen, Sweden

L = Lyon, France

Identification plate 3

The engine control unit (ECU) has its component number on a plate on the back.

Identification plate 4

The certification decal is located on the valve cover as well as on the left side of the machine's front frame.

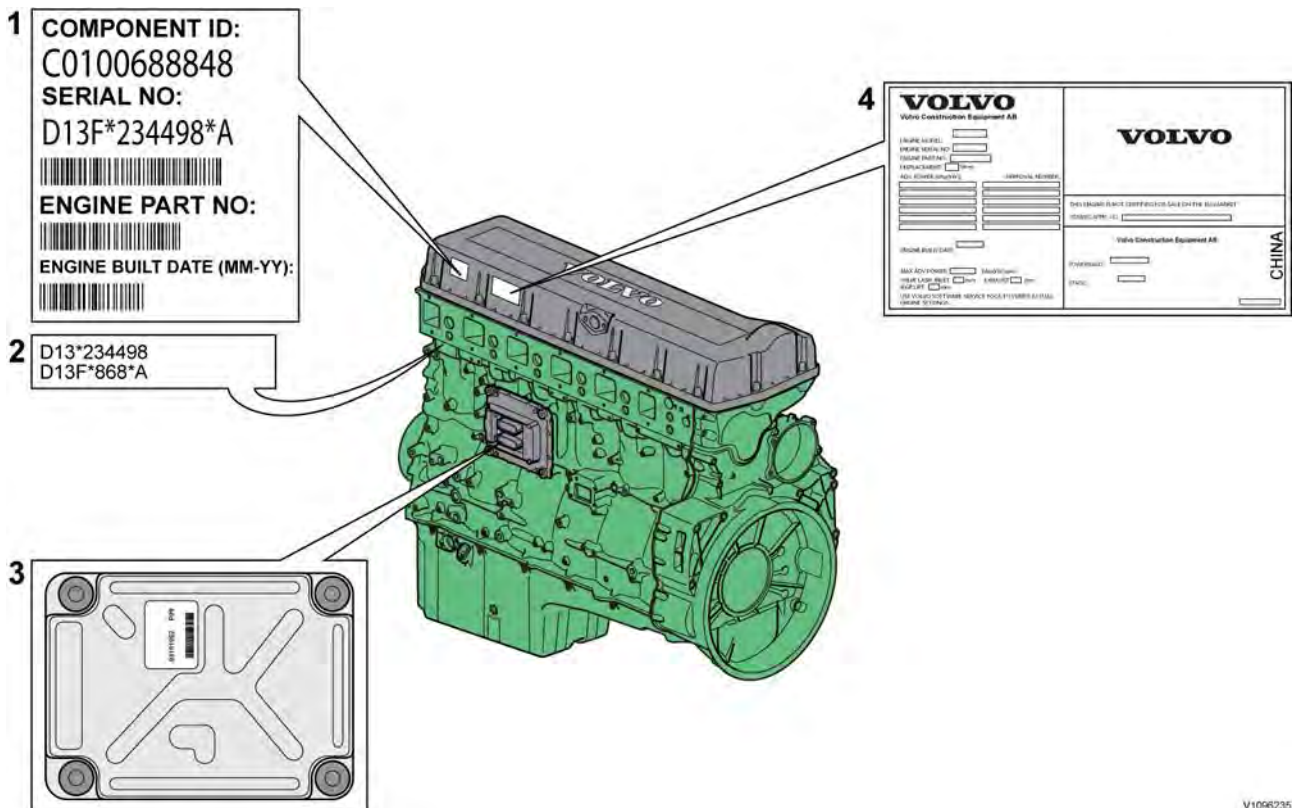

Figure 1

Document Title: Component locations	Function Group: 200	Information Type: Service Information	Date: 2014/7/10
Profile: EXC, EC340D L [GB]			

Component locations

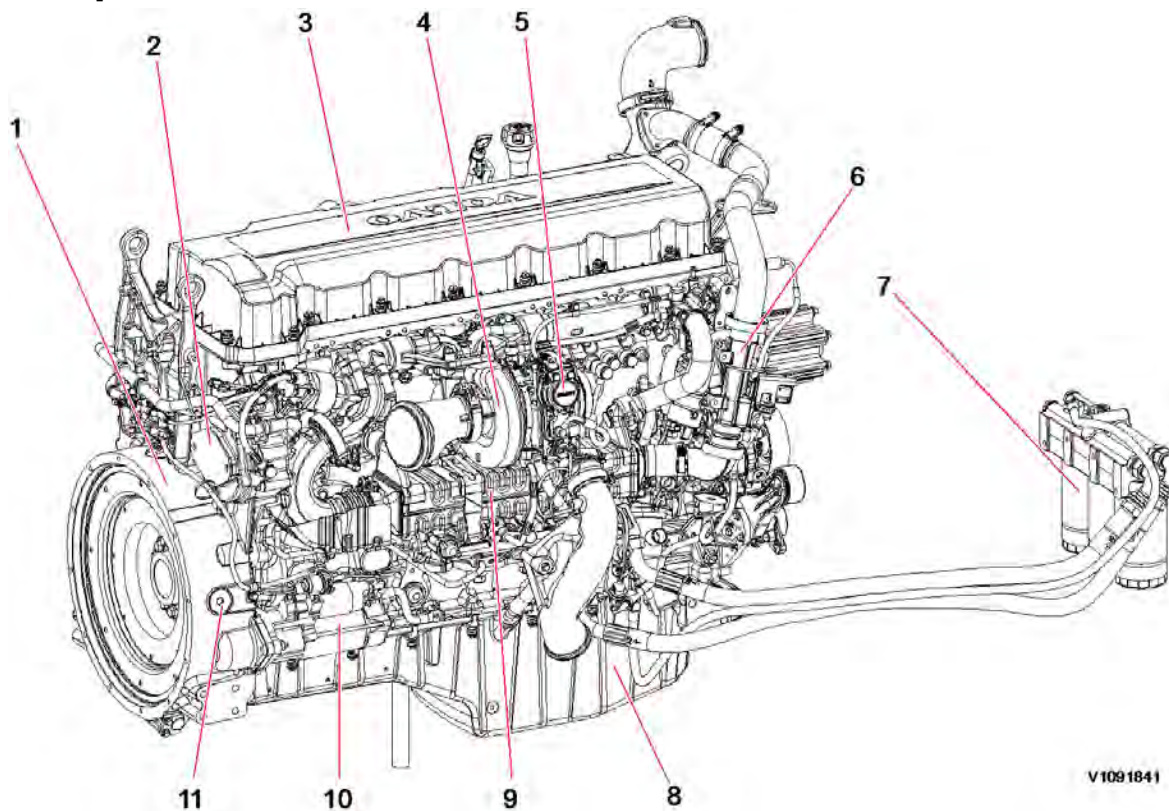
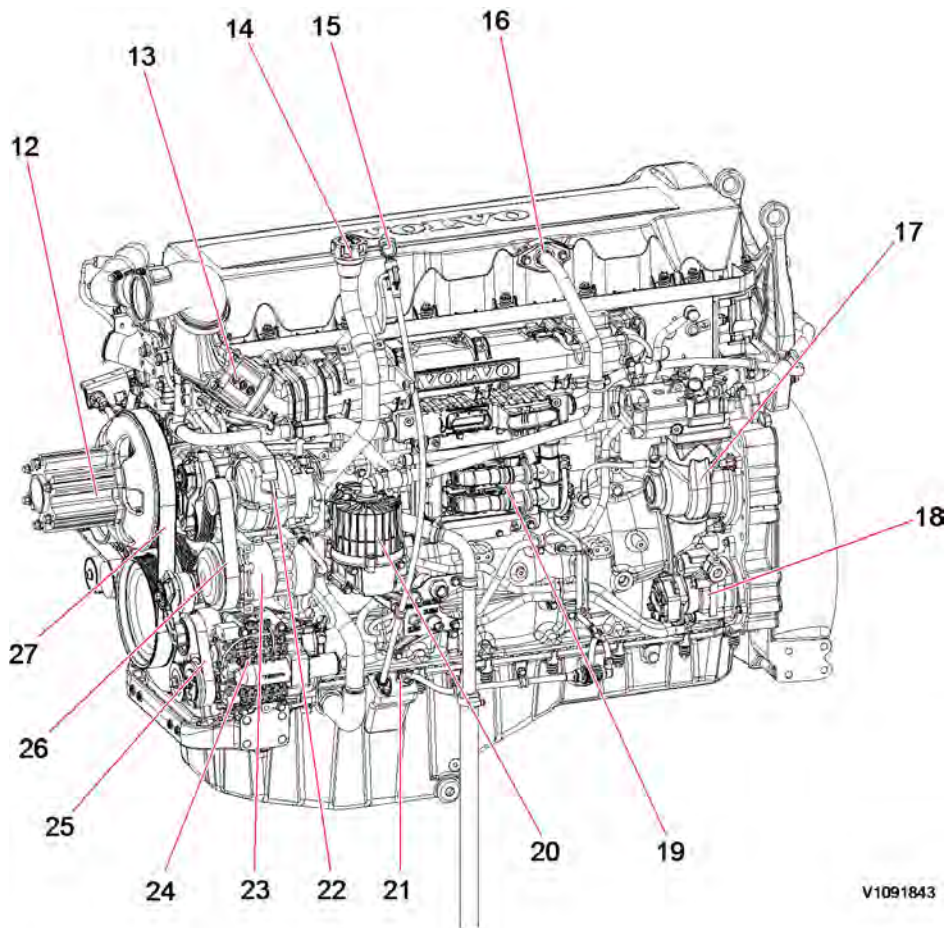

Figure 1
Engine, front side

1	Flywheel housing	7	Engine oil filter
2	P.T.O (Power Take Off) port	8	Oil pan
3	Valve cover	9	EGR cooler
4	Turbocharger	10	Starter motor
5	Turbocharger actuator	11	TDC mark checking port
6	Venturi pipe		



V1091843

Figure 2
Engine, back side

12	Fan pulley	20	Crankcase ventilation separator
13	Pre-heating coil	21	Oil level sensor
14	Engine oil filling port	22	Alternator
15	Dipstick gauge	23	Air conditioner compressor
16	Crankcase ventilation tube	24	Air pump
17	Air compressor	25	Air pump belt
18	Fuel feed pump	26	Alternator/Compressor belt
19	E-ECU	27	Fan belt

Document Title: E-ECU, MID 128, changing non-programmed ECU	Function Group: 200	Information Type: Service Information	Date: 2014/7/10
Profile: EXC, EC340D L [GB]			

E-ECU, MID 128, changing non-programmed ECU

Op nbr 200-068

1. Park the machine in the service position A, see [091 Service positions](#).
2. Connect the VCADS Pro computer to the machine, and perform operation '28423-3 MID 128 control unit, programming'.
3. When VCADS Pro 'MID 128 ECU, programming' window appears, follow the instructions for replacing E-ECU.
4. Turn OFF battery disconnect switch.
5. Remove the engine hood rear cover screws.

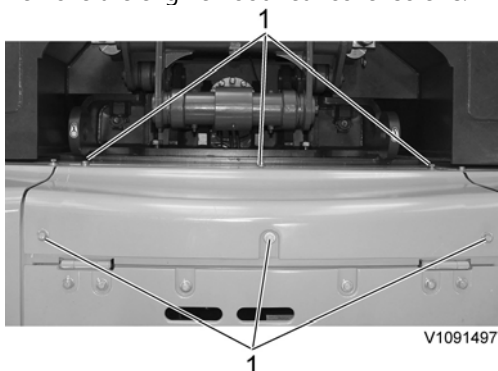

Figure 1

1. Screws

6. Remove the bracket.

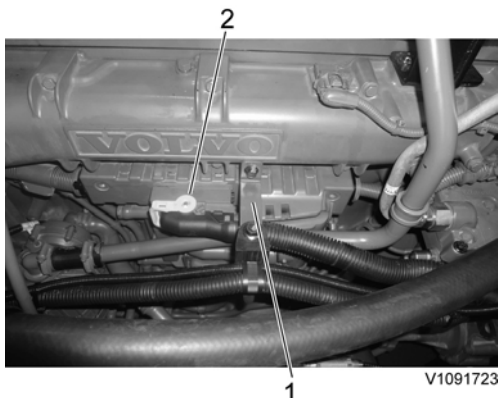

Figure 2

1. Bracket

2. CNEI connector
7. Disconnect the CNEI connector.
8. Remove the air hose.

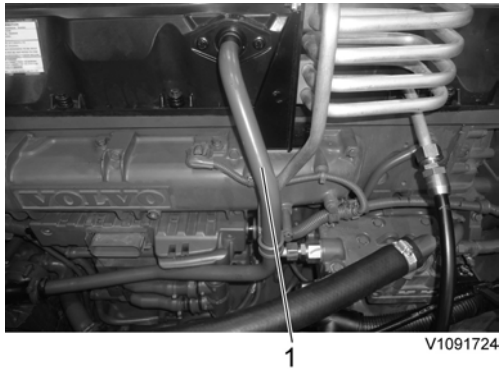

Figure 3

9. Remove screws from wire harness clamps, and disconnect the wiring harness connectors from E-ECU.

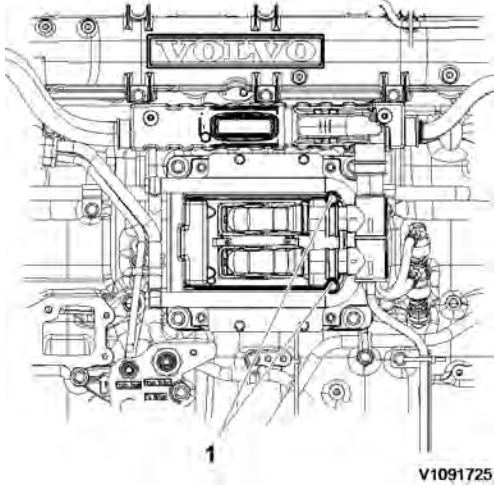

Figure 4

1. Screws
10. Remove screws fixing the fuel pipe and E-ECU.

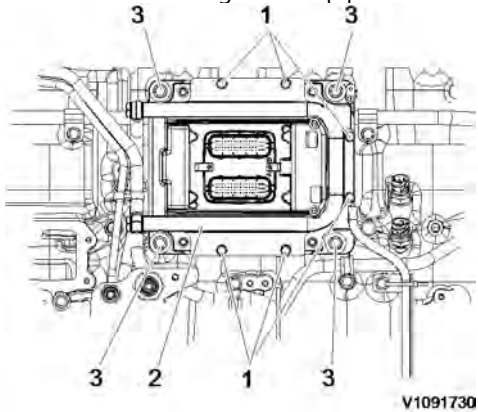

Figure 5

1. Screw

2. Pipe
3. Screw

Put the fuel pipe away.

11. Remove 4 screws fixing the E-ECU and replace the E-ECU.
12. Install fuel pipe and screws.
Connect wire harness connectors to the E-ECU, and install wire harness clamp screws.
13. Install the air hose and bracket.
14. Install the engine hood rear cover, and the screws.
15. After replacing E-ECU, press OK button of VCADS Pro operation '28423-3 MID 128 control unit, programming'.
Now VCADS Pro starts the programming of software and parameters to the new E-ECU.
16. Start the machine and check that no error messages appear.

Document Title: E-ECU, MID 128, changing pre-programmed ECU	Function Group: 200	Information Type: Service Information	Date: 2014/7/10
Profile: EXC, EC340D L [GB]			

E-ECU, MID 128, changing pre-programmed ECU

Op nbr 200-070

1. Park the machine in the service position A, see [091 Service positions](#).
2. Connect VCADS Pro computer to the machine, and perform operation '17030-2 Parameter, programming'.
3. Use the function 'save all parameters to job card'.
4. Turn OFF battery disconnect switch.
5. Remove the engine hood rear cover screws.

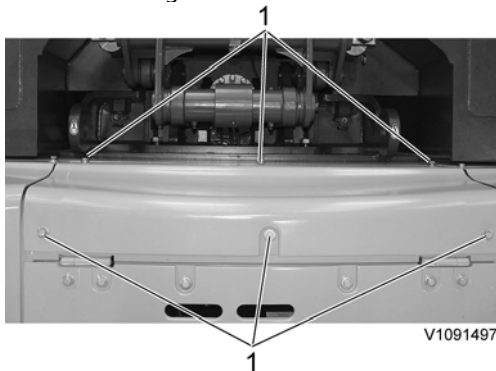

Figure 1

1. Screws

6. Remove the bracket.

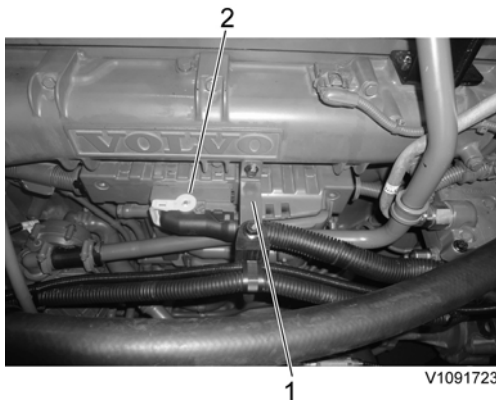

Figure 2

1. Bracket
2. CNEI connector

7. Disconnect the CNEI connector.

8. Remove the air hose.

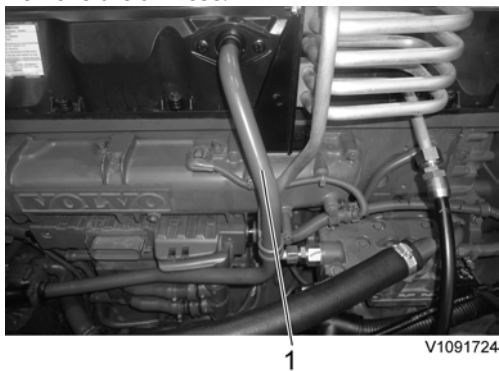

Figure 3

1. Hose

9. Remove screws from wire harness clamps, and disconnect the wire harness connectors from E-ECU.

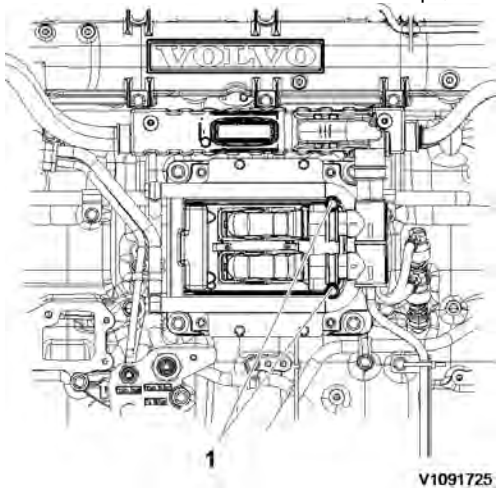

Figure 4

1. Screw

10. Remove screws fixing the fuel pipe and E-ECU. Put the fuel pipe away.

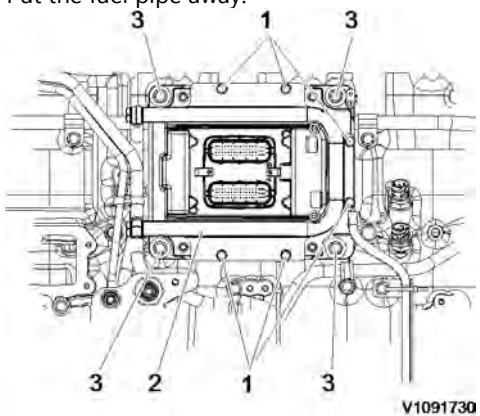

Figure 5

Buy Now



Our support email:

ebooklibonline@outlook.com