

Document Title: <b>Engine, description</b>	Function Group: <b>200</b>	Information Type: <b>Service Information</b>	Date: <b>2015/2/13</b>
Profile: <b>EXC, EC360C NL [GB]</b>			

## Engine, description

- The D12D is the model number of the Volvo 12 liter engine.
- The engine is a 6-cylinder, 4-stroke, direct injection diesel with a 12 liter cylinder volume, turbocharger, charge air cooler and electronic controlled fuel injection, EMS (Engine Management System).
- The serial number of the engine is to be found stamped in the cylinder block on the rear left side.
- The cylinder head is of cast iron and manufactured in one piece which is necessary in order to provide stable bearings for the overhead camshaft.
- The cylinder liner is sealed against the coolant casing with rubber rings.
- The D12D has a four-valve system and overhead camshaft.
- The engine timing gear transmission is located at the front of the engine on a 10 mm thick steel plate bolted to the cylinder block.
- The crankshaft is drop forged and has induction hardened bearing surfaces and fillets.
- The engine is force fed lubricated by an oil pump which is gear driven from the engine crankshaft via an intermediate gear
- The fuel system for D12D has electronic control with unit injectors one for each cylinder and which operate at a very high pressure.
- The fuel feed pump is a gear driven type and is driven from the engine timing gear with the same gear.

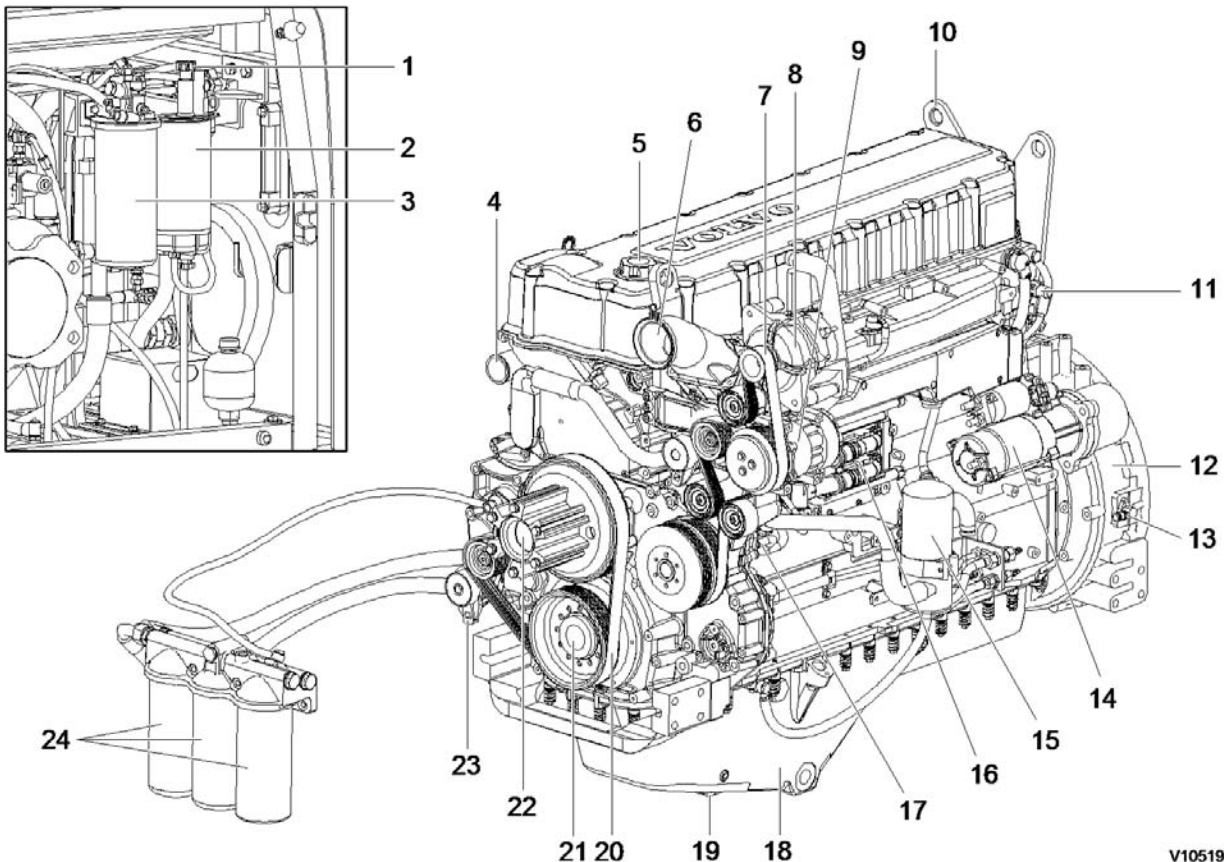

V1051975

**Figure 1**  
**Engine, structure**

1	Hand pump	9	Air conditioner compressor	17	Fuel feed pump
2	Water separator	10	Lifting bracket	18	Oil pan
3	Fuel filter	11	Coolant temperature sensor	19	Engine oil drain valve
4	From radiator	12	Flywheel housing	20	Fan belt
5	Engine oil filler	13	Speed sensor	21	Crankshaft pulley
6	From charge air cooler	14	Starter motor	22	Fan drive and pulley
7	Alternator belt	15	Breather	23	Belt tensioner
8	Alternator	16	E-ECU	24	Engine oil filter

Document Title: <b>Engine, identification</b>	Function Group: <b>200</b>	Information Type: <b>Service Information</b>	Date: <b>2015/2/13</b>
Profile: <b>EXC, EC360C NL [GB]</b>			

## Engine, identification

### Identification plate

The engine model, serial number and performance data are stamped on an identification plate which is attached on the cylinder head cover. The engine model designation and serial number must be indicated when ordering spare parts.

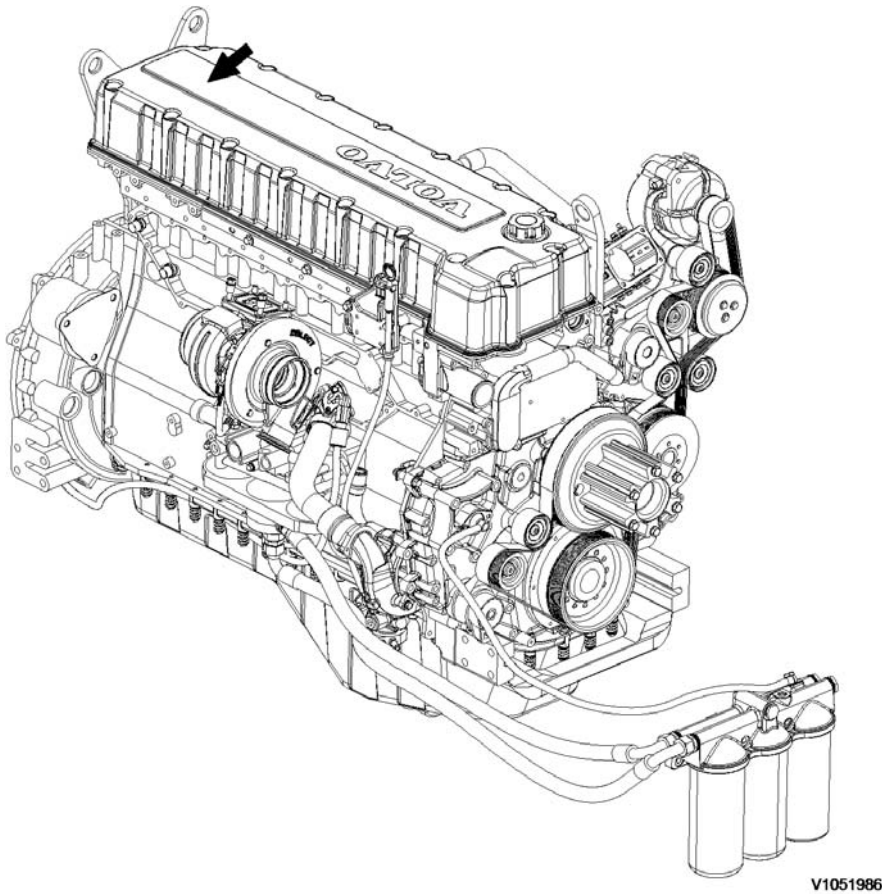

**Figure 1**  
**Engine identification plate location**

Document Title: <b>Engine, removing</b>	Function Group: <b>210</b>	Information Type: <b>Service Information</b>	Date: <b>2015/2/13</b>
Profile: <b>EXC, EC360C NL [GB]</b>			

## Engine, removing

Op nbr 210-070

[9998257 Lifting tool](#)

[9998547 Lifting device](#)

### **WARNING**

**Risk of burns - stop the diesel engine and allow it to cool down before starting any work.**

### **WARNING**

**Removal of residual pressure from the circuit must be done prior to any maintenance.**

#### **NOTE!**

Cable ties and clamps that secure hoses and electrical wiring must be removed and then replaced when installing.

1. Place the machine in the service position B. See [091 Service positions](#)
2. Turn off the battery disconnect switch.
3. Loosen two screws and connect hose (1), and then drain the hydraulic oil into a suitable collection container.

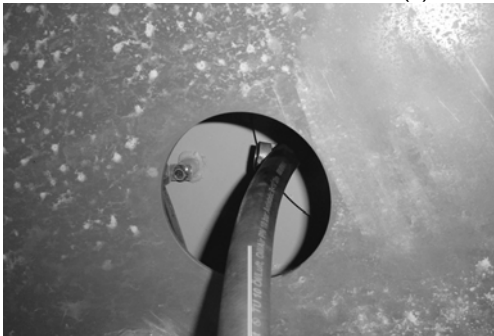

V1043812

1

**Figure 1**  
**Hydraulic oil tank, drain**

4. Drain the coolant in a collection container.
5. Remove under cover (1).

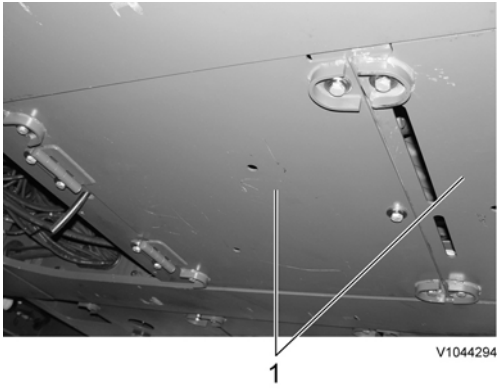

**Figure 2**  
**Removal, under cover**

6. Remove silencer hood (1).



**Figure 3**  
**Removal, silencer hood**

7. Remove screws (1) and open radiator hood (2).

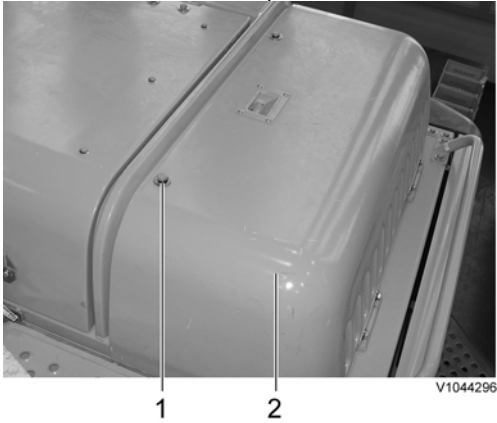

**Figure 4**  
**Opening, radiator hood**

8. Remove the rear cover of the engine hood.

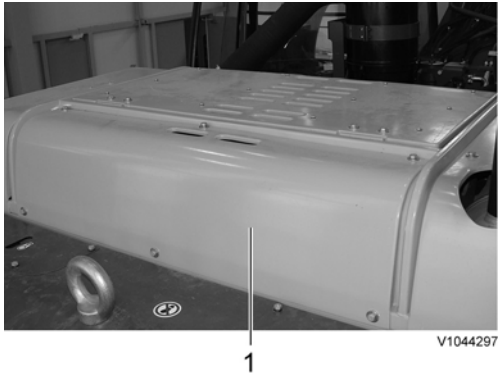

**Figure 5**  
**Removal, cover**

9. Open the engine hood and remove the cowl mounting screws.
10. Remove cowl (1) using a lifting device.
11. Disconnect wire harness connector (2), hoses (3), and remove expansion tank (1) with the bracket.

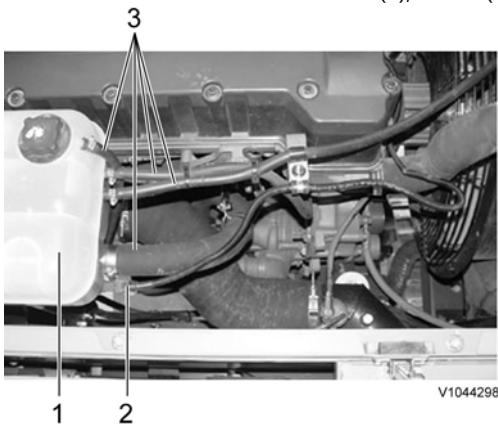

**Figure 6**  
**Removal, expansion tank**

12. Remove foot step (1).

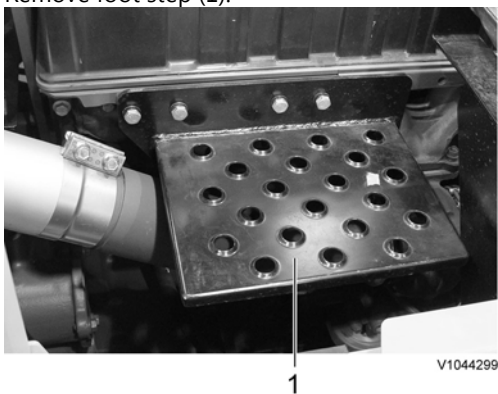

**Figure 7**  
**Removal, step**

13. Disconnect radiator hose (2) and upper charge air cooler hose (1).

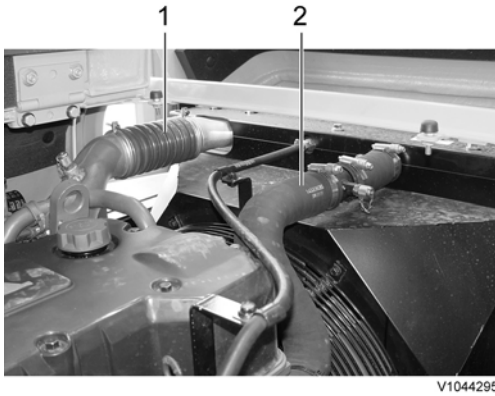

**Figure 8**  
**Removal, radiator and charge air cooler hose**

14. Disconnect hose (1) of engine oil remote filter bypass.



**Figure 9**  
**Disconnect, hose**

15. Remove radiator fan guard (1).

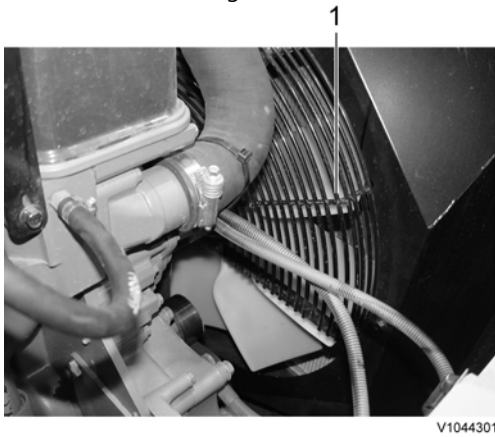

**Figure 10**  
**Removal, radiator fan guard**

16. Remove radiator fan (1).

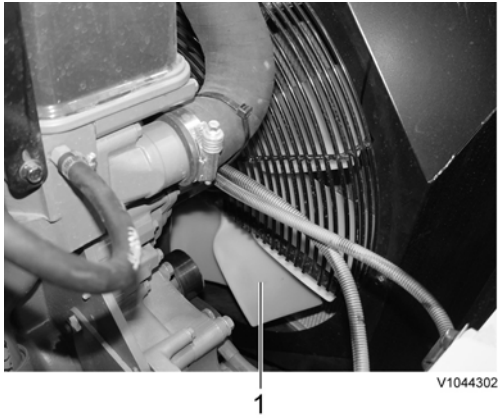

**Figure 11**  
**Removal, radiator fan**

17. Disconnect turbocharger inlet hose (1).

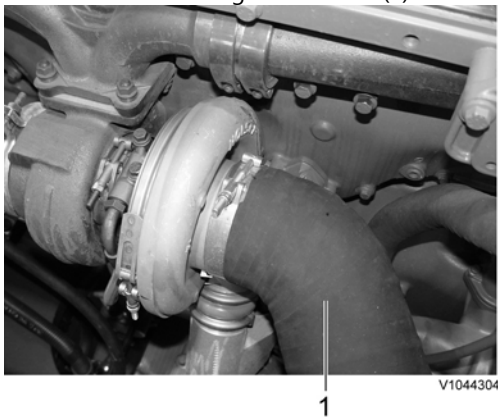

**Figure 12**  
**Disconnect, hose**

18. Disconnect cab heater hoses on the engine block and coolant pump.

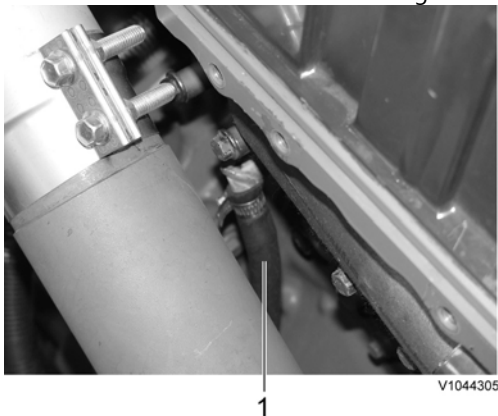

**Figure 13**  
**Disconnect, hose**

1. Cab heater hose on engine block

19. Open the machine right side cover.
20. Remove the main pump. See [913 Hydraulic pump, replacing](#)
21. Disconnect the fuel line hoses (4 pcs).  
**NOTE!**



Ports must be plugged after disassembling hoses.

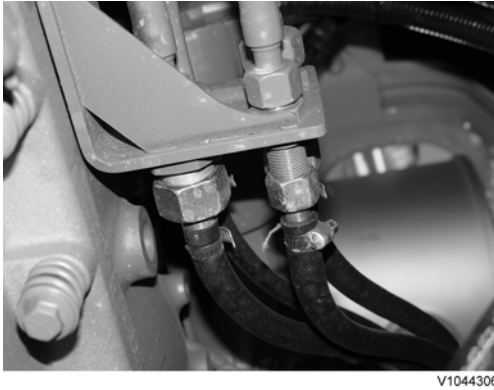

**Figure 14**  
**Disconnect, hose**

22. Remove the pump gearbox coupling. See [442 Pump gearbox coupling assembly, replacing](#).
23. Disconnect starter motor wire harness (1).

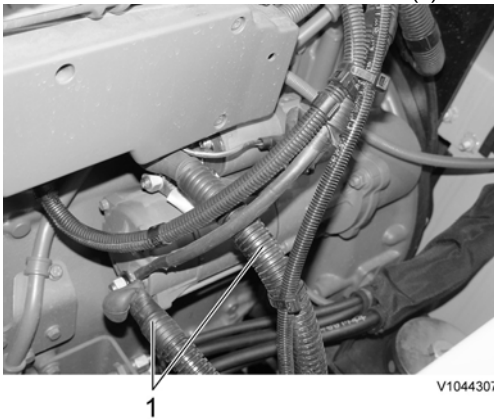

**Figure 15**  
**Removal, wire harness**

24. Disconnect inlet hose (2), outlet hose (1) on the engine PTO pump.

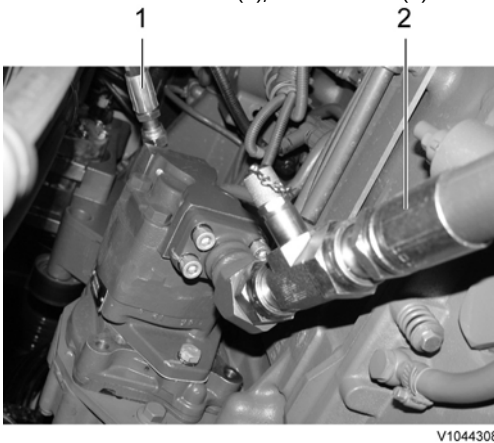
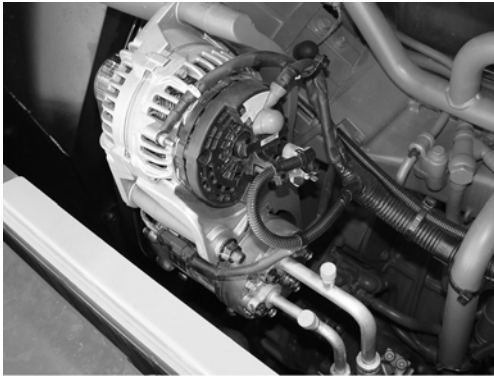

**Figure 16**  
**Removal, inlet and outlet hose**



**Do not disconnect or loosen connections for the air conditioning unit (AC). Risk of gas leakage.**

25. Remove the compressor from the engine.



**Figure 17**  
**Removal, compressor**

26. Disconnect the wire harness for all engine sensors.
27. Remove cover (1) and disconnect main wire harness (2).

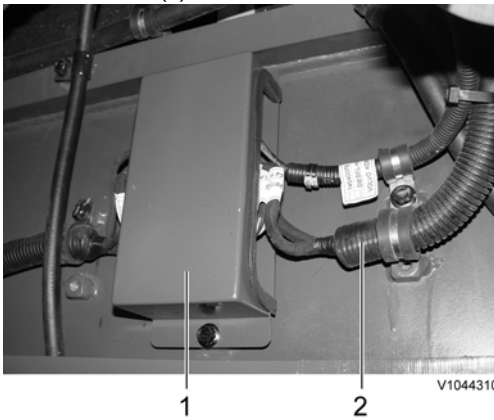

**Figure 18**  
**Removal, cover**

28. Disconnect radiator lower hose (1) and charge air cooler lower hose (2).

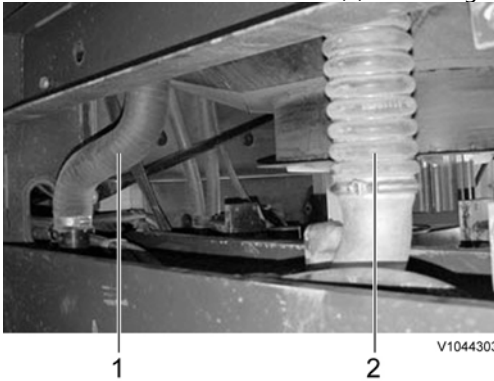

**Figure 19**  
**Disconnect, radiator and charge air cooler hose**

1. Radiator hose
2. Charge air cooler hose

29. Disconnect the engine oil remote hose (1).

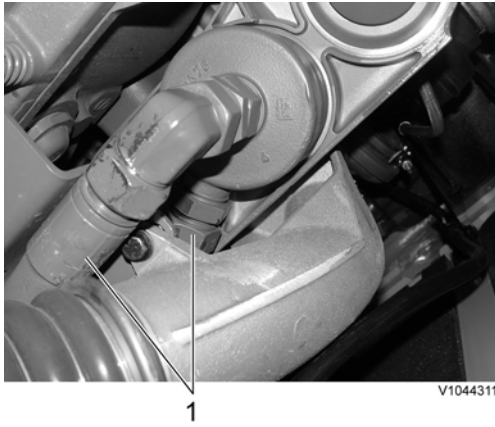

**Figure 20**  
**Disconnect, hose**

30. Remove the engine mounting screws (4 places).

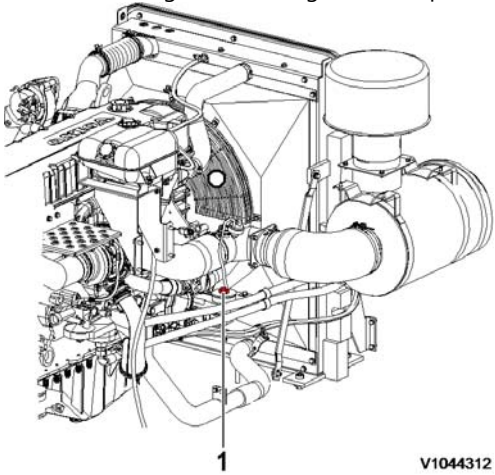

**Figure 21**  
**Removal, mounting screws**



**The parts are heavy. Take appropriate safety precautions.**

31. Fit tool 9998257 and connect 9998547 and a lifting device to the engine and remove the engine slowly.

Document Title: <b>Engine, installing</b>	Function Group: <b>210</b>	Information Type: <b>Service Information</b>	Date: <b>2015/2/13</b>
Profile: <b>EXC, EC360C NL [GB]</b>			

## Engine, installing

Op nbr 210-072

[9998257 Lifting tool](#)

[9998547 Lifting device](#)

### NOTE!

Cable ties and clamps that secure hoses and electrical wiring must be removed and then replaced when installing.



### WARNING

The parts are heavy. Take appropriate safety precautions.

1. Fit tool 9998257 and connect lifting device 9998547 and hoist the engine slowly and install the engine.
2. Install the engine mounting screws (4 places).

### NOTE!

Pay attention to the positioning of the brackets, cushions, and mounting screws (front/rear) when assembling.

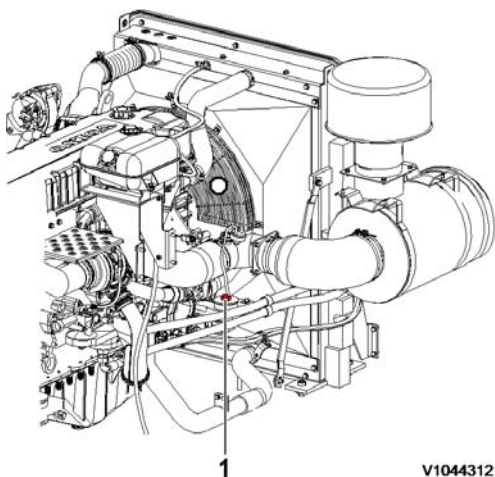

**Figure 1**  
**Installation, engine**

3. Connect engine oil remote hose (1).

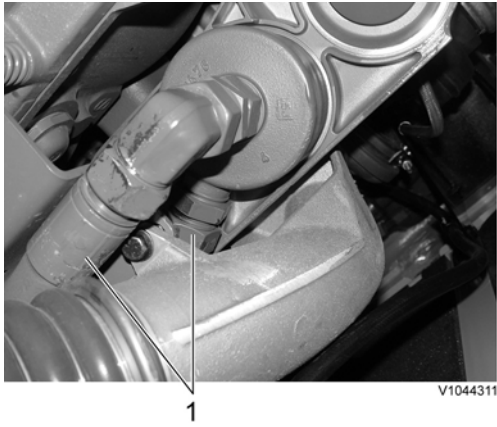

**Figure 2**  
**Connect, hose**

4. Connect radiator lower hose (1) and charge air cooler lower hose (2).

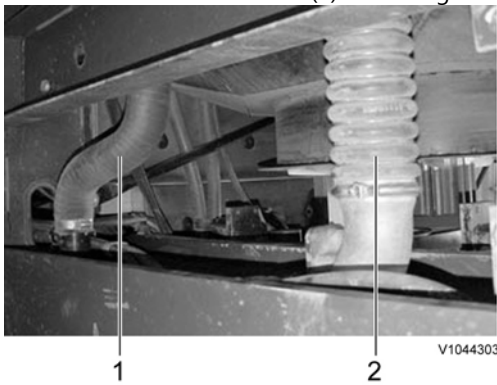

**Figure 3**  
**Connect, hose**

1. Radiator hose
2. Charge air cooler hose

5. Install cover (1) and connect main wire harness (2).

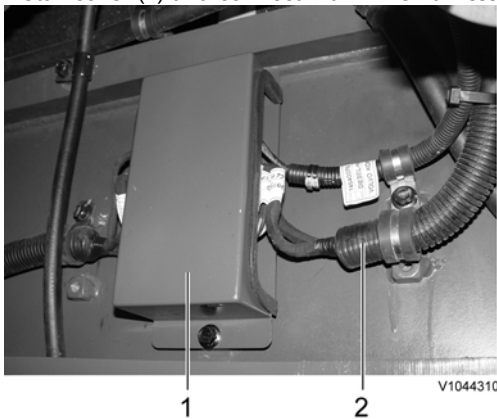

**Figure 4**  
**Installation, wire harness and cover**

6. Connect wire harness for all sensors to the engine.
7. Install the compressor to the engine.

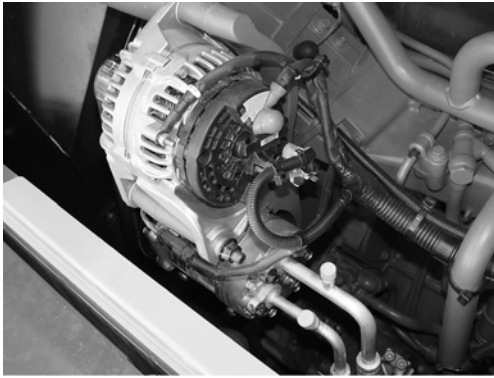

V1044309

**Figure 5**  
**Installation, compressor**

8. Connect inlet hose (2) and outlet hose (1) of the engine PTO pump.

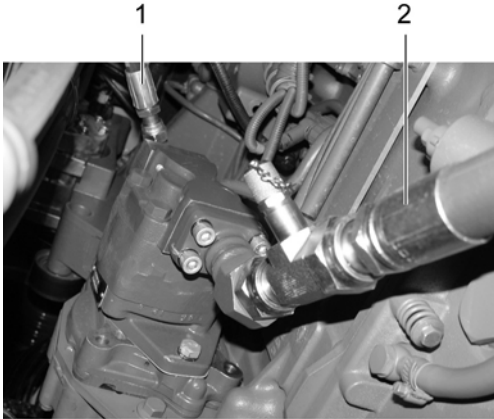

V1044308

**Figure 6**  
**Connect, hose**

9. Connect wire harness (1) to the starter motor.

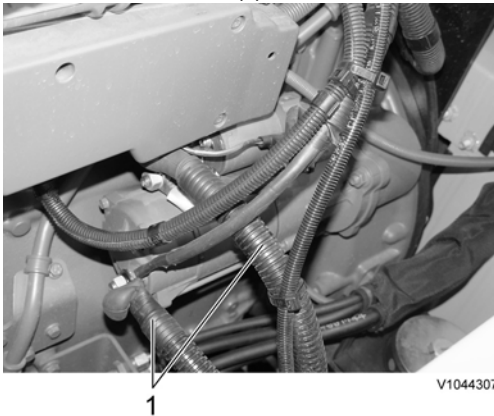

V1044307

**Figure 7**  
**Connect, wire harness**

10. Connect the fuel line hoses (4 pcs).

**Buy Now**



Our support email:

[ebooklibonline@outlook.com](mailto:ebooklibonline@outlook.com)