

| | | | |
|-----------------------------------------------|-------------------------------|-------------------------------------------------|----------------------------|
| Document Title: Engine, description | Function Group: 200 | Information Type: Service Information | Date: 2014/4/6 0 |
| Profile: CEX, ECR48C [GB] | | | |

[Go back to Index Page](#)

Engine, description

The engine is a vertical, water-cooled, in-line, four-cylinder, four-stroke diesel with direct injection. It is a low emission engine to American EPA Guideline Stage II and European Directive 97/68/EC Class IIIA with automatic idle.

The engine serial number is stamped on the name plate, on the top of the valve cover. The engine model designation and serial number must be indicated when ordering spare parts.

The direction of rotation viewed from the flywheel is anticlockwise. Ignition sequence: 1-3-4-2 (cylinder no. 1 on flywheel side).

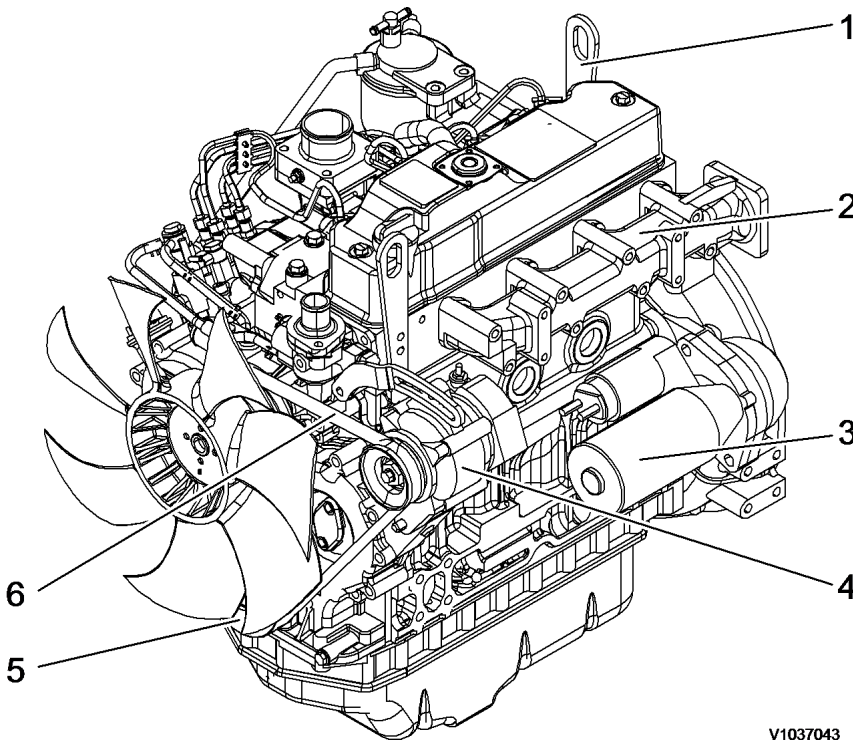

V1037043

Figure 1
Engine, front view

| | | | | | |
|---|------------------|---|---------------|---|---------------------|
| 1 | Lifting eye | 3 | Starter motor | 5 | Crankshaft V-pulley |
| 2 | Exhaust manifold | 4 | Alternator | 6 | V-belt |

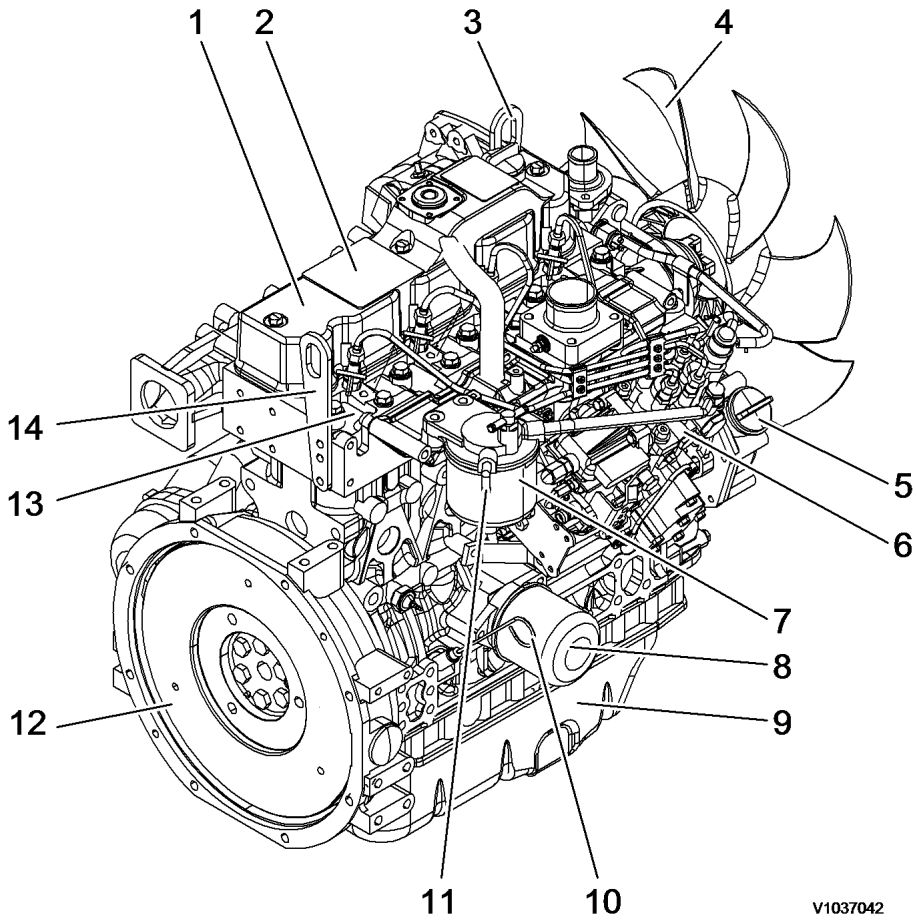

V1037042

Figure 2
Engine, rear view

| | | | | | |
|---|-------------------|----|----------------|----|-----------------|
| 1 | Rocker arm cover | 6 | Injection pump | 11 | Fuel oil inlet |
| 2 | Engine name plate | 7 | Fuel filter | 12 | Flywheel |
| 3 | Lifting eye | 8 | Oil filter | 13 | Intake manifold |
| 4 | Fan | 9 | Oil pan | 14 | Lifting eye |
| 5 | Oil filler port | 10 | Dipstick gauge | | |

| | | | |
|-----------------------------------------------|-------------------------------|-------------------------------------------------|----------------------------|
| Document Title: Engine, description | Function Group: 200 | Information Type: Service Information | Date: 2014/4/6 0 |
| Profile: CEX, ECR48C [GB] | | | |

[Go back to Index Page](#)

Engine, description

The engine is a vertical, water-cooled, in-line, four-cylinder, four-stroke diesel with direct injection. It is a low emission engine to American EPA Guideline Stage interim Tier IV and European Directive 97/68/EC Class IIIA with automatic idle.

The engine serial number is stamped on the name plate, on the top of the valve cover. The engine model designation and serial number must be indicated when ordering spare parts.

The direction of rotation viewed from the flywheel is anticlockwise. Ignition sequence: 1-3-4-2 (cylinder no. 1 on flywheel side).

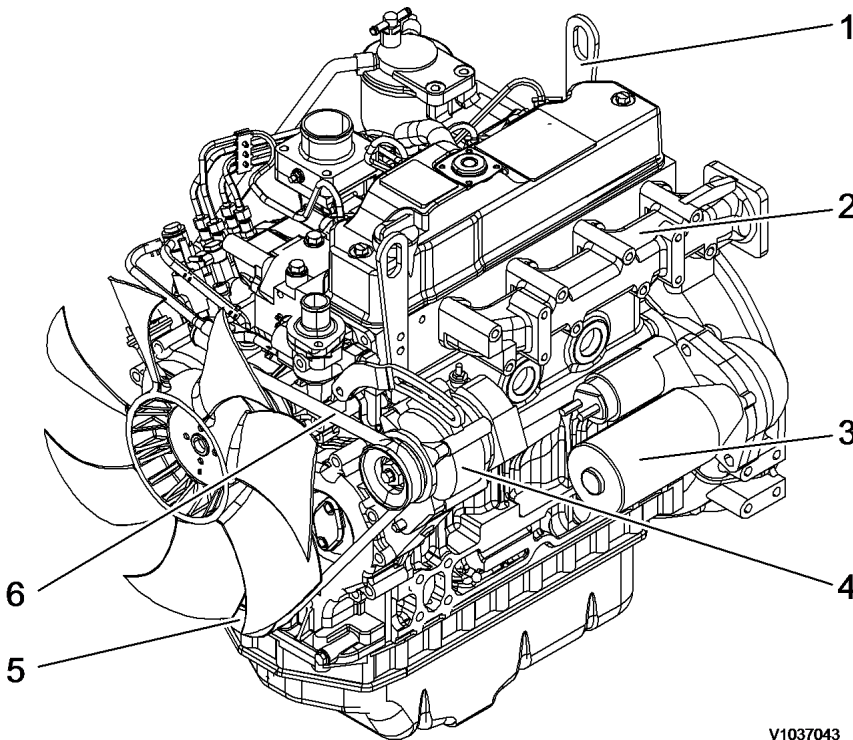

V1037043

Figure 1
Engine, front view

| | | | | | |
|---|------------------|---|---------------|---|---------------------|
| 1 | Lifting eye | 3 | Starter motor | 5 | Crankshaft V-pulley |
| 2 | Exhaust manifold | 4 | Alternator | 6 | V-belt |

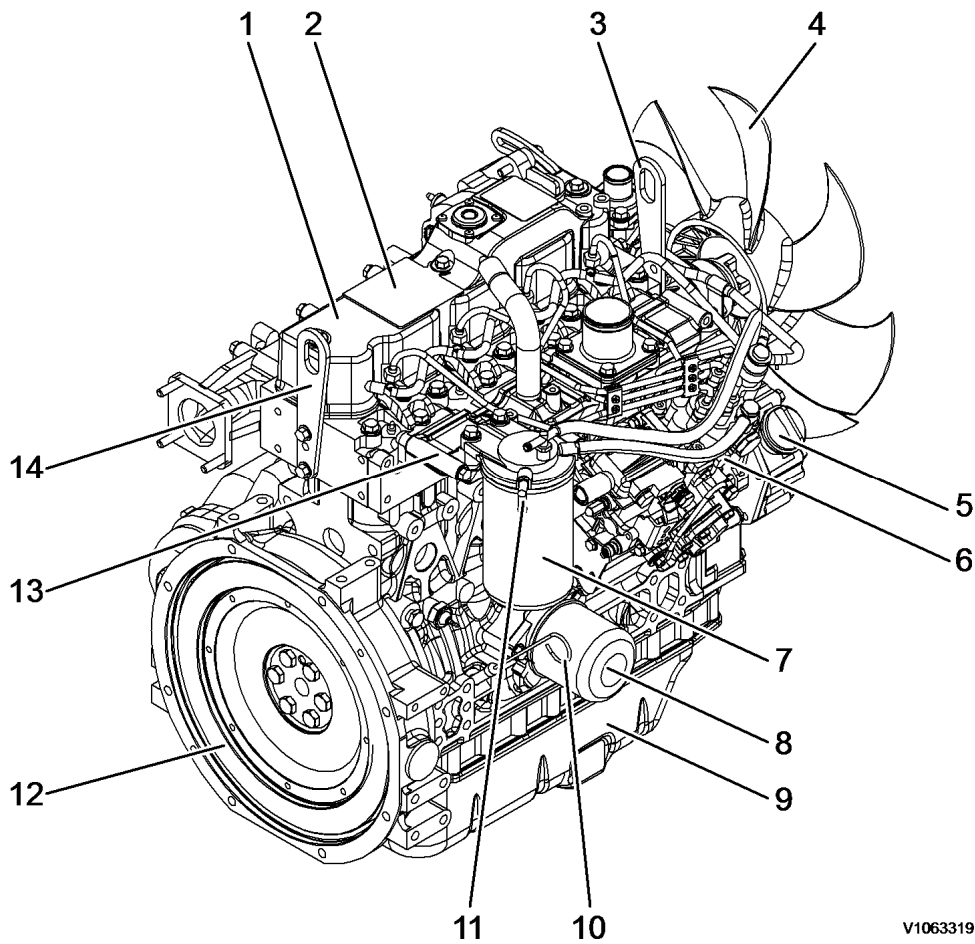

V1063319

Figure 2
Engine, rear view

| | | | | | |
|---|-------------------|----|----------------|----|-----------------|
| 1 | Rocker arm cover | 6 | Injection pump | 11 | Fuel oil inlet |
| 2 | Engine name plate | 7 | Fuel filter | 12 | Flywheel |
| 3 | Lifting eye | 8 | Oil filter | 13 | Intake manifold |
| 4 | Fan | 9 | Oil pan | 14 | Lifting eye |
| 5 | Oil filler port | 10 | Dipstick gauge | | |

| | | | |
|--------------------------------------------|-------------------------------|-------------------------------------------------|----------------------------|
| Document Title: Engine, removing | Function Group: 210 | Information Type: Service Information | Date: 2014/4/6 0 |
| Profile: CEX, ECR48C [GB] | | | |

Engine, removing

Op nbr 210-070

Hoist or crane

Lifting device

WARNING

The work involves handling heavy components - failure to stay alert may result in severe crushing injuries.

1. Place the machine in service position 1. See [091 Service position 1](#).
2. Battery disconnect switch off.

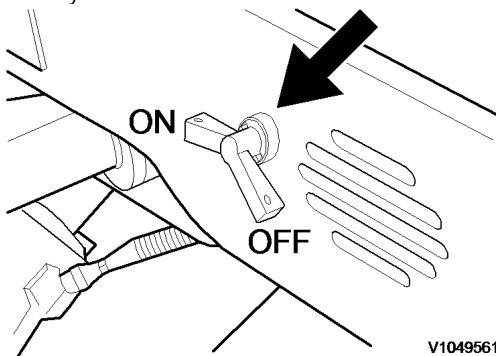

Figure 1
Battery disconnection switch

3. Remove the bonnet.

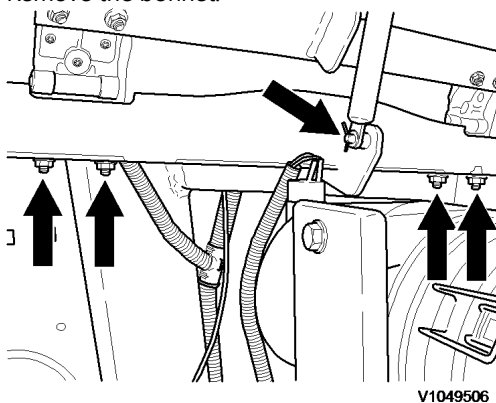

Figure 2
Bonnet, remove

4. Remove rear cover.

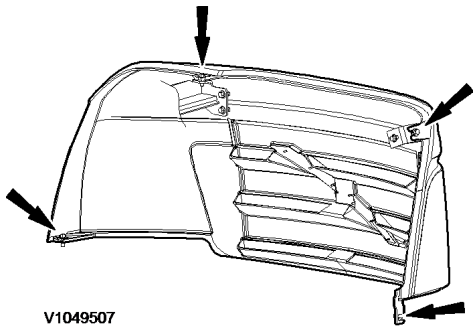

Figure 3
Rear cover, remove

- Remove right-hand side panel.

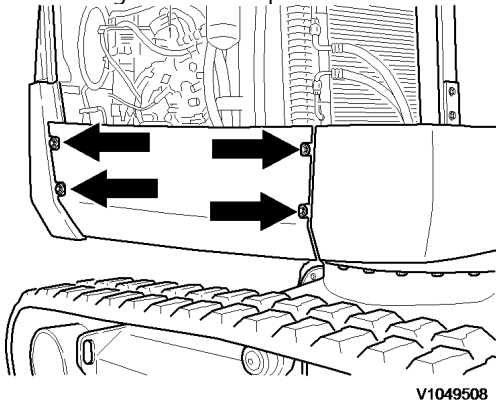

Figure 4
Right-hand side panel, remove

- Remove silencer with tailpipe. See [252 Silencer, removing](#).

! WARNING

Open the radiator cap carefully if the engine is warm. High pressure in the radiator may cause hot coolant to jet out.

! WARNING

Risk of scalding and burns. The coolant may be hot.

- Detach and remove radiator cap (1) on radiator.

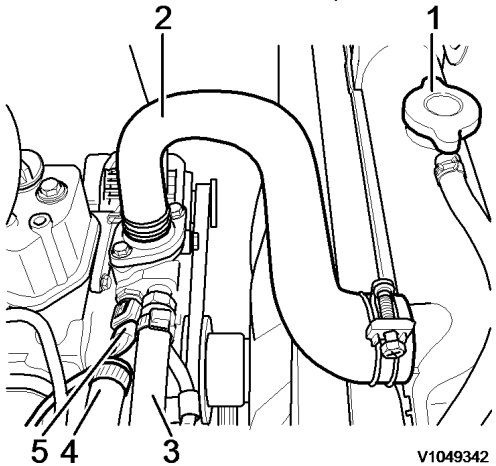

Figure 5
Position of radiator cap

1. Radiator cap
2. Upper radiator hose
3. Feed
4. Return
5. Engine temperature sensor

8. Provide a suitable catchment container for the coolant.

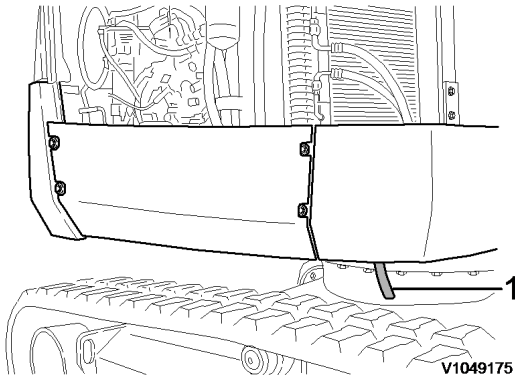

Figure 6
Position, drain valve

1. Drain valve

9. Open the drain valve (1) and drain all coolant into the container.

NOTICE

Cooling system conditioners must be disposed of in accordance with environmental regulations.

NOTICE

Do the work in an environmentally safe manner.

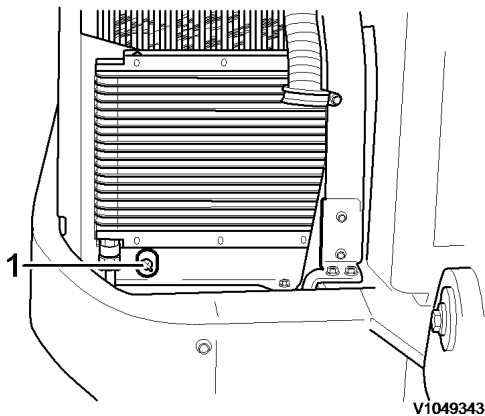

Figure 7
Position of drain plug

1. Drain plug

10. Remove hoses (3, 4) for cab heating on the engine.

NOTICE

When a hose has been disconnected, plug both the hose and the connection immediately. The hoses should be marked for correct connection.

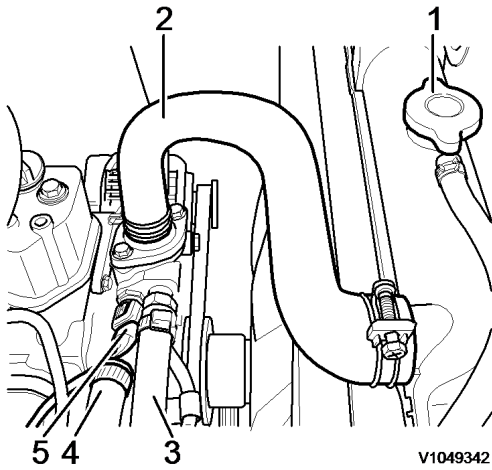

Figure 8
Hoses, remove

1. Radiator cap
2. Upper radiator hose
3. Feed
4. Return
5. Engine temperature sensor

11. Remove the expansion tank from the bracket and drain the fluid into the catch basin.
12. Close the drain valve and screw on the radiator cap.
13. Remove the hose clamp on the upper radiator hose (2) and pull off the hose.
14. Remove the hose clamp on the lower radiator hose (1) and pull off the hose.

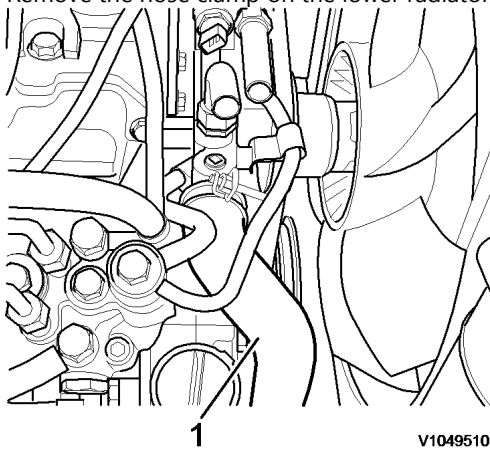

Figure 9
Radiator hose, remove

1. Lower cooler hose

15. Remove the fixing bolts (1) from the fan grille (2) and remove the fan grille.

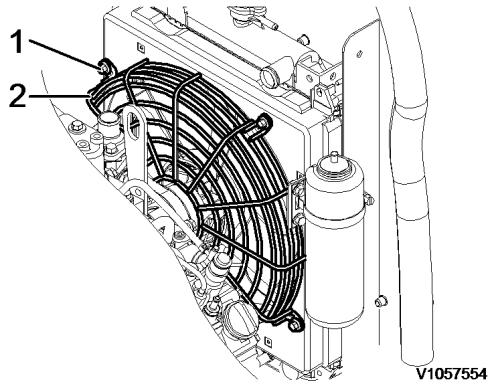

Figure 10
Fan grille, removal

1. Retaining screw
2. Fan grid

16. Turn fuel cock (1) to OFF position.

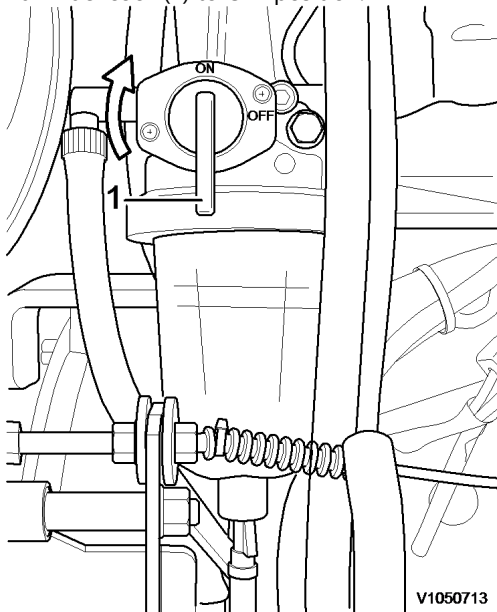

Figure 11
Fuel cock, close.

1. Fuel cock

17. Remove the bolts that hold the fuel prefilter.

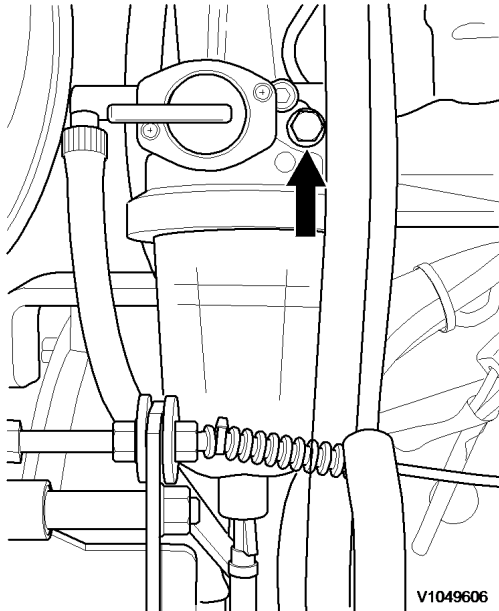

Figure 12
Fuel prefilter fixing bolt

18. Disconnect the electrical connection from the air filter sensor (1) and lay the connecting cable aside.

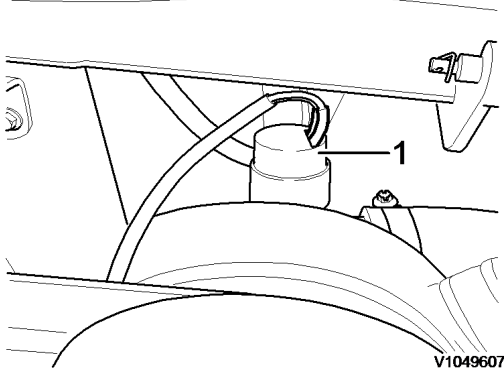

Figure 13
Air filter, remove connections

1. Air cleaner sensor

19. Detach the hose clamp (2) at the intake air hose (3) and pull off the intake air hose (3).

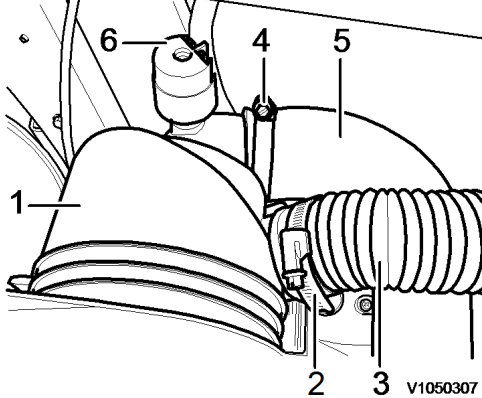

Figure 14
Air filter casing with hose connections

1. Air cleaner casing
2. Hose clamp

- 3. Intake air hose
- 4. Hose clamp
- 5. Air intake hose, engine
- 6. Air cleaner sensor

20. Detach the hose clamp (4) at the engine intake air hose (5) and pull off the engine intake air hose (5).

21. Remove the air filter holder fixing bolts and remove holder together with air filter casing.

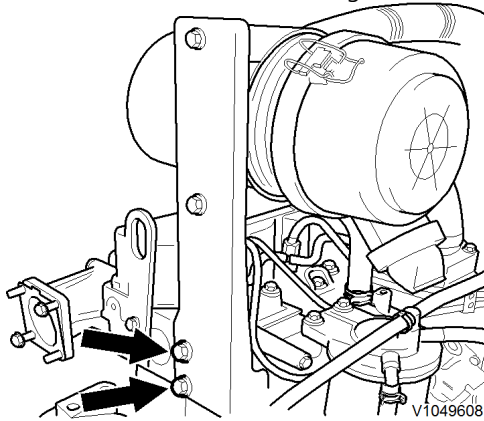

Figure 15
Air filter holder fixing bolts

22. Remove accelerator cable on engine.

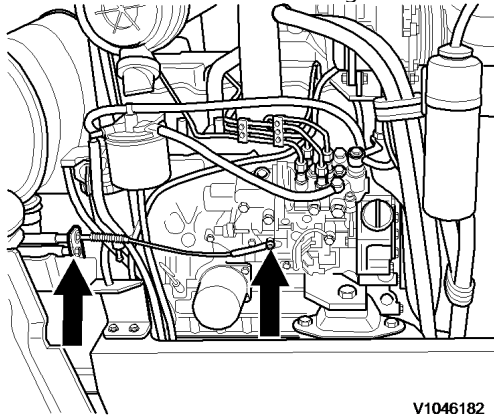
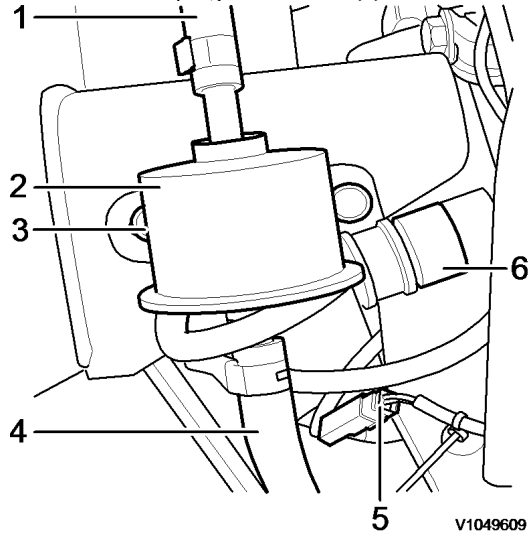

Figure 16
Remove accelerator cable

23. Disconnect the plug connection (5) at the fuel feed pump.



V1049609

Figure 17
Fuel feed pump

1. Output (OUT)
2. Fuel feed pump
3. Retaining screw
4. Input (IN)
5. Plug connection
6. Plug connection, automatic idle control - LS pressure switch

24. Disconnect the plug connection (6) for automatic idle control (option) at LS pressure switch.

25. Disconnect the plug connection (3) for automatic idle control (option).

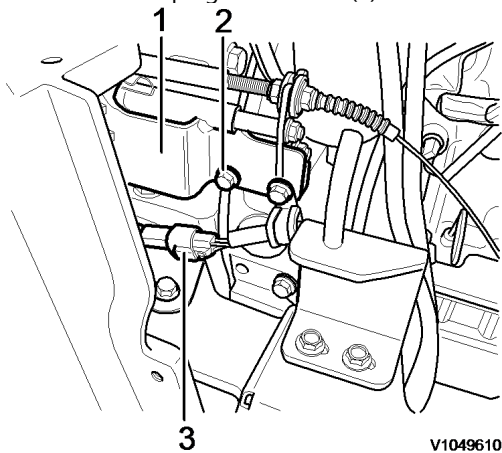

Figure 18
Automatic idle control, remove

1. Holder with magnet
2. Attaching screws
3. Plug connection

26. Remove fixing bolts (2) at the holder, and lay aside holder and magnets (1) for automatic idle control (option).

27. Remove hose lines at the fuel prefilter (1).

NOTICE

When a hose has been disconnected, plug both the hose and the connection immediately. The hoses should be marked for correct connection.

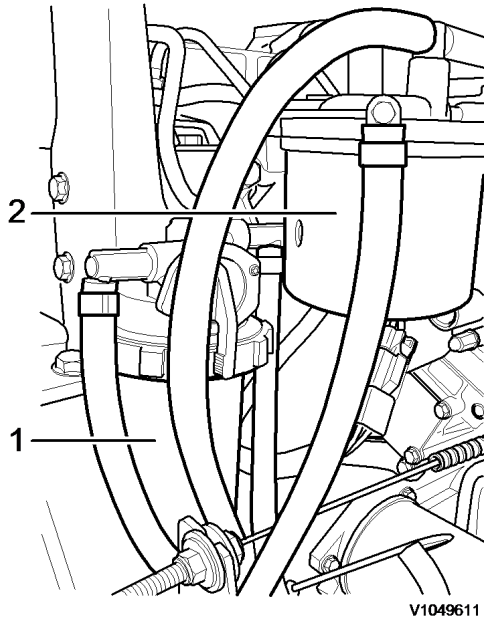

Figure 19
Fuel lines, disconnect

1. Fuel pre-filter
2. Fuel filter

28. Remove hose lines at the fuel filter (2).

NOTICE

When a hose has been disconnected, plug both the hose and the connection immediately. The hoses should be marked for correct connection.

29. Loosen and unscrew the pump mounting bolts.

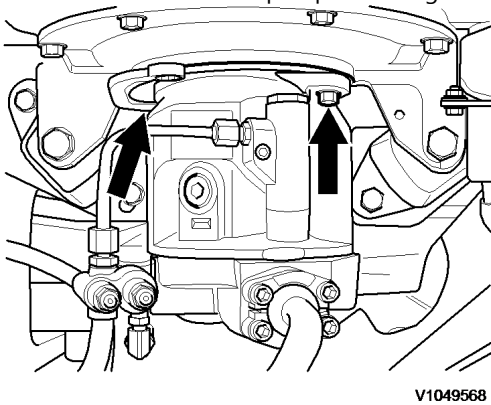
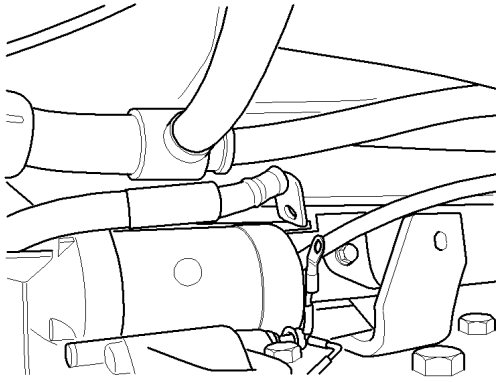

Figure 20
Fixing bolts, remove

30. Pull the pump towards the back and secure against falling.

31. Disconnect the main power supply (terminal 87) from the battery to the starter.



V1049612

Figure 21
Main power supply to starter, disconnect

32. Remove retaining bolts (1) at engine mount.

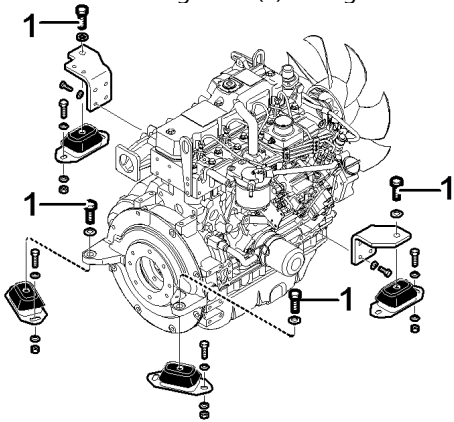

V1049614

Figure 22
Retaining bolts at engine mount, remove

1. Retaining bolts

33. Disconnect plug connections to frame wiring loom and engine shut-off.

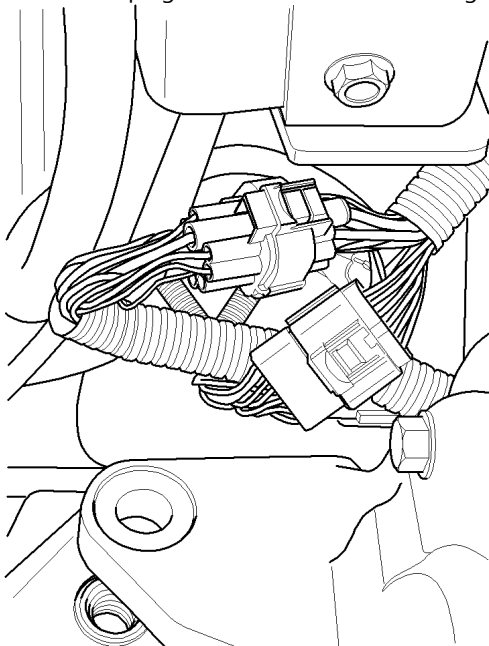

V1049685

Figure 23

Buy Now



Our support email:

ebooklibonline@outlook.com