

| | | | |
|---|-------------------------------|---|----------------------------|
| Document Title: Description D6D | Function Group: 200 | Information Type: Service Information | Date: 2014/5/8 0 |
| Profile: EXC, EW200B [GB] | | | |

Description D6D

The D6D engine is a straight six cylinder, direct-injected four-stroke diesel engine, with electronically controlled fuel injection EMS (Engine Management System).

The engine meets the emission requirements according to EURO2.

The engine number is stamped on the name plate and on the engine block's right side.

Model and serial number must always be indicated when ordering spare parts.

| | | | |
|---|-------------------------------|---|----------------------------|
| Document Title: Engine, removal | Function Group: 210 | Information Type: Service Information | Date: 2014/5/8 0 |
| Profile: EXC, EW200B [GB] | | | |

Engine, removal

Op nbr 210-01

Lifting links, min. 1000 kg

Hose with valve



Risk of burns - stop the diesel engine and allow it to cool down before starting any work.

NOTE!

Clamps that secure hoses and wiring should be removed and replaced when installing.

1. Turn off the electric power with the battery disconnecter.

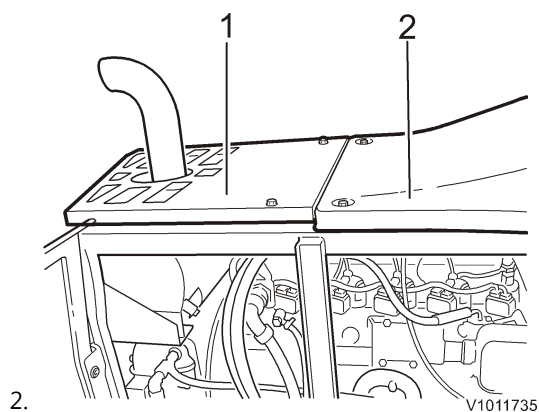

Figure 1
Superstructure

1. Cover
2. Cover

Remove the covers over the diesel engine.

3. Remove the protective plates under the engine.
4. Connect a hose with valve (tool equipment) and drain the coolant from the radiator into a clean container. Filled radiator contains approx. 22 litres.
5. Connect a hose with valve (tool equipment) and drain the hydraulic oil from the hydraulic oil tank into a clean container. Filled tank contains approx. 190 litres.
6. Disconnect the connections to the sight glass for the hydraulic oil tank. Plug and mark.
7. Remove the hood opener.

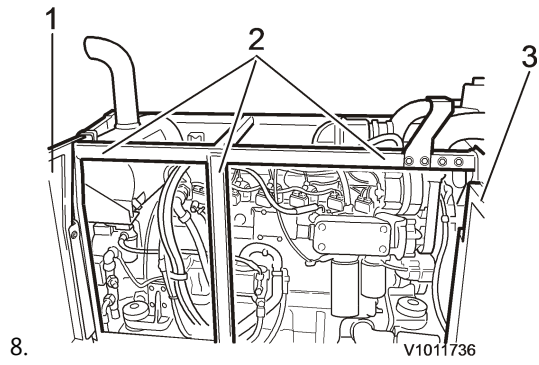

Figure 2
Framework

1. Cover
2. Framework
3. Cover

Disconnect the outer framework and lift away the frame with the covers.

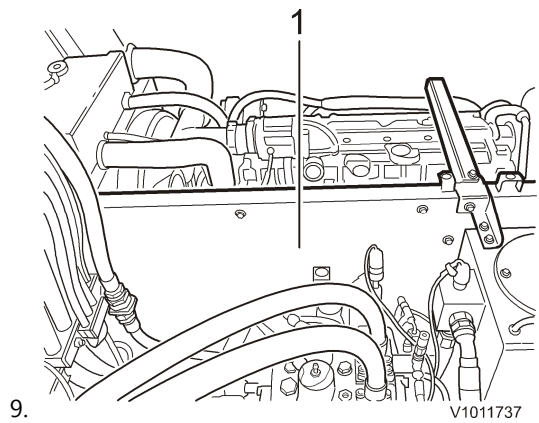

Figure 3
Engine/hydraulic compartment

1. Intermediate wall

Remove the intermediate wall.

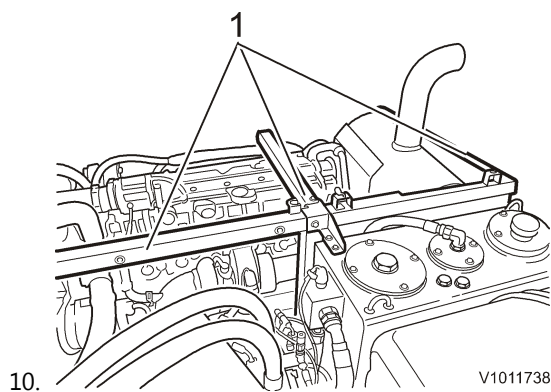

Figure 4
Engine/hydraulic compartment

1. Framework

Remove the remaining framework.

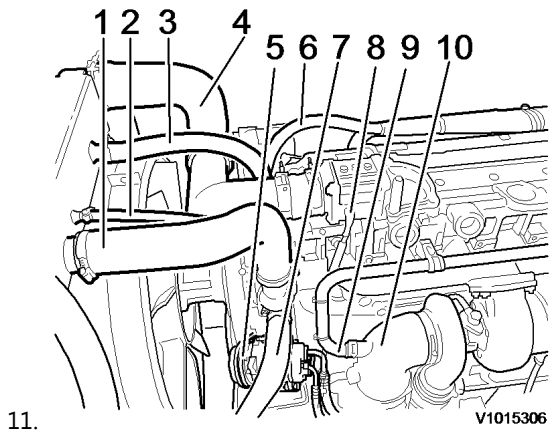

Figure 5
Radiator/engine

- | | |
|---------------------|-----------------------------|
| 1. Cooling hose | .6 Cooling hose |
| 2. Cooling hose | 7. Cooling hose |
| 3. Cooling hose | 8. Cabling |
| 4. Intercooler hose | 9. Induction hose to turbo |
| 5. AC compressor | 10. Induction hose to turbo |

Disconnect the engine from the cooling hoses. Remove the upper intercooler hose and disconnect the lower from the engine.

Disconnect the engine from the inductions hoses for the turbo.

Disconnect (if installed) the AC compressor from the engine, and remove the Vee-belts.

NOTE!

Do NOT loosen the hoses from the compressor.

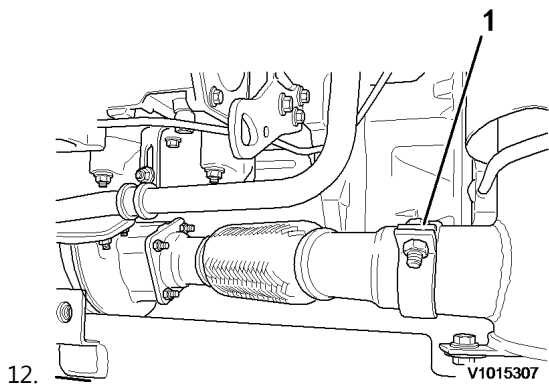

Figure 6
Exhaust pipe/muffler

1. Exhaust clamp

Loosen the exhaust clamp.

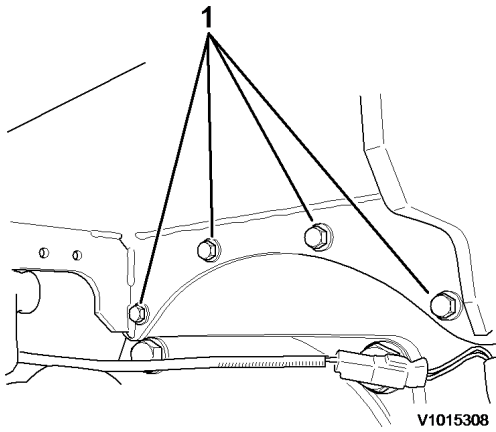

Figure 7
Underside muffler bracket

1. Attaching bolts

Remove the attaching bolts for the muffler bracket and remove the muffler and bracket.

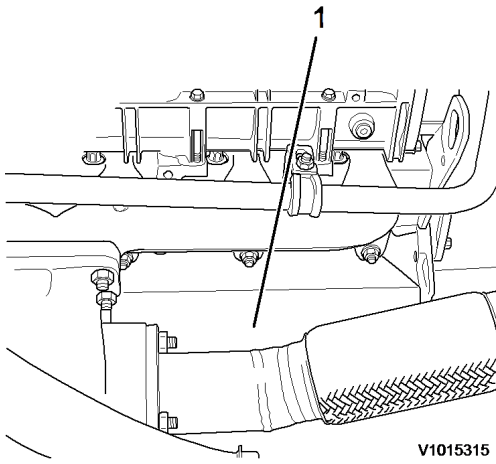

Figure 8
Cover plate over starter motor

1. Cover plate

Remove the cover plate over the starter motor.

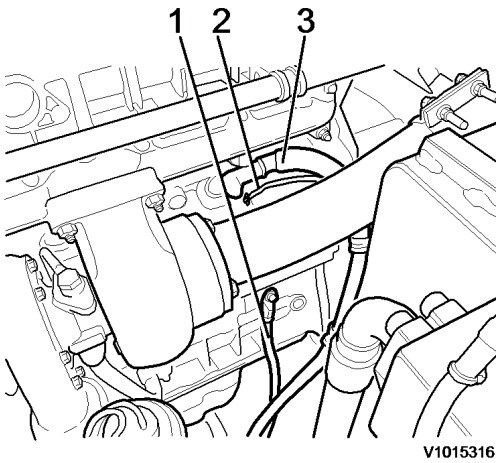

Figure 9
Engine/Starter motor

1. Ground connection
2. Cabling
3. Cabling

Disconnect the cabling for the starter motor and ground connection.

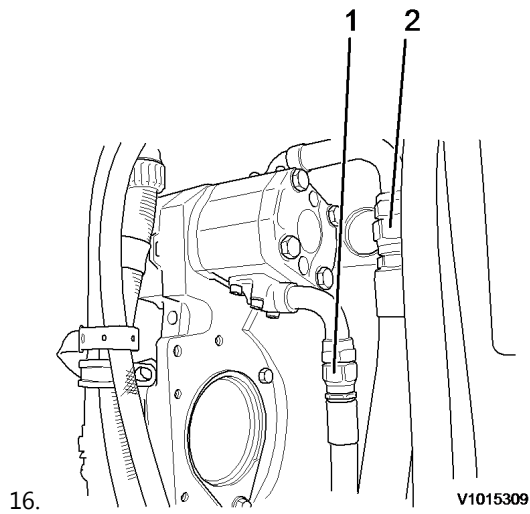

Figure 10
Fan pump

1. Hydraulic hose
2. Hydraulic hose

Disconnect the fan pump from the hydraulic oil hoses. Plug and mark up. (Only installed if machine is equipped with hydraulic cooling fan.)

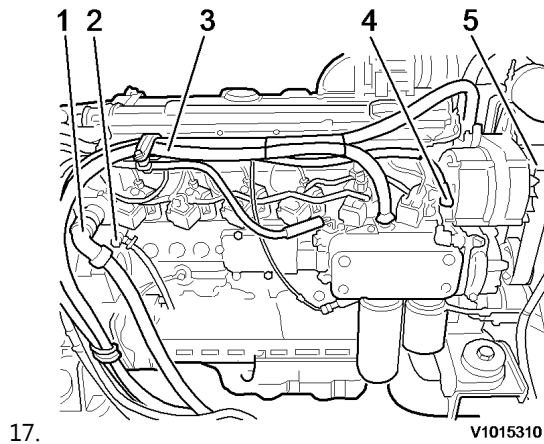

Figure 11
Engine, side view

1. Cabling
2. Fuel line
3. Cooling hose
4. Cabling
5. Fuel line

Disconnect the engine from the cabling, fuel lines and cooling hose. Plug and mark up.

18. Remove the servo pump according to [914 Servo pump, removal](#).
19. Remove the working pump according to [913 Pump, removal](#).

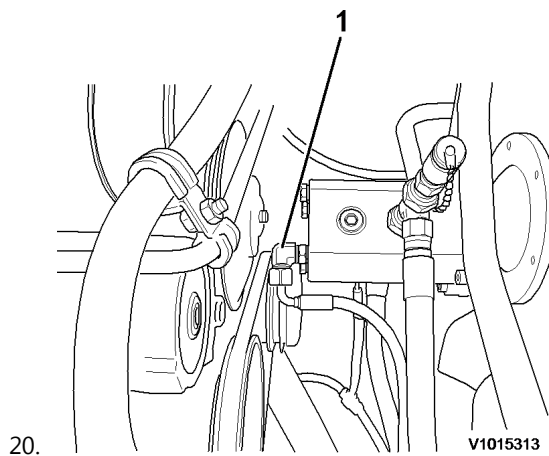

Figure 12
Hydraulic cooling fan

1. Elbow nipple

If hydraulically driven cooling fan (option): Remove the elbow nipple on the cooling fan and plug.

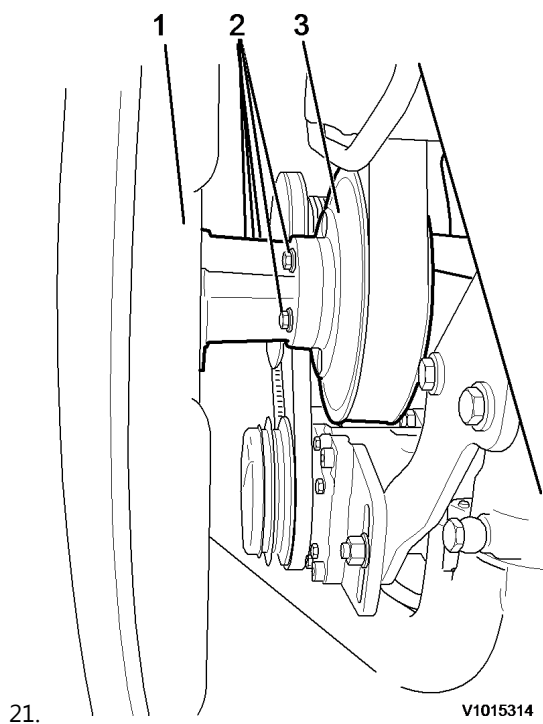
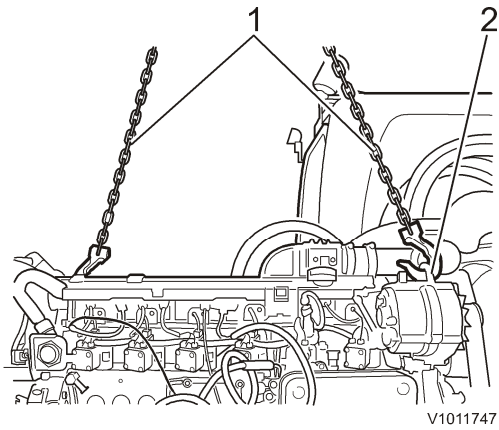

Figure 13
Belt-driven cooling fan

1. Cooling fan
2. Attaching bolts
3. Belt pulley

If belt-driven cooling fan: Remove the attaching bolts for the belt pulley.
Remove the cooling fan.



22.

Figure 14
Lifting links on engine

1. Lifting links
2. Lifting eyes

Connect the lifting links in the engine's lifting eyes and in a lifting device.
Tighten up the lifting links.

23. Remove the bolted joints for the engine mounts.
24. Lift out the engine carefully.
25. Place the engine on stable supports.

| | | | |
|--|-------------------------------|---|----------------------------|
| Document Title: Engine, installation | Function Group: 210 | Information Type: Service Information | Date: 2014/5/8 0 |
| Profile: EXC, EW200B [GB] | | | |

Engine, installation

Op nbr 210-02

14360000 Vacuum pump

Lifting links, min. 1500 kg

1. Lift in the engine carefully.
2. Fit the bolted joints for the engine mounts.
Tightening torque: $687 \pm 68\text{Nm}$.

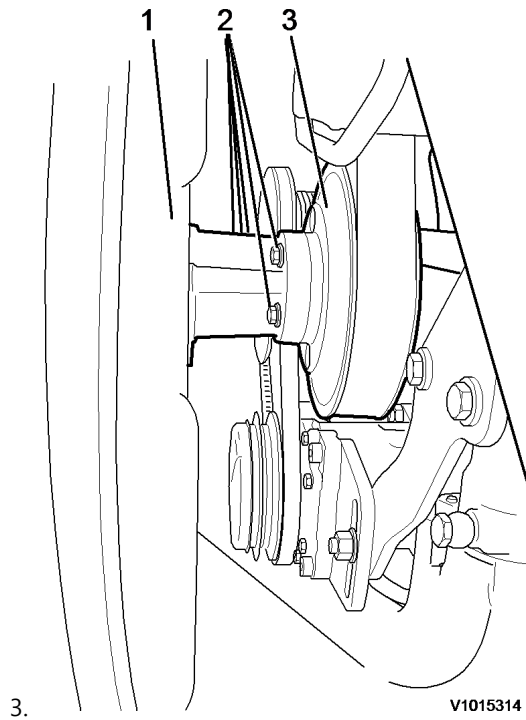

Figure 1
Belt-driven cooling fan

1. Cooling fan
2. Attaching bolts
3. Belt pulley

If belt-driven cooling fan: Fit the cooling fan and fit the attaching bolts for the belt pulley.

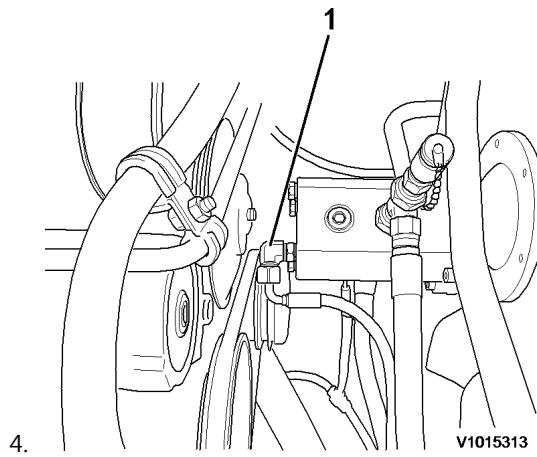

Figure 2
Hydraulically driven cooling fan

1. Elbow nipple

If hydraulically driven cooling fan (option): Fit the elbow nipple on the cooling fan.

5. Fit the working pump according to [913 Pump installation](#).
6. Fit the servo pump according to [914 Servo pump installing](#).

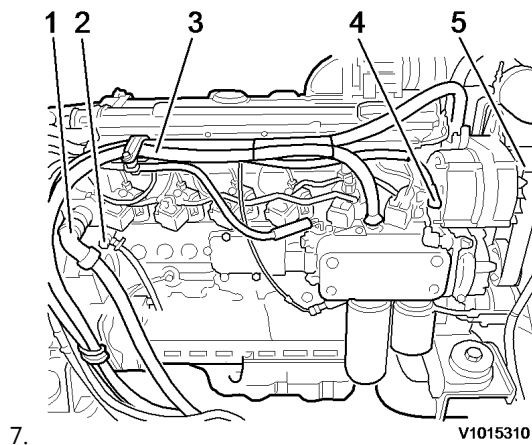

Figure 3
Engine, side view

1. Cabling
2. Fuel line
3. Cooling hose
4. Cabling
5. Fuel line

Fit cabling, fuel lines and cooling hose.

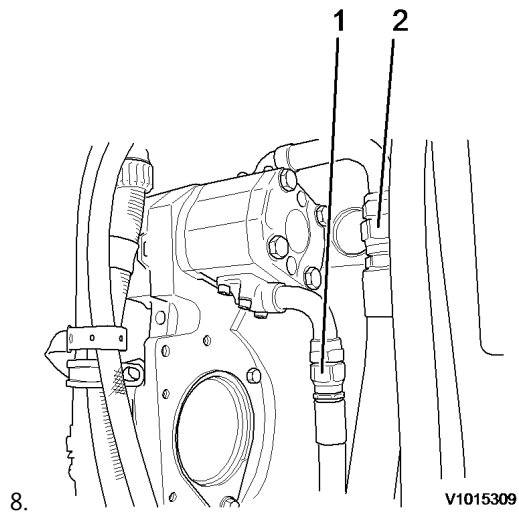

Figure 4
Fan pump

1. Hydraulic hose
2. Hydraulic hose

Fit the fan pump's hydraulic oil hoses. (Only installed if machine is equipped with hydraulically driven cooling fan.)

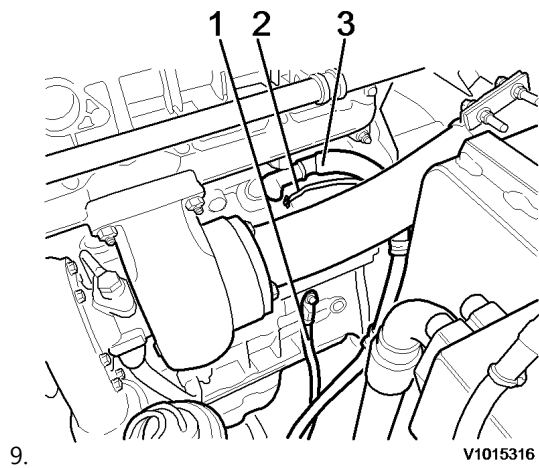

Figure 5
Engine/starter motor

1. Ground connection
2. Cabling
3. Cabling

Fit the cabling for the starter motor and the ground connection.

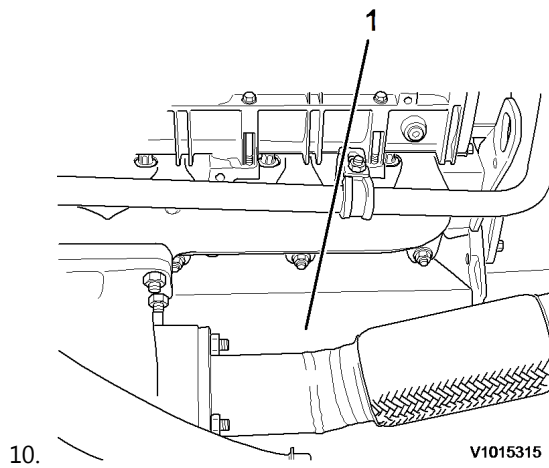

Figure 6
Cover plate over starter motor

1. Cover plate

Fit the cover plate over the starter motor.

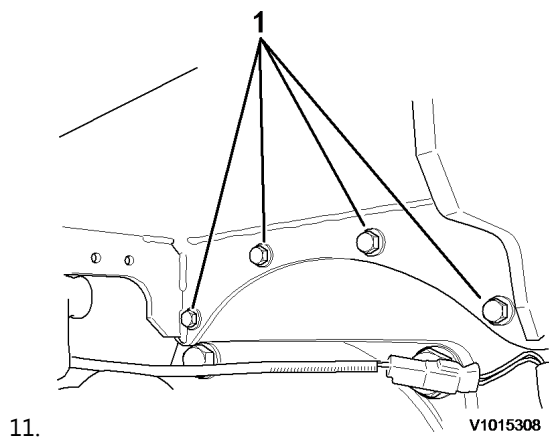

Figure 7
Underside muffler bracket

1. Underside muffler bracket

Fit the muffler bracket with the muffler.
Fit the attaching bolts for the bracket.

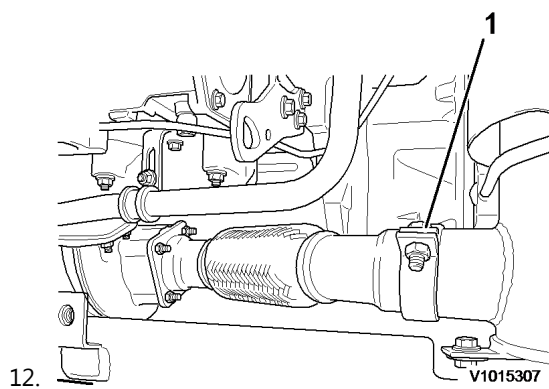
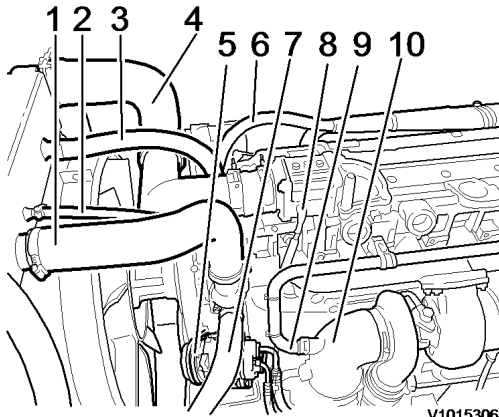

Figure 8
Exhaust pipe/muffler

1. Exhaust clamp

Fit the exhaust clamp.



13.

V1015306

Figure 9
Radiator/engine

| | |
|---------------------|-----------------------------|
| 1. Cooling hose | .6 Cooling hose |
| 2. Cooling hose | 7. Cooling hose |
| 3. Cooling hose | 8. Cabling |
| 4. Intercooler hose | 9. Induction hose to turbo |
| 5. AC compressor | 10. Induction hose to turbo |

Fit the Vee-belts and the AC compressor.

Fit the upper and lower intercooler hose.

Fit the cooling hoses.

Fit the induction hoses for the turbo.

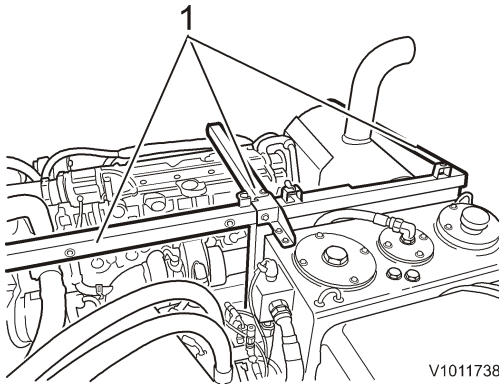

14.

V1011738

Figure 10
Engine/hydraulic compartment

1. Framework

Fit the inner framework.

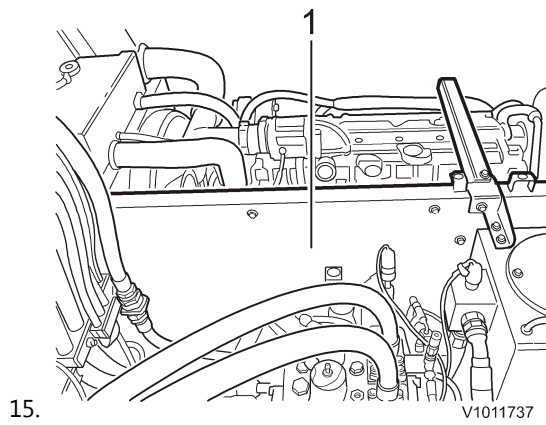

Figure 11
Engine/hydraulic compartment

1. Intermediate wall

Fit the intermediate wall.

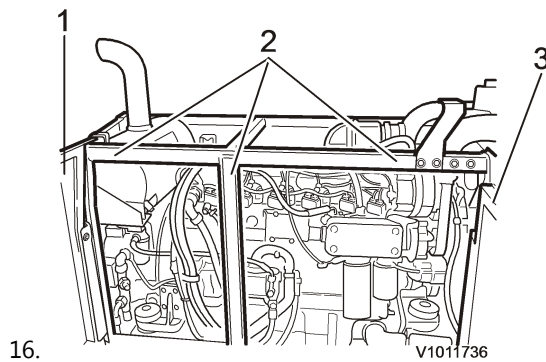

Figure 12
Framework

1. Cover
2. Framework
3. Cover

Fit the covers and the outer framework.

17. Fit the hood opener.
18. Fit the connections for the sight glass for the hydraulic oil level.
19. Fill the hydraulic oil tank with hydraulic oil.
The tank's capacity is approx. 190 litres.

Buy Now



Our support email:

ebooklibonline@outlook.com