

Document Title: <b>Engine, identification</b>	Function Group: <b>200</b>	Information Type: <b>Service Information</b>	Date: <b>2014/5/4 0</b>
Profile: <b>EXC, EW210D [GB]</b>			

## Engine, identification

### Identification plate

The engine model, serial number and performance data are stamped on an identification plate which is attached on the cylinder head cover. The engine model designation and serial number must be indicated when ordering spare parts.

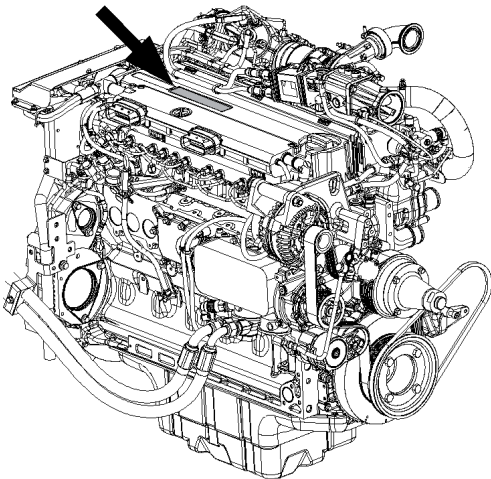

V1105285

**Figure 1**  
**Engine identification, D6H**

Document Title: <b>Component locations</b>	Function Group: <b>200</b>	Information Type: <b>Service Information</b>	Date: <b>2014/5/4 0</b>
Profile: <b>EXC, EW210D [GB]</b>			

## Component locations

The following figures show the position of a number of components on engine D6H.

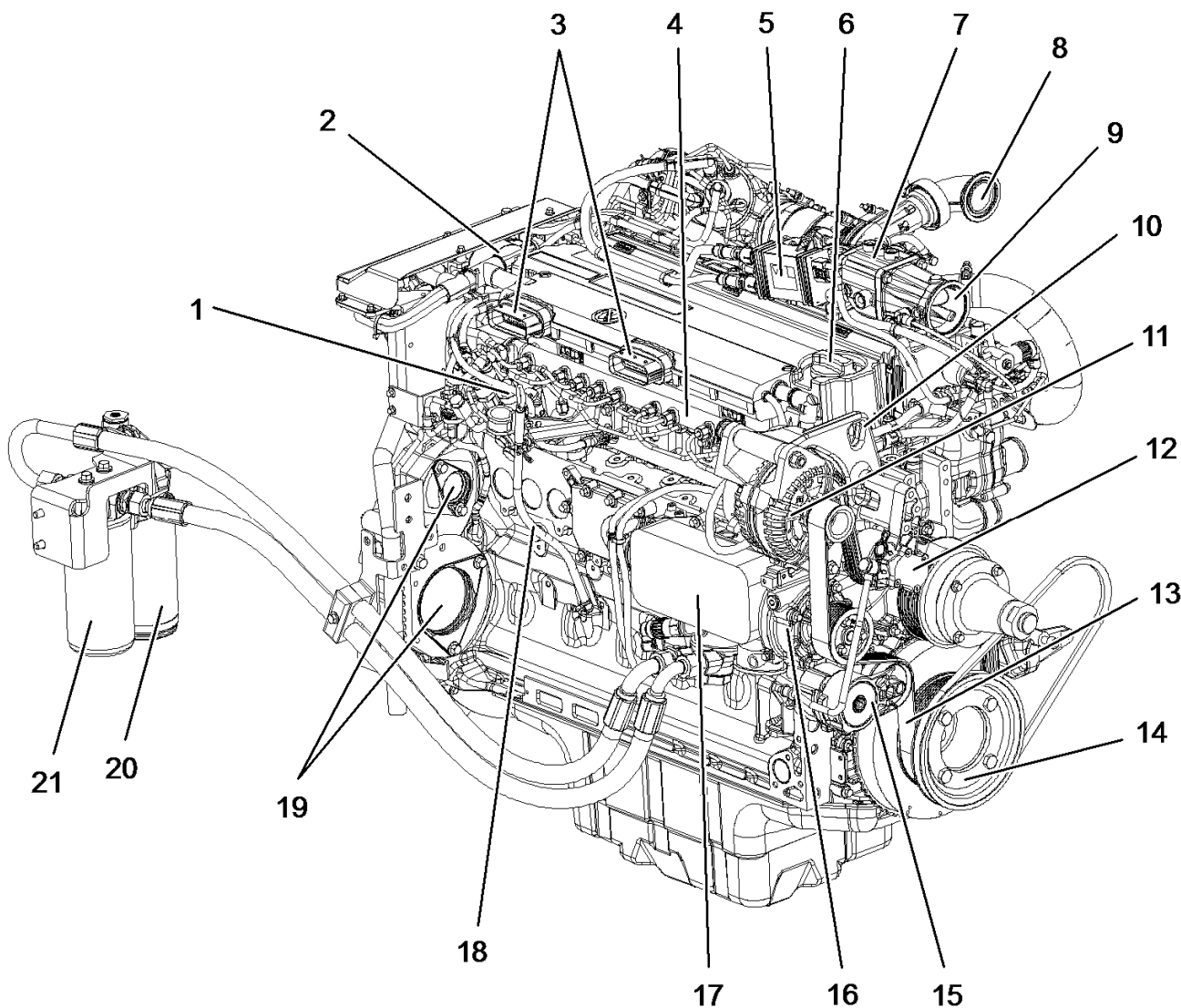

V1102441

**Figure 1**  
**Component locations, front view**

- |   |                                  |    |                                |
|---|----------------------------------|----|--------------------------------|
| 1 | High pressure fuel pumps         | 12 | Fuel feed pump                 |
| 2 | Crankcase bleeding valve         | 13 | V-rib belt                     |
| 3 | Connectors to E-ECU              | 14 | V-rib belt drive on crankshaft |
| 4 | Common fuel rail                 | 15 | Automatic belt tensioner       |
| 5 | Spark plug control unit (CU2503) | 16 | Coolant pump                   |
| 6 | Engine oil filler cap            | 17 | Engine oil cooler              |
| 7 | Pre heater (HE2501)              | 18 | Oil dipstick                   |

8	Air outlet (to charge air cooler)	19	Power take off
9	Air inlet (from charge air cooler)	20	Fuel filter
10	Transport eye	21	Engine oil filter
11	Alternator (AL3201)		

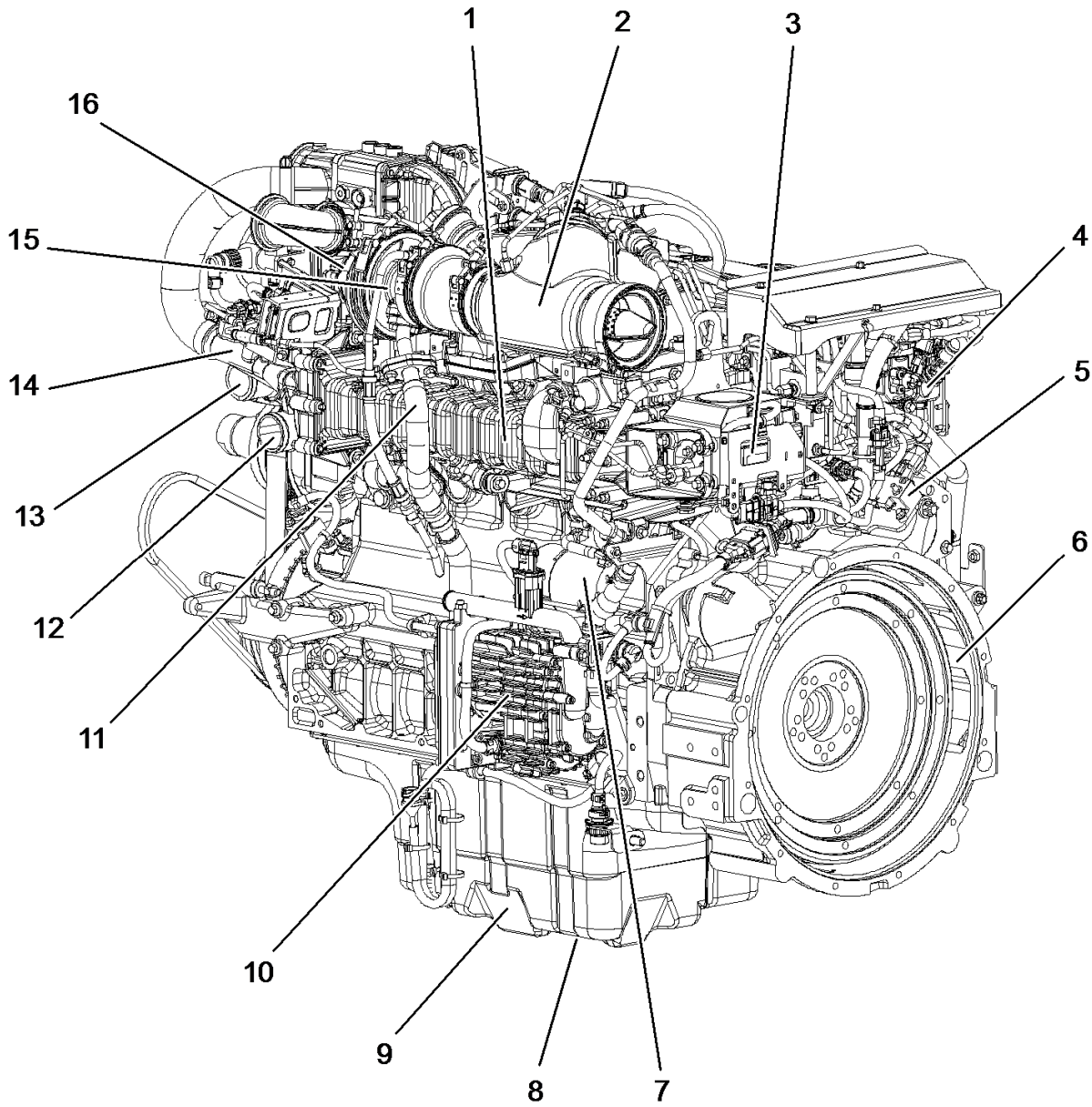

V1102442

**Figure 2**  
**Component locations, rear view**

1	EGR cooler	9	Oil sump
2	Burner	10	Air pump
3	EGR actuator	11	Oil return line from turbocharger
4	EATS fuel metering units	12	Coolant inlet
5	Glow plug control unit (CU2501)	13	Coolant outlet
6	Flywheel housing	14	Venturi tube
7	Starter motor (MO3301)	15	Turbo charger
8	Drain plug	16	Air inlet (from air filter)

Document Title: <b>Component location, sensors</b>	Function Group: <b>200</b>	Information Type: <b>Service Information</b>	Date: <b>2014/5/4 0</b>
Profile: <b>EXC, EW210D [GB]</b>			

## **Component location, sensors**

The following figures show the position of sensors and electric components on the engine D6H.

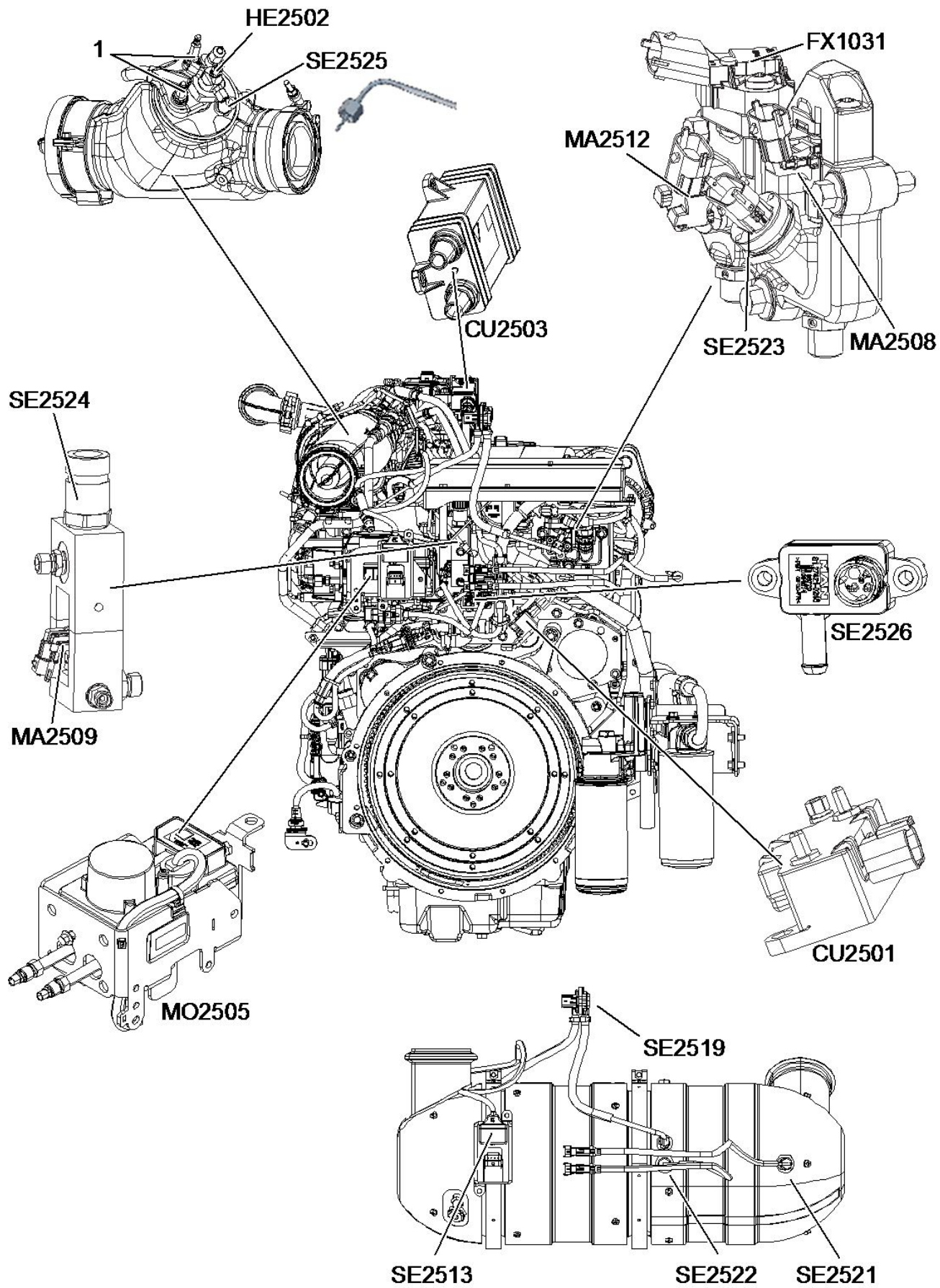

V1104451

Figure 1  
View pump side

**Components view pumps side**

<b>Name</b>	<b>Description</b>	<b>Name</b>	<b>Description</b>
1	Spark plugs	FX1031	Fuel temperature and pressure sensor before MV 1 +2
HE2502	Glow plug	MA2508	Fuel metering valve MV1
SE2513	NOx sensor	MA2509	Fuel metering valve MV2
SE2519	DPF differential pressure sensor	MA2512	Shut-off valve
SE2521	Exhaust gas temperature sensor before DOC	CU2501	Glow plug control unit
SE2522	Exhaust gas temperature sensor after DOC	CU2503	Spark plug control unit
SE2523	Fuel pressure sensor after MV1	MO2505	EGR actuator
SE2524	Fuel pressure sensor after MV2		
SE2525	Burner exhaust temperature sensor		
SE2526	Exhaust gas pressure sensor		



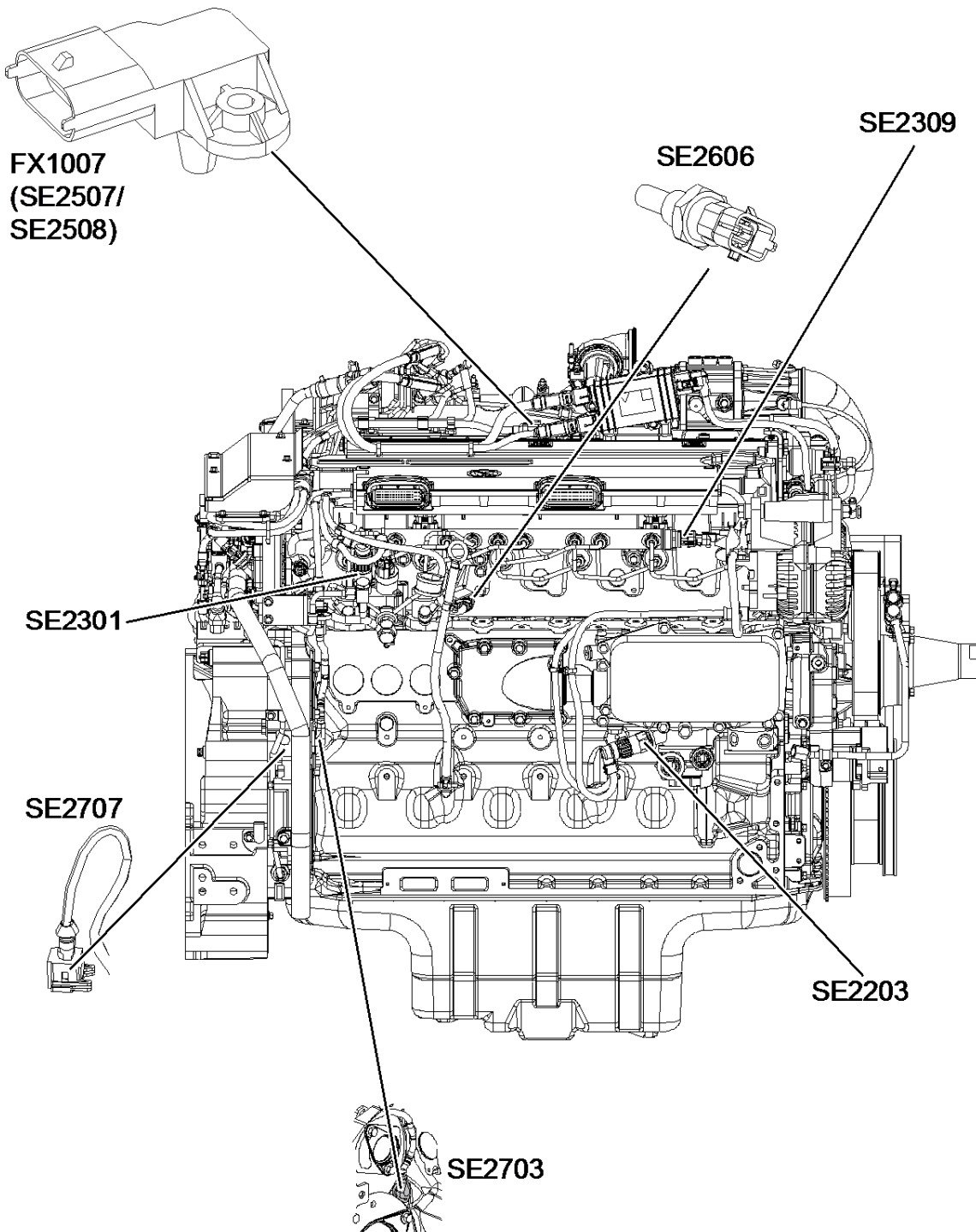

V1104452

**Figure 2**  
View front side

**Components front side**

Name	Description	Name	Description
FX1007 SE2507/SE2508	Boost air pressure and temperature sensor	SE2606	Engine coolant temperature sensor
SE2203	Engine oil pressure sensor	SE2703	Engine speed sensor, camshaft
SE2301	Fuel feed pressure sensor	SE2707	Engine speed sensor, crankshaft second
SE2309	Common rail fuel pressure		

sensor

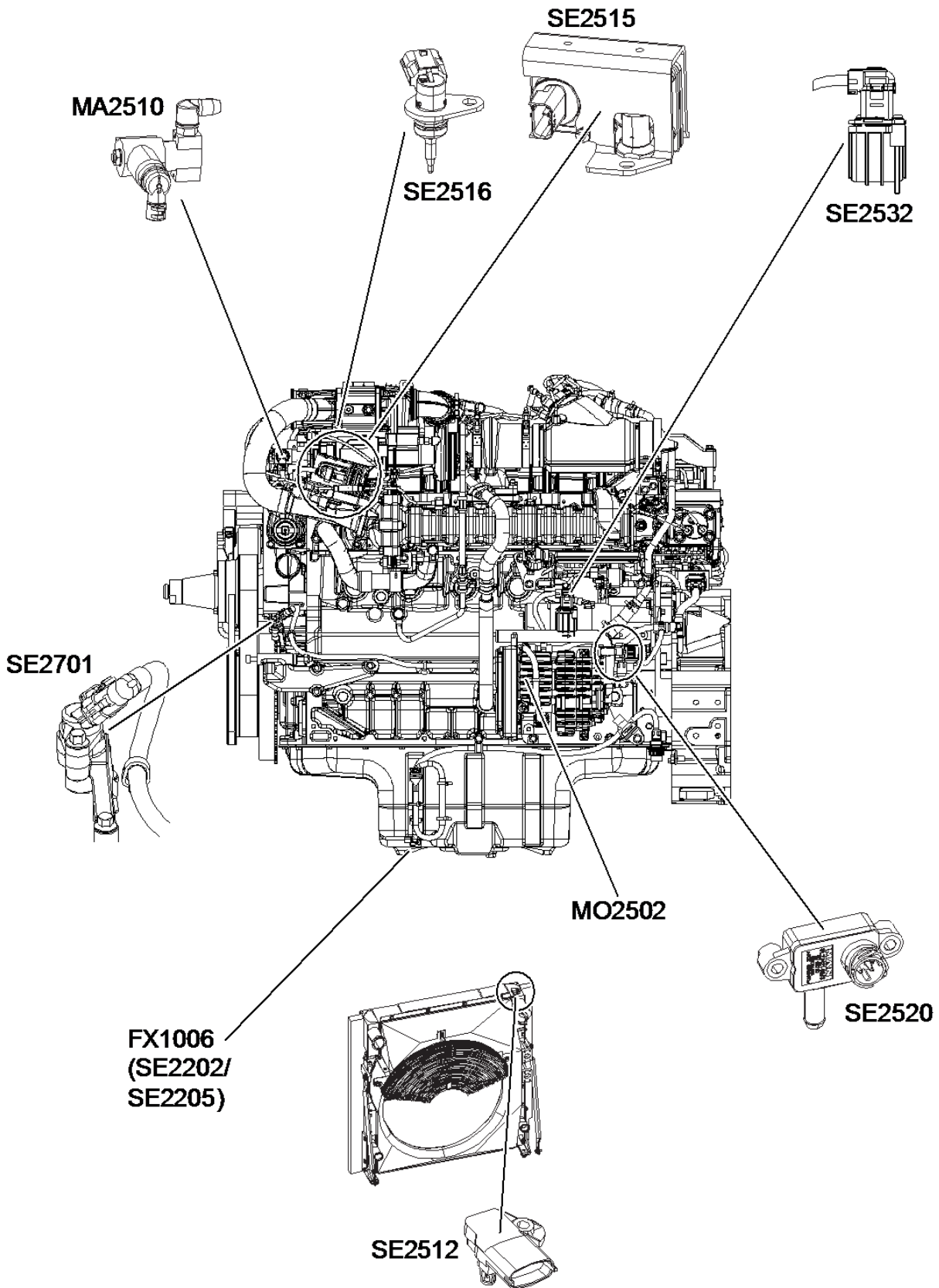

V1104453

Figure 3  
View rear side



**Components front side**

<b>Name</b>	<b>Description</b>	<b>Name</b>	<b>Description</b>
FX1006 SE2202/SE2205	Engine oil temperature and level sensor	SE2532	Air pump mass flow sensor
SE2512	Charge air temperature cooler	SE2701	Engine speed, crankshaft first
SE2515	EGR differential pressure sensor	MA2510	Purge air valve (PAV)
SE2516	EGR temperature sensor	MO2502	Air pump motor
SE2520	Air pump pressure sensor		

Document Title: <b>Valves, adjusting</b>	Function Group: <b>214</b>	Information Type: <b>Service Information</b>	Date: <b>2014/5/4 0</b>
Profile: <b>EXC, EW210D [GB]</b>			

## Valves, adjusting

Op nbr 214-012

[9998681 Rotation tool](#)

[885812 Timing tool](#)

### **WARNING**

**Risk of burns - stop the diesel engine and allow it to cool down before starting any work.**

1. Place the machine in service position B, see [091 Service positions](#).
2. Turn **OFF** the battery disconnect switch.

### Valve cover, removing

3. Remove the valve cover, see [214 Valve cover, removing](#)

**NOTE!**

For valve adjusting it is not necessary to remove the valve cover gasket!

4. Remove the cover (1) in order to apply the special tool.

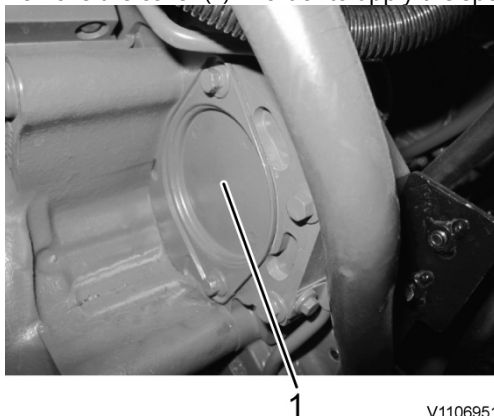

**Figure 1**  
**Cover**

### Setting the valve overlap for cylinder 1

5. Install the rotation tool (1).  
Special tool: 9998681 Rotation tool

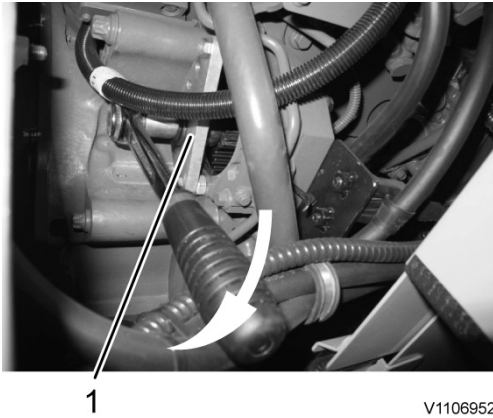

V1106952

**Figure 2**  
**Rotating tool**

6. Turn the crankshaft using the rotation tool (1) until the valve overlap of cylinder 1 is reached.
7. Set the valve overlap for cylinder 1.
  - The valve overlap for a cylinder is reached when the outlet valve is about to close and the inlet valve is about to open. It should not be possible to rotate any push rods by hand for the cylinder in this position.

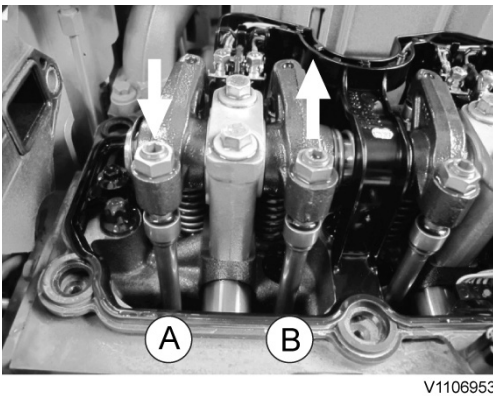

V1106953

**Figure 3**  
**Overlapping**

- A — Outlet valve
- B — Inlet valve

8. The black marked valves in the setting schematic can be adjusted. Set the clearance for inlet and outlet valves by following the steps:

- **Setting the inlet valve clearance**
- **Setting the outlet valve clearance**

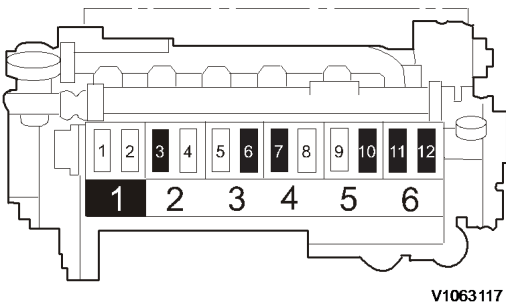

V1063117

**Figure 4**  
**Setting schematic overlap cylinder 1 (located on the flywheel side)**

6, 10, 12 are inlet valves  
3, 7, 11 are outlet valves

## Setting the inlet valve clearance

9. Set inlet valve clearance according to the setting schematic for overlapped cylinder.

- Loosen lock nut (1) counterclockwise.  
Turn setting screw (2) clockwise by hand until it stops.

### NOTE!

The rocker arm (4) must touch the thrust washer (3) of the spring cap (5).

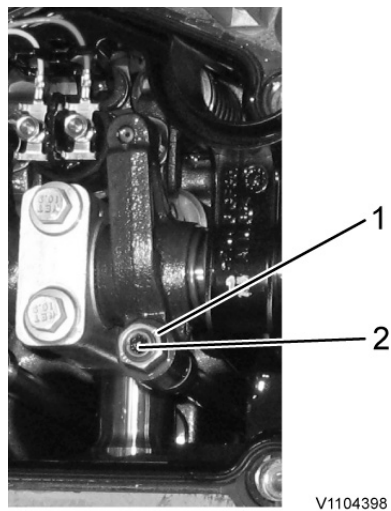
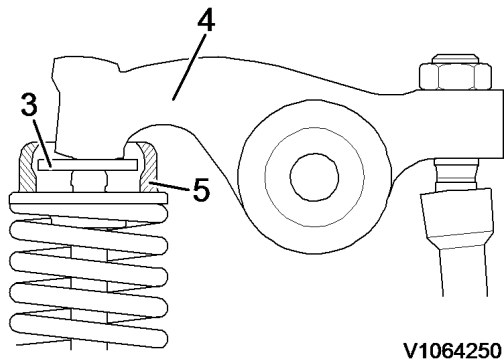

**Figure 5**  
**Rocker arm inlet valve**

- Set special tool (885812 Timing tool) on the setting screw with a suitable socket.  
Fix magnet of the special tool to the cylinder head.  
Set the angle gauge clockwise to "0".



**Figure 6**  
**Set to zero**

- Turn the setting screw **75° counterclockwise**.

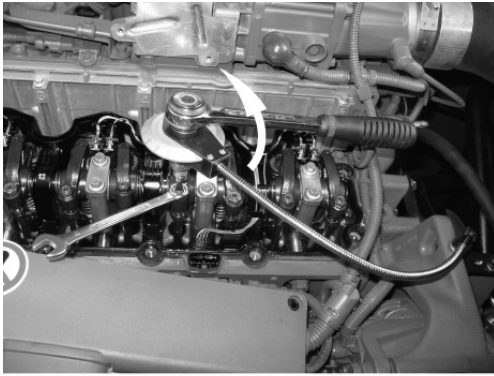

V1104400

**Figure 7**

**Set clearance**

- Hold the setting screw to prevent it turning and tighten the lock nut clockwise, tightening torque: **20 Nm (14.8 lbf ft)**.

**Setting the outlet valve clearance**

10. Set the outlet valve clearance according to the setting schematic for overlapped cylinder.

- Loosen lock nut (1) counterclockwise.  
Turn setting screw (2) clockwise by hand until it stops.

**NOTE!**

The rocker arm must touch the thrust washer of the spring cap (arrow).

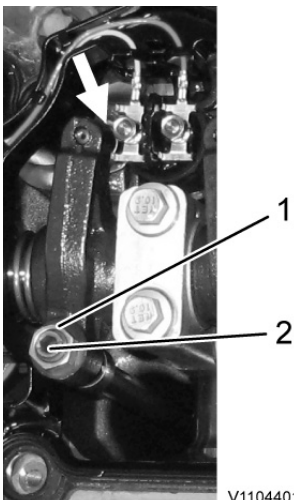

V1104401

**Figure 8**

**Rocker arm outlet valve**

- Set special tool (885812 Timing tool) on the setting screw with a suitable socket. Fix magnet of special tool to the cylinder head. Set the angel gauge clockwise to **"0"**.



V1104399

**Figure 9**  
**Set zero**

- Turn the setting screw **120° counterclockwise**.

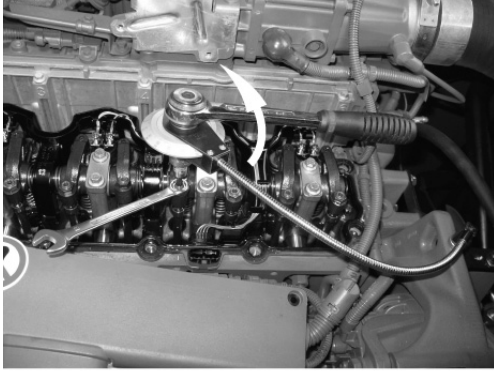

V1104400

**Figure 10**  
**Set clearance**

- Hold the setting screw to prevent it turning and tighten the lock nut clockwise, tightening torque **20 Nm (14.8 lbf ft)**.

### Set the valve overlap for cylinder 6

11. Turn the crankshaft using the rotation tool (1) clockwise one turn (360°).

**NOTE!**

Make a check mark on the belt pulley for better control.

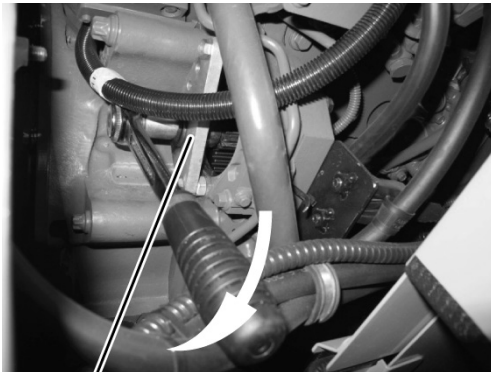

1

V1106952

**Figure 11**  
**Rotating tool**

12. Set the valve overlap for cylinder 6.
  - The valve overlap for a cylinder is reached when the outlet valve is about to close and the inlet valve is about to open. It should not be possible to rotate any push rods by hand for the cylinder in this position.



**Buy Now**



Our support email:

[ebooklibonline@outlook.com](mailto:ebooklibonline@outlook.com)