

Document Title: <b>Engine, description</b>	Function Group: <b>200</b>	Information Type: <b>Service Information</b>	Date: <b>2014/3/8 0</b>
Profile: <b>CWL, L25B [GB]</b>			

## Engine, description

Machines with **SN 1750001 – / – 1753000** are fitted with the VOLVO D3D engine.

The engine is a four-cylinder, four-stroke, in-line diesel engine with direct injection and oil/air cooling.

Machines **from SN 1753001 –** are fitted with the VOLVO D3.6D engine.

he engine is a four-cylinder, four-stroke, in-line diesel engine with direct injection, oil/air cooling and externally controlled exhaust gas recirculation (EGR).

The engine data plate specifies model, engine number and power data. The engine number is also stamped into the crankcase. Model and engine number must be specified when ordering spare parts. The direction of rotation is found on the flywheel, anticlockwise. Firing order: 1-3-4-2 (cylinder no. 1 on the flywheel side).

**IMPORTANT! Adjustments to the regulator may only be performed by trained staff in an authorized central repair workshop.**

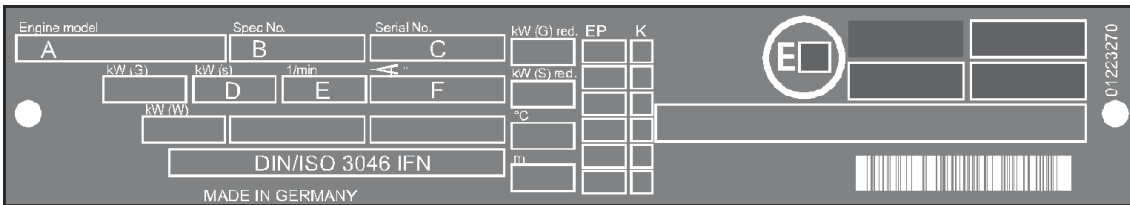

V1044195

**Figure 1**  
**Engine data plate up to SN 1753000**

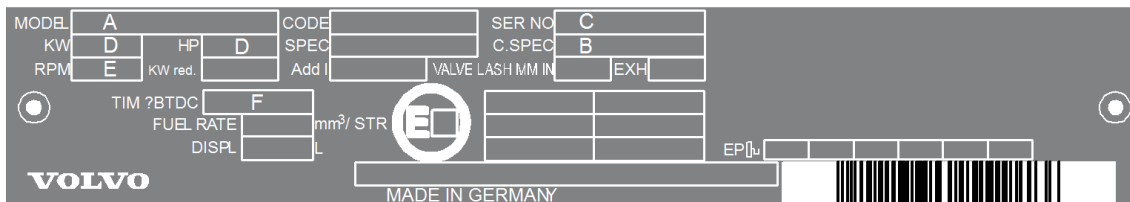

V1044234

**Figure 2**  
**Engine data plate from SN 1753001**

- A. Engine type
- B. Spare part number
- C. Engine number
- D. Capacity
- E. Rated speed
- F. Timing setting

### Components, servicing view

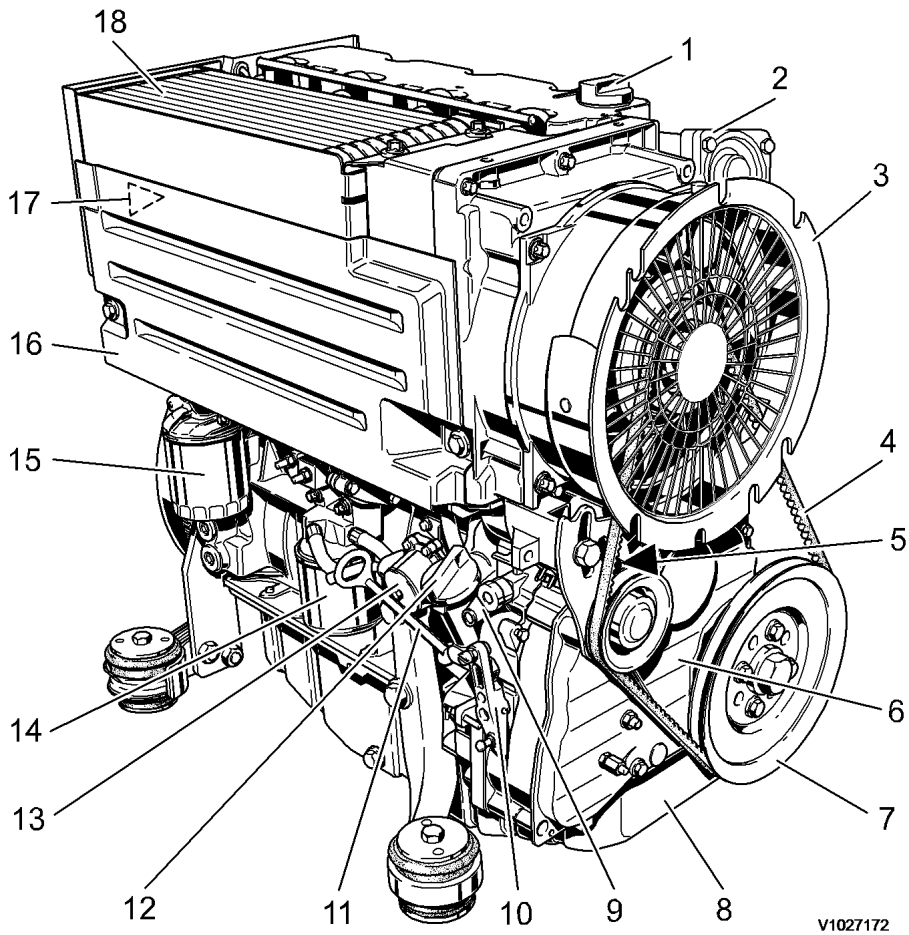

**Figure 3**  
**Components, servicing view**

1. Oil filler port (valve cover)
2. Air inlet pipe
3. Fan with integrated alternator
4. V-rib belt
5. Engine stop solenoid
6. Gear housing cover, timing belt cover
7. V-belt roller, crankshaft
8. Oil sump
9. Start/stop lever
10. Engine speed adjustment
11. Oil dipstick
12. Oil filler pipe
13. Fuel pump
14. Fuel filter
15. Oil filter
16. Cooling air baffle
17. Injection pumps
18. Oil cooler

**Components, exhaust view**

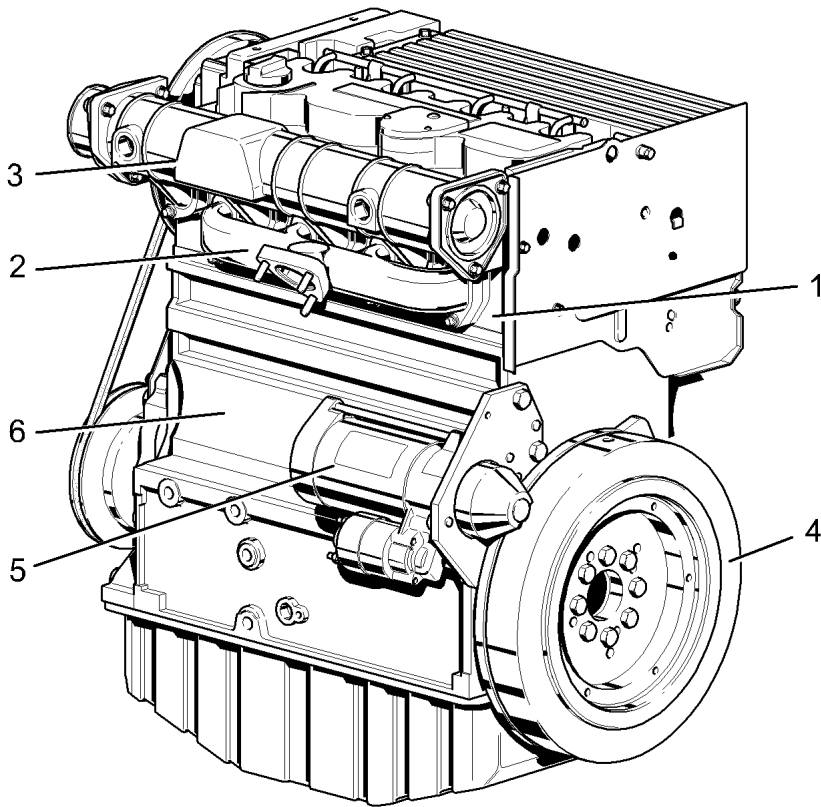

V1027173

**Figure 4**  
**Components, exhaust view**

1. Cylinder head
2. Exhaust manifold
3. Air inlet pipe
4. Flywheel
5. Starter
6. Crankcase

#### **Exhaust gas recirculation (EGR)**

In order to comply with emission limits, the engine is equipped with an externally controlled exhaust gas recirculation system, which directs some of the exhaust gas back into the combustion air. The oxygen content of this exhaust gas is low, which serves to lower the peak combustion temperature, thereby reducing generation of nitrogen oxides (NO<sub>x</sub>).

The exhaust gas required for recirculation is directed from the cylinders via a line system and travels through the EGR valve via the exhaust induction port directly into the inlet ports of the cylinder head, where it is re-aspirated by the engine.

The EGR valve is active when the load is between 0 and 75%. If the load is greater than 75%, the EGR valve remains closed to prevent oxygen deficiency through high smoke formation.

The EGR valve is controlled via a control rod displacement sensor. An LED on the control rod displacement sensor indicates the status of the exhaust gas recirculation system. The LED is lit when the system is active.

The control rod displacement sensor and EGR valve are supplied power via connector x40 (stop solenoid Y6).

Oil from rocker arm lubrication is used to cool the EGR valve. This oil travels back to the oil sump via the oil return system.

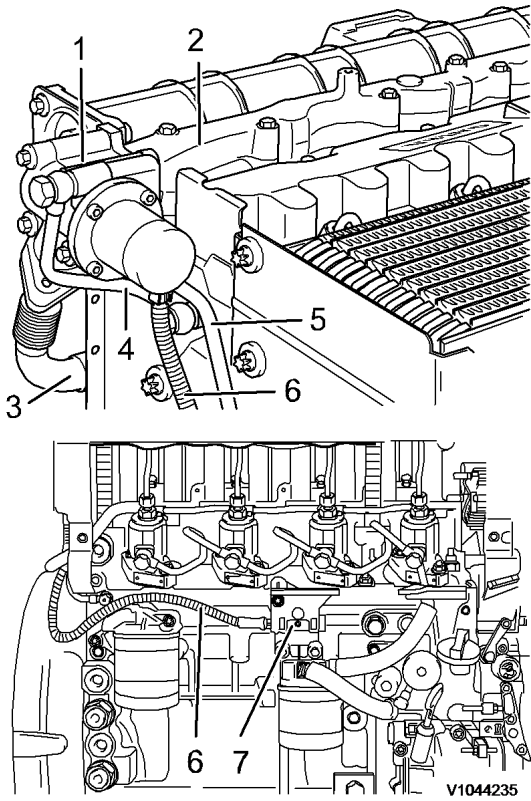

**Figure 5**  
**Externally controlled exhaust gas recirculation**

1. EGR valve
2. Exhaust induction port
3. Exhaust supply
4. Lubrication oil from cooling taken from rocker arm lubrication
5. Lubrication oil return to oil sump
6. Electrical cable for control rod displacement sensor
7. Control rod displacement sensor

Document Title: <b>Engine, removing</b>	Function Group: <b>210</b>	Information Type: <b>Service Information</b>	Date: <b>2014/3/8 0</b>
Profile: <b>CWL, L25B [GB]</b>			

## Engine, removing

### Op nbr 210-070

1. Place the machine in service position.
2. Switch off the battery disconnect switch and disconnect the positive battery terminal.



### **WARNING**

**The work involves handling heavy components - failure to stay alert may result in severe crushing injuries.**

3. Open the engine hood and unscrew the fixing bolts.
4. Lift off the engine hood and place it on a suitable surface.
5. Remove the air flow guide plate (1).

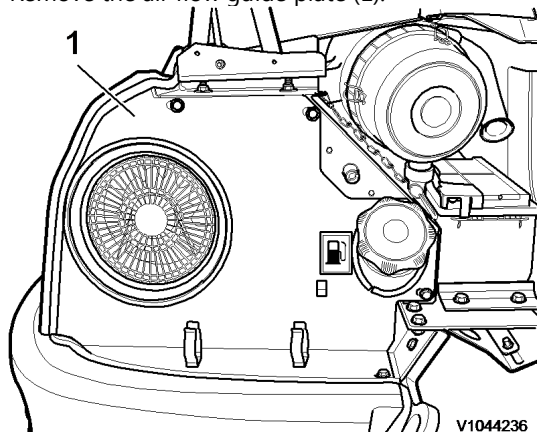

**Figure 1**

6. Disconnect the pin plug connection of the tail lights.
7. Detach the engine hood catch (1) at the counterweight.

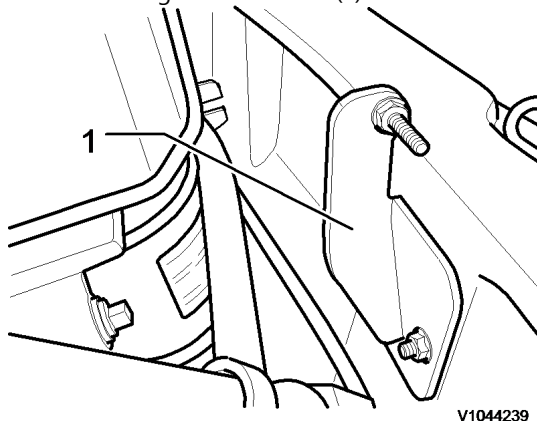

**Figure 2**

8. Attach a lifting device (E-tool) to the counterweight and suspend it from the crane using suitable hoisting equipment.

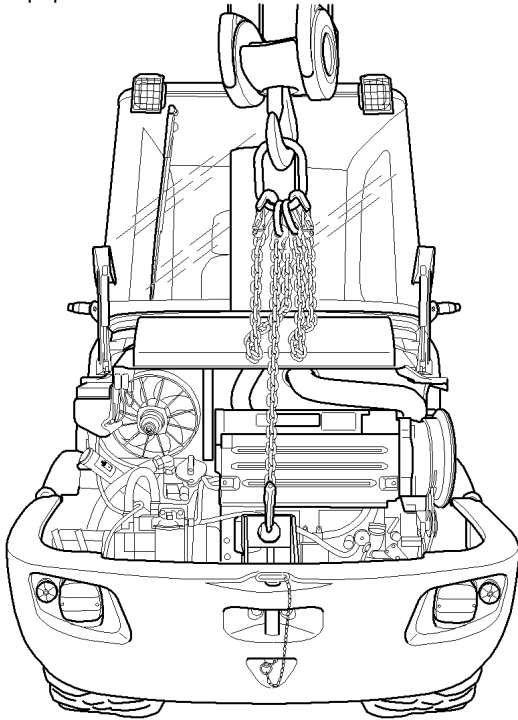

V1044240

**Figure 3**

9. Remove the counterweight retaining bracket (arrows).

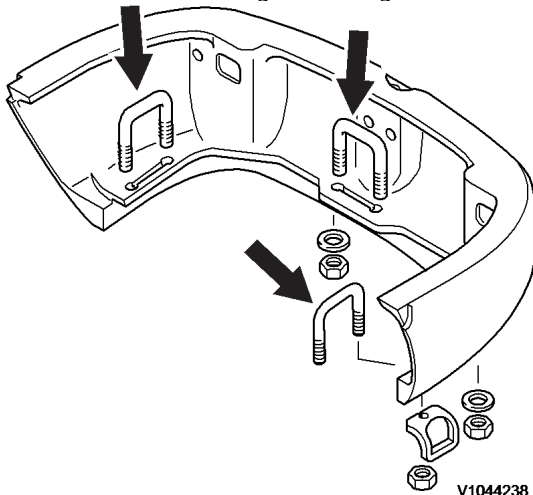

V1044238

**Figure 4**

10. Slowly raise the counterweight and remove towards the rear.

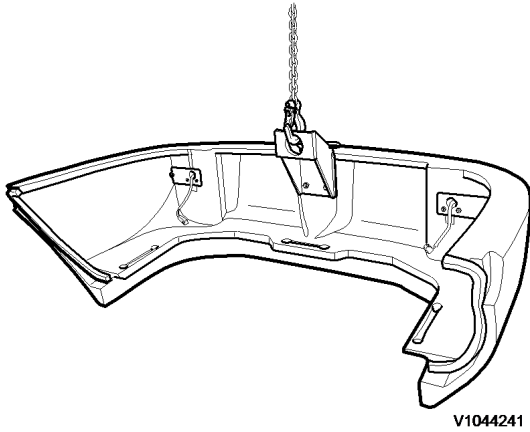
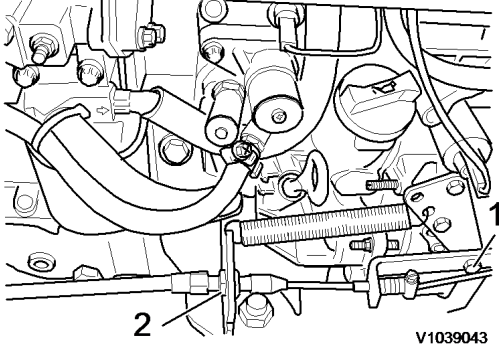

**Figure 5**

**NOTE!**

Lower the counterweight onto a suitable surface.

11. Detach the throttle cable from the engine. Unscrew the bracket (1) and slacken the jam nuts (2).



**Figure 6**

12. Remove heater connections (1) and (2) and seal with plugs.

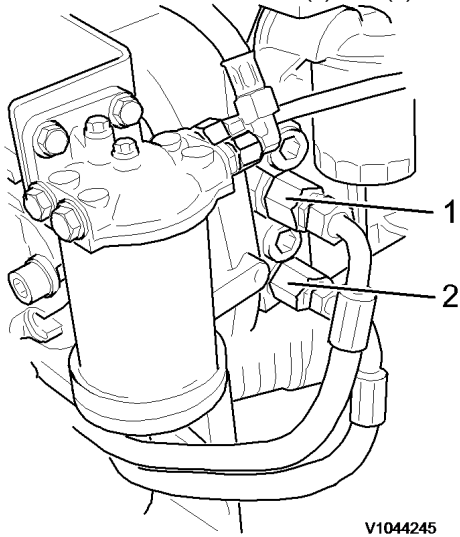
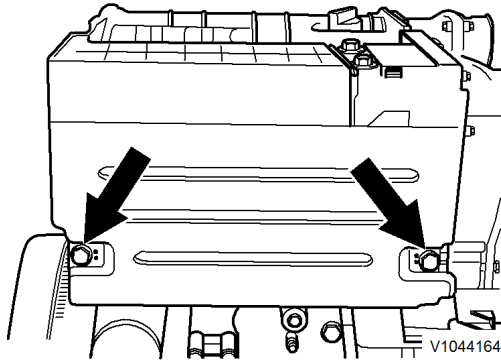

**Figure 7**

**NOTE!**

Mark supply and return.

13. Remove air duct cover



**Figure 8**

14. Undo the hose clamp with clamping tongs and detach the fuel return hose (1).

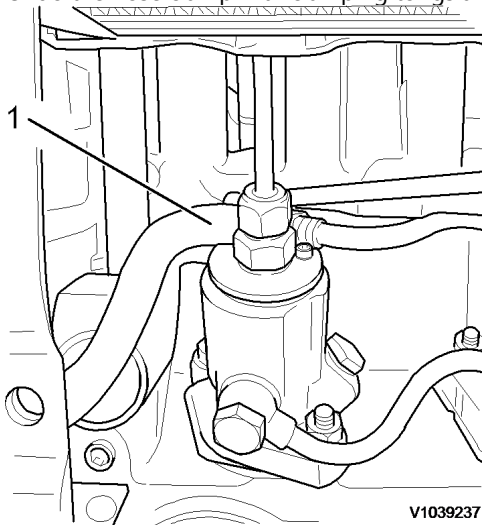
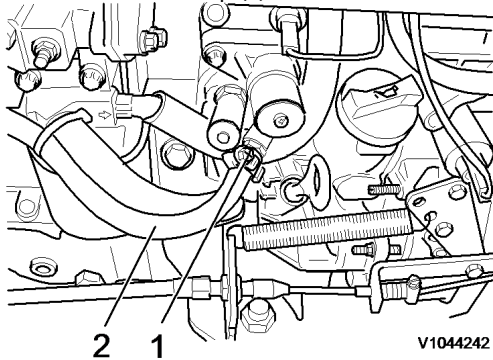

**Figure 9**

### **NOTICE**

**When a hose has been disconnected, plug both the hose and the connection immediately. The hoses should be marked for correct connection.**

15. Undo the hose clamp (1) and detach the fuel hose (2) from the fuel pump.



**Figure 10**

16. Unscrew the bolt (1) at the connection flange and remove the bracket (2) with the fuel filter/water separator assembly.



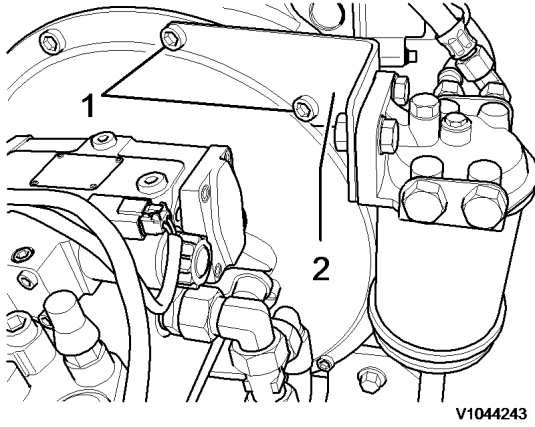

V1044243

**Figure 11**

17. Unscrew the remaining bolts at the connection flange.

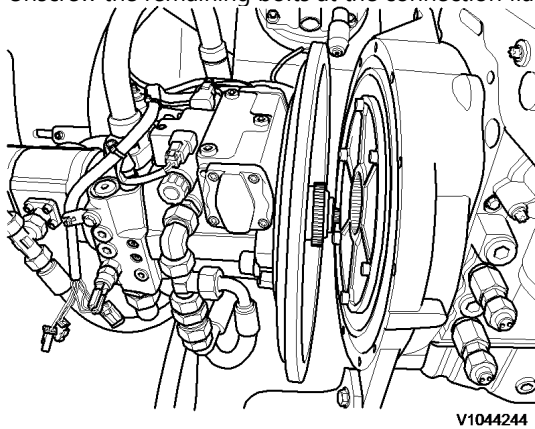

V1044244

**Figure 12**

18. Suspend the hydraulic variable displacement pump from a crane using suitable hoisting equipment and pull it out of the connection housing. Support the hydraulic variable displacement pump and put it aside.
19. Remove the flexi exhaust pipe from the silencer.

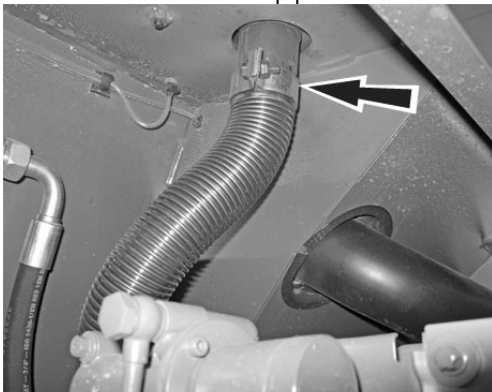

V1038860

**Figure 13**

20. Disconnect the connection cable (1) from the air filter control switch.

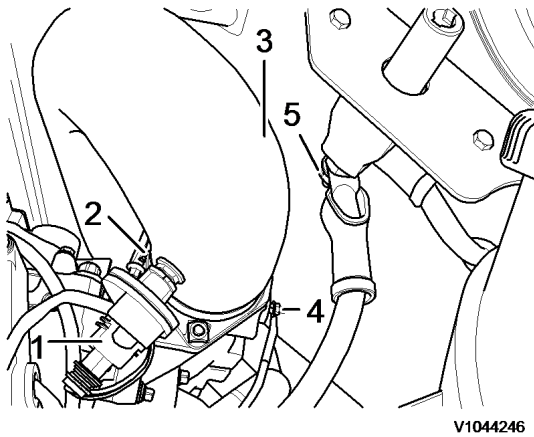

**Figure 14**

21. Release clamp (2) on air filter intake hose and pull hose (3) off air inlet pipe.
22. Unscrew the glow plug connection cable (4).
23. Unscrew the ground connection (5) from the battery disconnect switch.
24. Disconnect electrical pin plug connection X24 (fuel tank sensor) and X26 (engine connection).

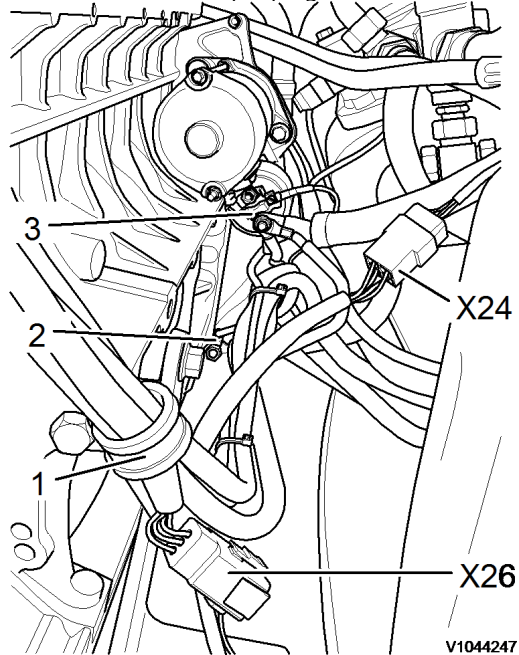

**Figure 15**

25. Undo clamp (1) and remove cable tie.
26. Remove ground connection (2) at engine block.
27. Disconnect charging current line (B+) to starter (3).
28. Remove engine bracket fixing bolts at frame.

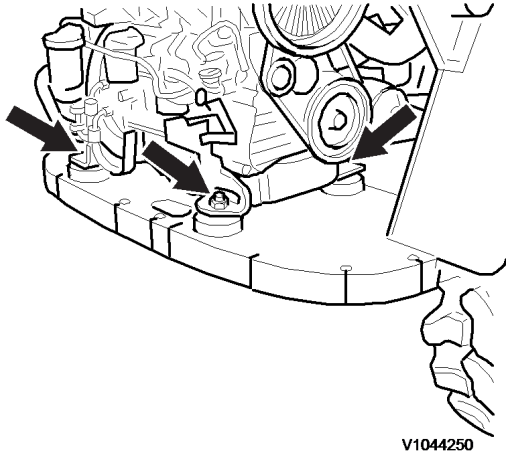

**Figure 16**

29. Fasten a lifting device (E-tool) to the engine and suspend from the crane.

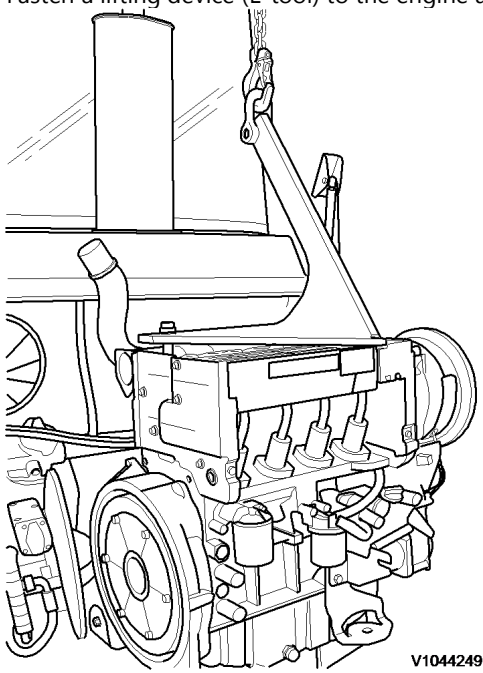

**Figure 17**

30. Slowly out the engine and place it on a suitable surface.

Document Title: <b>Engine, installing</b>	Function Group: <b>210</b>	Information Type: <b>Service Information</b>	Date: <b>2014/3/8 0</b>
Profile: <b>CWL, L25B [GB]</b>			

## Engine, installing

Op nbr 210-072

### **! WARNING**

The work involves handling heavy components - failure to stay alert may result in severe crushing injuries.

1. Fasten a lifting device (E-tool) to the engine and suspend from the crane.

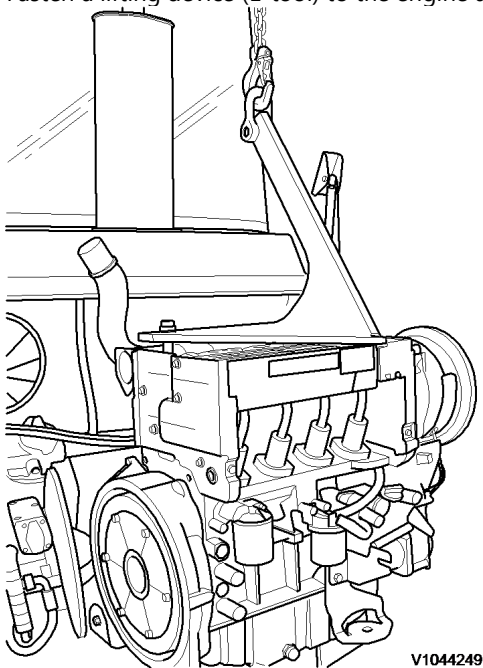
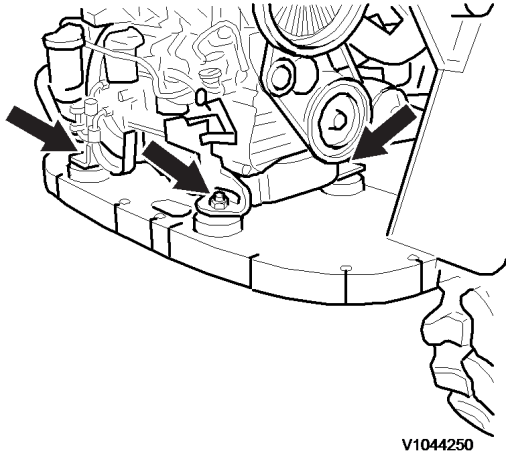

**Figure 1**

2. Slowly lower the engine into the engine bay and position on the engine mounts.

### **NOTICE**

**Make sure that no hoses or cables are trapped.**



V1044250

**Figure 2**

3. Tighten the engine bracket fixing bolts to the frame. Tightening torque **200 Nm (148 lbf ft)**.
4. Unhook the lifting device and unscrew from the engine.
5. Connect electrical pin plug connection X24 (fuel tank sensor) and X26 (engine connection).

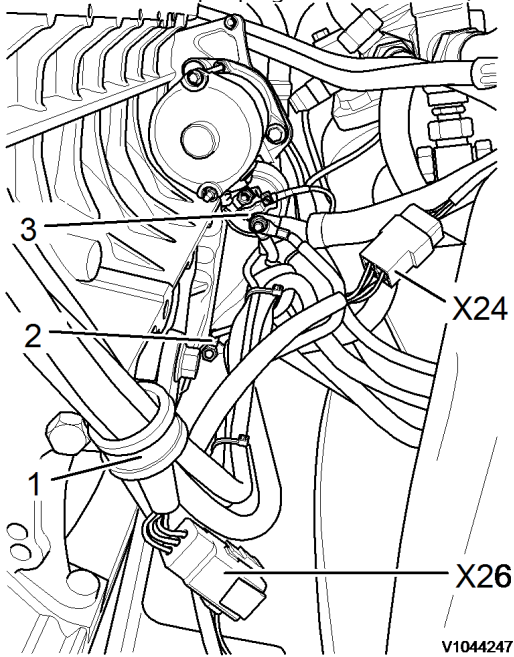

V1044247

**Figure 3**

6. Install ground connection (2) at engine block.
7. Attach charging current line (B+) to the starter (3).
8. Screw in clamp (1) and fit cable tie.
9. Attach intake hose (3) to the air inlet pipe and fasten with the clamp (2).

**Buy Now**



Our support email:

[ebooklibonline@outlook.com](mailto:ebooklibonline@outlook.com)