

# 55A, 55B and 55H Three-Bottom Drawn Moldboard Plows



## OPERATORS MANUAL 55A, 55B and 55H Three-Bottom Drawn Moldboard Plows

OMA41258 (01DEC58) English

**OMA41258 (01DEC58)**

LITHO IN U.S.A.  
ENGLISH



## YOUR NEW PLOW

Behind your new plow is an organization that has specialized in designing and building plows for over one hundred and twenty years. This plow was built in the world's largest plow factory by experienced men, many who have worked in this large plant for from ten to forty-five years, thus assuring the utmost in good design, high-grade workmanship and thorough inspection, so essential to the production of good plows.

High quality materials, precision production methods, and accurately controlled heat-treating assure maximum strength and long life for every part.

This manual has been carefully prepared and illustrated, so that you may make the necessary adjustments for adapting your plow to work properly in practically all types of soil and field conditions. These adjustments such as proper hitching and adjusting for width and depth of cut, are fully covered in this manual.

Study this manual carefully. Keep it handy, in a safe place, for future reference.



Occasionally your plow may need new parts, or require service not covered in this manual. If so, we suggest that you take advantage of the facilities offered by your John Deere dealer, which assure you of genuine JOHN DEERE Parts and prompt "know-how" service in the field or shop.

If you will furnish your dealer with the information which should be recorded at the bottom of this page, when the plow is delivered, he can give you prompt and efficient service.

### JOHN DEERE 55A, 55B, AND 55H MOLDBOARD PLOWS

55A ||

55B ||

55H ||

Date Purchased ..... 19.....

*(To be filled in by Purchaser)*

## TABLE OF CONTENTS

	<i>Page</i>
IDENTIFICATION VIEWS.....	2-3
SPECIFICATIONS.....	4-5
OPERATING AND ADJUSTING INSTRUCTIONS.....	6-25
Importance of Proper Adjustment.....	6
Preparing the Plow.....	6
Preparing and Adjusting Tractor.....	7
Hitching Plow to Tractor.....	8-11
Types of Hitches.....	11-12
Mechanical Control.....	13
Hydraulic Control.....	13-14
Leveling.....	15
Depth of Plowing.....	16
Lifting Springs.....	16
Rear Axle, Wheel, and Lift Rod.....	17
Rolling Coulters.....	18-19
Jointers.....	20
Landing Lever.....	21
Moldboard Pad.....	21
Root Cutter.....	22
Weed Hooks.....	22
Transporting.....	23
Safety Suggestions.....	23
PROCEDURE FOR FIELD ADJUSTING PLOW.....	24-25
MAINTENANCE SUGGESTIONS.....	26-28
LUBRICATING INSTRUCTIONS.....	30
PLOWING DIFFICULTIES AND REMEDIES.....	31-34
SETTING-UP INSTRUCTIONS.....	35-51
SHIPPING BUNDLES.....	35-37

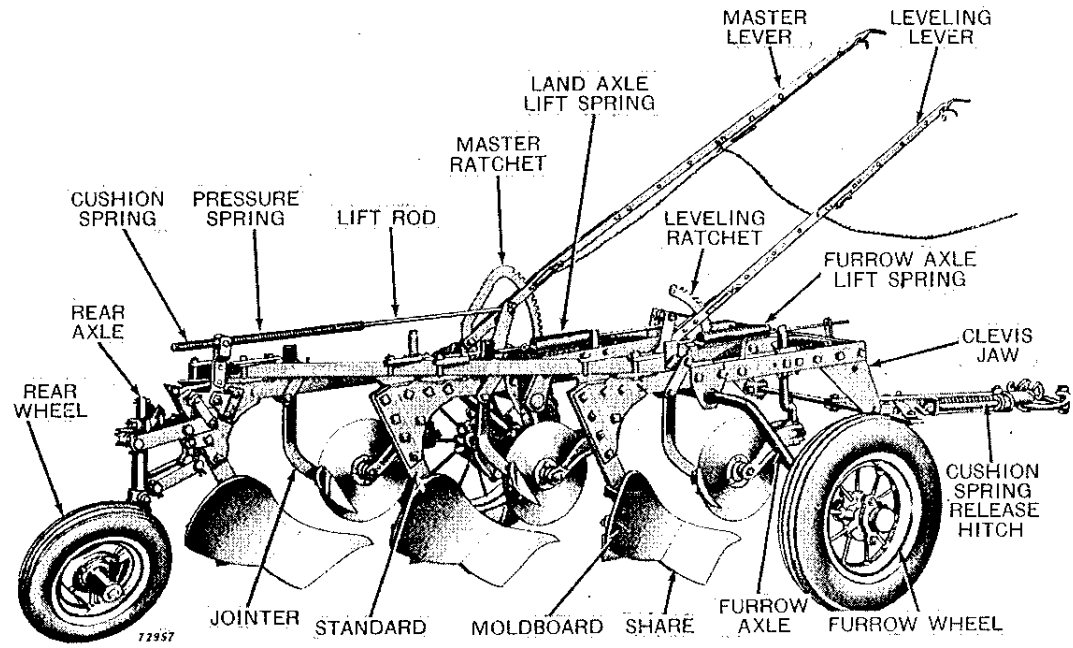

*John Deere 55B—3-Bottom Tractor Plow*

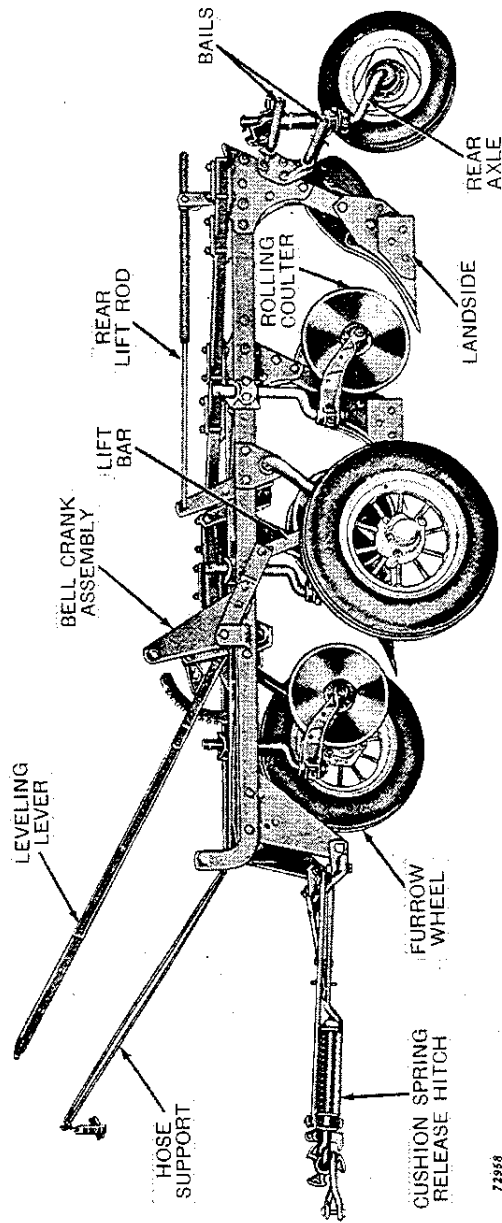

72358

*John Deere 55H Three-Bottom Tractor Plow—Landside View*

## SPECIFICATIONS

**Types**—The 55 Series Plows are furnished in the following types and sizes:

55A Three-Bottom Rice Plow, 12-Inch and 14-Inch Frames.

55B Three-Bottom Plow, 12-Inch, 14-Inch, and 16-Inch Frames.

55H Three-Bottom Powr-Trol Plow, 12-Inch, 14-Inch, and 16-Inch Frames.

**Depth Range**—3 to 12 inches, depending on type and size of bottom.

**Bottoms**—As ordered. Various types and sizes available.

**Wheels—Furrow:**

55A—Wheel without 5:90 x 15 Tire and Tube, Regular  
 Wheel with 5:90 x 15 Tire and Tube, Special  
 26 x 4 Steel, Special  
 26 x 6 Steel, Special

55B—Wheel without 5:90 x 15 Tire and Tube, Regular  
 Wheel with 5:90 x 15 Tire and Tube, Special  
 26 x 4 Steel, Special  
 26 x 6 Steel, Special

55H—Wheel without 5:90 x 15 Tire and Tube, Regular  
 Wheel with 5:90 x 15 Tire and Tube, Special  
 26 x 4 Steel, Special  
 26 x 6 Steel, Special

**Land:**

55A—Wheel without 7:60 x 15 Tire and Tube, Regular  
 Wheel with 7:60 x 15 Tire and Tube, Special  
 32 x 8 Steel, Special  
 32 x 6 Steel, Special

55B—Wheel without 6:40 x 15 Tire and Tube, Regular  
 Wheel with 6:40 x 15 Tire and Tube, Special  
 26 x 6 Steel, Special

55H—Wheel without 5:90 x 15 Tire and Tube, Regular  
 Wheel with 5:90 x 15 Tire and Tube, Special  
 26 x 4 Steel, Special  
 26 x 6 Steel, Special

**Rear**—55A, 55B, and 55H—Wheel with 4:00 x 12 Tire and Tube, Regular  
 Wheel without 4:00 x 12 Tire and Tube, Special  
 19-Inch x 3-1/2-Inch Steel Convex Disk, Special

---

## **SPECIFICATIONS—Continued**

**Hitch**—55A, 55B, and 55H

Cushion Spring Release, Regular

Cushion, Special

**Lift**—Enclosed Type Clutch for 55A and 55B

Hydraulic Remote Cylinder for 55H

**Levers**—Adjustable for length.

**Coulters**—17-Inch, Plain—Regular

15-Inch, Plain—Special

17-Inch, Notched—Special

18-Inch, Plain—Special

**Jointers**—Steel or Cast Independent—Available when ordered.

Steel or Cast Combination—Available when ordered.

**Root Cutters**—Special

**Moldboard Pads**—Special

**Weed Hooks**—Special

*(Specifications and design subject to change without notice.)*

*NOTE: When terms "right" or "left" are used, it means from a position behind the plow and looking toward the front.*

## OPERATING AND ADJUSTING INSTRUCTIONS

### IMPORTANCE OF PROPER ADJUSTMENT

Your new plow is fully adjustable and, when properly adjusted to operate in the type of soil and field conditions on your farm, it will do a good job of plowing at a minimum of expense. A well-adjusted plow pulls lighter; its furrow slices are uniform

in width and depth; it covers trash; it leaves the soil in proper condition to be worked down into the best type seedbed.

Improper adjustment results in rapid wear and possible breakage of parts, and inefficient operation.

### PREPARING THE PLOW

#### BOTTOMS AND COULTERS

The polished surfaces of the plow bottoms and coulters have been painted with protective black paint.

In most cases it is not necessary to remove the black paint because it will wear off quickly upon contact with the soil. In those soils where the black paint will not wear off, remove with gasoline, kerosene, or diesel fuel.

If the plow is not to be used immediately, protect the polished surfaces by applying a coat of cup or gun grease. If plow is to be put in storage for a considerable length of time, see pages 26 and 28.

#### TIRE INFLATION

Check plow tires to be sure they are inflated properly as shown below:

<i>Wheel</i>	<i>Recommended New Implement or New Used Auto Tires</i>	<i>Inflation Pressure</i>
Furrow	5.90 x 15—4-Ply	28 Lbs.
and	5.90 x 15—4-Ply	28 Lbs.
Land	6.40 x 15—4-Ply	24 Lbs.
	7.60 x 15—4-Ply	24 Lbs.
Rear	4.00 x 12—4-Ply	36 Lbs.

#### LUBRICATION

Be sure plow has been properly lubricated. See Lubrication Chart on page 30.

#### BOLTS AND SET SCREWS

Before starting to work with a new plow or one which has been stored, check to see that all bolts and set screws are tight and all cotter pins spread to keep them from falling out. Check the bolts that hold the plow bottoms to see that they are drawn up very tight.

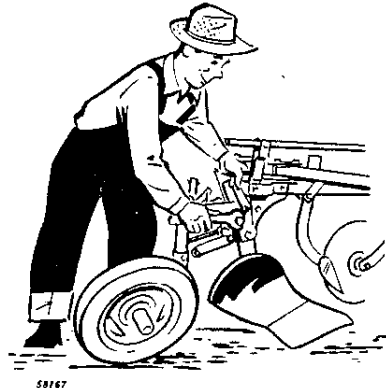

A good practice is to check for loose bolts, screws, or parts when lubricating the plow. Loose bolts are easily lost or cause excessive wear on parts, resulting in possible serious damage to the plow.



## PREPARING AND ADJUSTING TRACTOR

For complete tractor operating instructions, refer to your tractor Operator's Manual.

### TIRE INFLATION

Inflate the tractor tires as recommended in the tractor Operator's Manual. For plowing, add 4 pounds more air in right rear tire than in left rear tire.

Proper air pressure is the most important factor in satisfactory performance and maintenance of tractor and implement tires. Underinflation will damage the cord body of the tire and cause a series of radial breaks in the sidewall fabric. This may occur on the inner sidewall of the furrow wheel tire. If the tire buckles or wrinkles, the air pressure should be increased to where the sidewalls remain smooth while operating.

If additional traction is required, add weight to the wheels. Lowering the air pressure will make little difference in the traction and may ruin the tires.

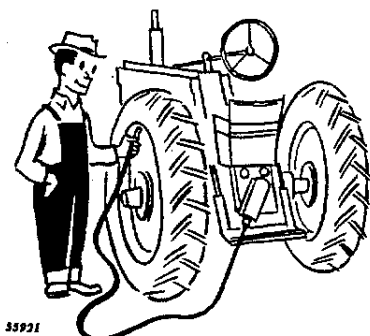

Check air pressures every two or three weeks. Use a special low pressure gauge having 1-pound graduations.

### REAR WHEEL WEIGHTING

In average conditions, rear wheel weights are not necessary. In those conditions where it becomes necessary to add weight to the rear wheels, see your tractor Operator's Manual for weighting instructions.

Power can be lost and tire life cut drastically by wheel slippage. Adding weight also serves to stabilize the tractor when plowing in rough or hillside fields.

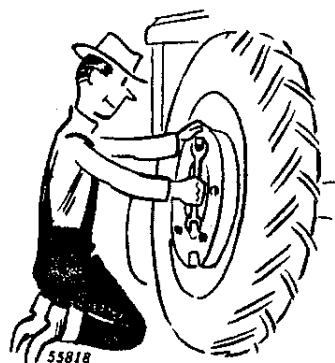

### TRACTOR DRAWBAR

On wheel-type tractors, set the tractor drawbar in the **short high position** and, except where off-hitching is required, bolt it exactly in the center of tractor, midway between rear wheels.

### REAR WHEEL SETTING

Tractor rear wheel settings are determined by the location of the center line of draft in the plow. Therefore, it is necessary to first read "Hitching Plow to Tractor" on the following pages. Then adjust the wheels as explained on page 9.

### FRONT WHEEL SETTINGS

On wide-front-end tractors, set front wheels to conform to rear wheel setting, center-to-center of tread.

## HITCHING PLOW TO TRACTOR

The ideal hitch is a straight line from the center point of pull on the tractor to the center point of resistance on the plow, both horizontally and vertically.

The center point of pull on the tractor is located approximately 3 inches ahead of the rear axle housing and midway between the rear wheels.

To find the center point of resistance on the plow, first find the center line of draft as explained below.

### CENTER LINE OF DRAFT

The center line of draft is simply an imaginary line drawn from the point of pull on the tractor to the point of resistance on the plow.

The center line of draft of the plow can be located by using the following rule:

**Rule:** The center line of draft of a moldboard plow is located at a point one-fourth of the cutting width of one bottom measured to the left of the center of total cut of the plow. (This rule applies to all plows whether one-, two-, three-, four-, or five-bottom.)

**Example:** Finding center line of

draft of a three-bottom 14-inch plow; Total cut of plow = 42 inches.

Center of cut or one-half of 42 inches = 21 inches.

One-fourth the cutting width of one-bottom = 3-1/2 inches.

3-1/2 inches added to center of cut, which is 21 inches = 24-1/2 inches.

Therefore, the center line of draft of a three-bottom 14-inch plow is 24-1/2 inches measured to the left and at right angles from the furrow wall. See illustration below.

### CENTER POINT OF RESISTANCE

The center point of resistance on a plow is located on the bottom intersected by the line of draft, at a point approximately one-half of the plowing depth from the bottom of the furrow. When plowing 6 inches deep, the point of resistance will be 3 inches up from the furrow bottom, or approximately at the junction of the share and moldboard. If plowing deeper than 6 inches, this point will be located farther up on the moldboard. If plowing shallower than 6 inches, the point of resistance will be farther down on the share.

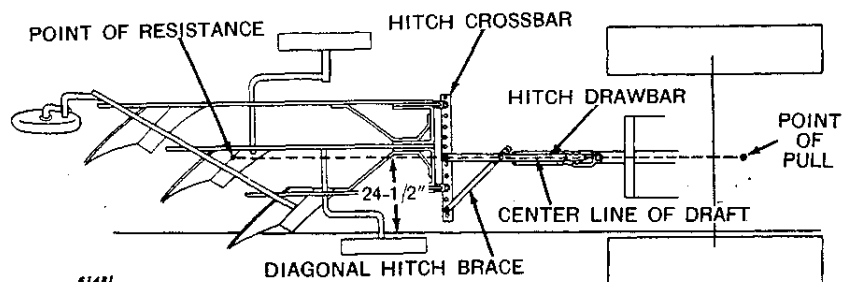

61481  
*Horizontal Hitch Adjustments on Three-Bottom, 14-Inch Plow*

Thank you so much for reading.  
Please click the “Buy Now!”  
button below to download the  
complete manual.



After you pay.

You can download the most  
perfect and complete manual in  
the world immediately.

Our support email:

[ebooklibonline@outlook.com](mailto:ebooklibonline@outlook.com)