

JOHN DEERE
WORLDWIDE COMMERCIAL & CONSUMER
EQUIPMENT DIVISION

Snow Blade
46 Inch

SN (NA)

OMGX20517 A9

OPERATOR'S MANUAL



JOHN DEERE

All information, illustrations and specifications in this manual are based on the latest information at the time of publication. The right is reserved to make changes at any time without notice.

COPYRIGHT© 2009
Deere & Co.

John Deere Worldwide Commercial and Consumer Equipment Division

All rights reserved
Previous Editions

COPYRIGHT© 1999, 2003, 2004, 2007

North American Version
Litho in U.S.A.

INTRODUCTION

Introduction

Using Your Operator's Manual

Read this entire operator's manual, especially the safety information, before operating.

This manual is an important part of your machine. Keep all manuals in a convenient location so they can be accessed easily.

Use the safety and operating information in the attachment operator's manual, along with the machine operator's manual, to operate and service the attachment safely and correctly.

If your attachment manual has a section called Preparing the Machine, it means that you will have to do something to your tractor or vehicle before you can install the attachment. The Assembly and Installation sections of this manual provide information to assemble and install the attachment to your tractor or vehicle. Use the Service section to make any needed adjustments and routine service to your attachment.

If you have any questions or concerns with the assembly, installation, or operation of this attachment, see your local John Deere dealer or call the John Deere Customer Contact Center at 1-800-537-8233 for assistance.

Warranty information on this John Deere attachment can be found in the warranty that came with your John Deere tractor or vehicle.

Product Identification

Product Compatibility

The 46-Inch Snow Blade is compatible with Lawn Tractors.

Record Purchase Information

Record your purchase information in spaces provided below.

DATE OF PURCHASE:

DEALER NAME:

DEALER PHONE:

Safety

Read Safety in Machine Operator's Manual

Read the general safety operating precautions in your machine operator's manual for additional safety information.

Operating Safely

- This attachment is intended for light duty moving of snow or other light, loose material. Do not misuse this equipment.
- Read, understand and follow all instructions in the manual and on the vehicle and attachment before operating.
- Only allow responsible adults who are familiar with the instructions to operate the machine.
- Inspect machine and attachment before you operate. Be sure hardware is tight. Repair or replace damaged, badly worn or missing parts. Be sure guards and shields are in good condition and fastened in place. Make any necessary adjustments before you operate.
- Check brake action before you operate. Adjust or service brakes as necessary.

- Stop machine if anyone enters the area.
- If you hit an object, stop and inspect the machine. Make repairs before you operate. Keep machine and attachments properly maintained and in good working order.
- Before operating, make sure all connections are tight and blade responds properly to controls. Check all connections periodically for tightness.
- Do not leave machine unattended when it is running.
- Only operate during daylight or with good artificial light.
- Be careful of traffic when operating near or crossing roadways.
- Do not wear radio or music headphones while operating the machine. Safe operation requires your full attention.
- Transport the blade with it raised to the highest position.
- Be aware of the position of the blade ends. Blade makes a wide arc when turning.
- Be aware of the possibility of objects hidden under the snow. Avoid holes, rocks, roots and other obstructions.
- Avoid the edges of ditches and banks to reduce the possibility of loss of control.
- When plowing material into a pile, travel in reverse before raising blade.
- Do not ram into a pile of material; slow down before contact is made.
- Lower attachment completely before leaving operator's seat.
- Lower any attachment completely to the ground or to an existing attachment mechanical stop before servicing the attachment. Disengage all power and stop the engine. Lock park brake and remove the key.
- Keep all parts in good condition and properly installed. Fix damage immediately. Replace worn or broken parts. Replace all worn or damaged safety and instruction decals.

Parking Safely

1. Stop machine on a level surface, not on a slope.
2. Lower attachments to the ground.
3. Lock the park brake.
4. Stop the engine.
5. Remove the key.
6. Wait for engine and all moving parts to stop before you leave the operator's seat.
7. Close fuel shut-off valve, if your machine is equipped.
8. Disconnect the negative battery cable or remove the spark plug wire (for gasoline engines) before servicing the machine.

Checking Area to be Cleared

- Thoroughly inspect the area where the equipment is to be used and remove all doormats, sleds, boards, wires and other foreign objects.
- Keep people and pets out of the work area. Keep children indoors when using blade. Turn the machine off if anyone enters the area.
- Be extremely careful if you must clear snow from a gravel surface. Adjust the blade height to clear a gravel surface.

Avoid Injury From Hitting Obstructions

- Raise attachment when you drive between jobs.
- Slow down when you remove snow. Be cautious on slopes, when you make turns or when close to buildings or trees.

ASSEMBLY

Assembly

Identify Parts

Parts in Kit

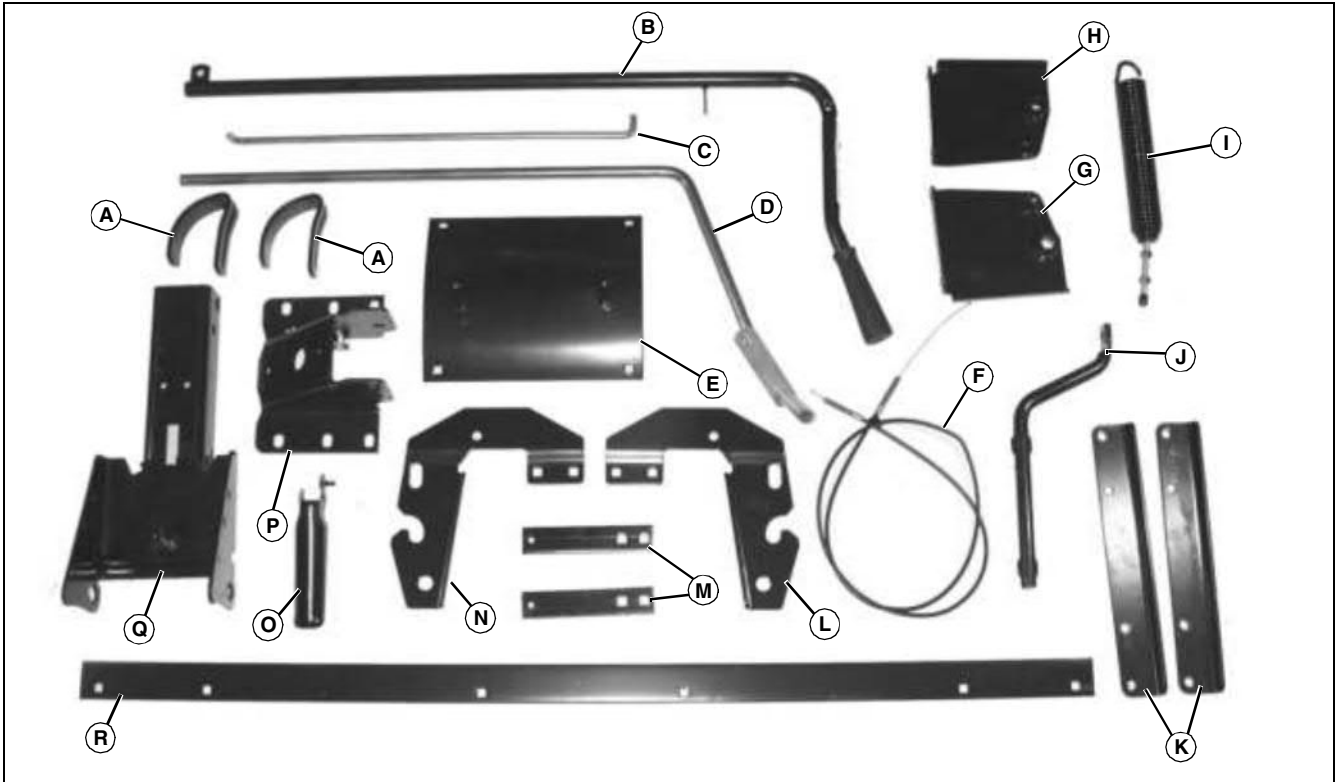

MX10403a

Key	Description	Qty
A	Skid Shoe	2
B	Lift Handle Tube	1
C	Blade Pivot Rod	1
D	Lift Handle Rod	1
E	Reinforcement Plate	1
F	Control Cable	1
G	Right Hitch Plate	1
H	Left Hitch Plate	1
I	Trip Spring	1
J	Blade Pivot Shaft	1
K	Angle Support Bracket	2
L	Right Mounting Bracket	1
M	Angle Lock Bar	2
N	Left Mounting Bracket	1

O	Release Grip	1
P	Pivot Support Bracket	1
Q	Push Channel Assembly	1
R	Scraper Plate	1
	Blade (Not Shown)	1

ASSEMBLY

Bag of Parts

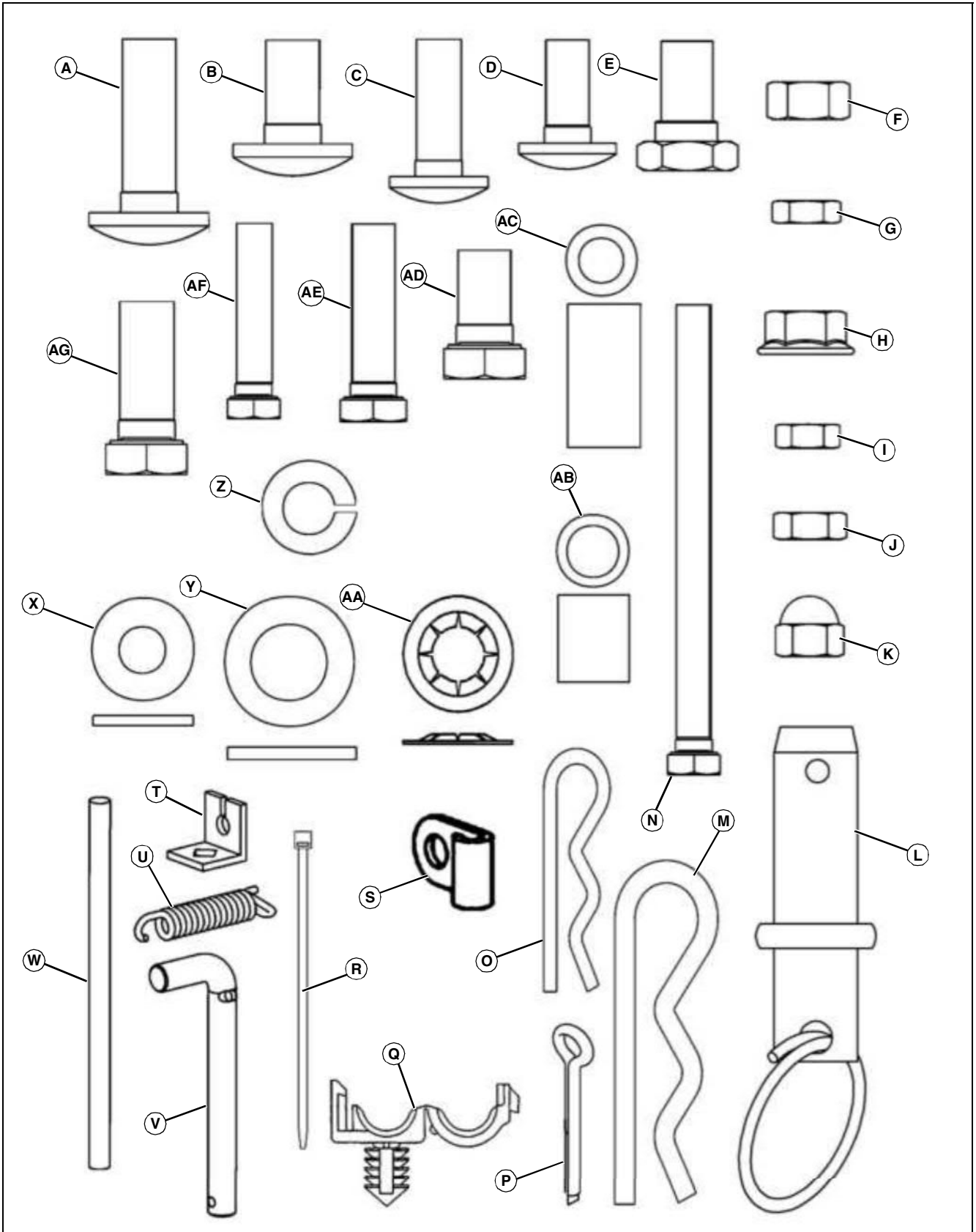

MX42096

ASSEMBLY

Key	Description	Qty
A	Carriage Bolt, 3/8 X 1-1/4 in.	2
B	Carriage Bolt, 3/8 X 3/4 in.	4
C	Carriage Bolt, 5/16 X 1 in.	2
D	Carriage Bolt, 5/16 X 3/4 in.	8
E	Shoulder Bolt, 3/8 X 5/8 in.	2
F	Nut (Regular), 3/8 in.	2
G	Jam Nut, 5/16 in.	2
H	Lock Nut, Flanged, 3/8 in.	16
I	Lock Nut, 1/4 in.	2
J	Lock Nut, 5/16 in.	11
K	Acorn Nut, 1/4 in.	1
L	Clevis Pin, 5/8 X 1-1/2 in.	2
M	Spring Locking Pin, 1/8 in.	2
N	Hex Bolt, 1/4 X 3-1/4 in.	1
O	Spring Locking Pin, 3/32 in.	4
P	Cotter Pin, 1/8 in.	2
Q	Conduit Clip	1
R	Tie Strap	2
S	Clevis Lanyard Fitting	2
T	Cable Mount Bracket	1
U	Extension Spring	1
V	Channel Pivot Pin	1
W	Spring Mount Rod	1
X	Washer, 5/16 in.	4
Y	Washer, 17/32 in.	4
Z	Lock Washer, 3/8 in.	2
AA	Palnut, 3/8 in.	2
AB	Spacer, 0.39 ID X 0.62 in.	1
AC	Spacer, 0.28 ID X 0.95 in.	2
AD	Hex Bolt, 3/8 X 3/4 in.	2
AE	Hex Bolt, 5/16 X 1-1/4 in.	1
AF	Hex Bolt, 1/4 X 1-1/4 in.	1
AG	Hex Bolt, 3/8 X 1 in.	8
	Grease Tube (Not Shown)	1
	Plastic Grip, Black (Not Shown)	1

Attach Parts to Blade

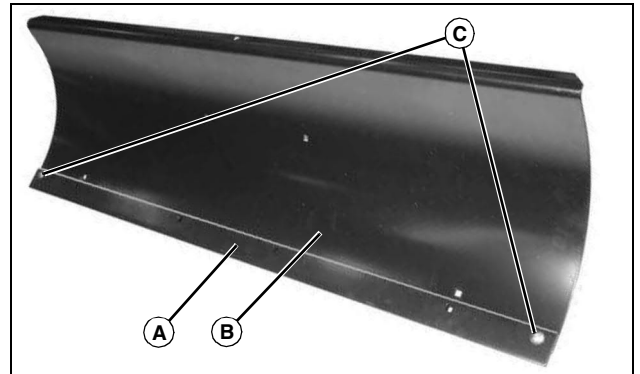

MX10407

1. Attach scraper plate (A) to front of blade (B) using two 5/16X3/4 in. carriage bolts and 5/16 in. lock nuts (C).

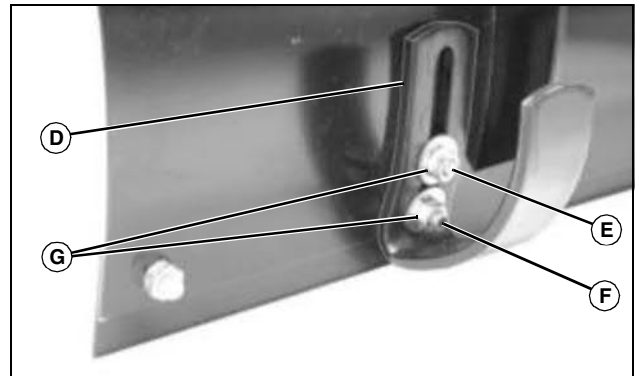

MX10442

2. Attach two skid shoes (D) to rear of blade using two 5/16X3/4 in. carriage bolts (E), two 5/16X1 in. carriage bolts (F), four 5/16 in. washers (X) and four 5/16 in. lock nuts (G).

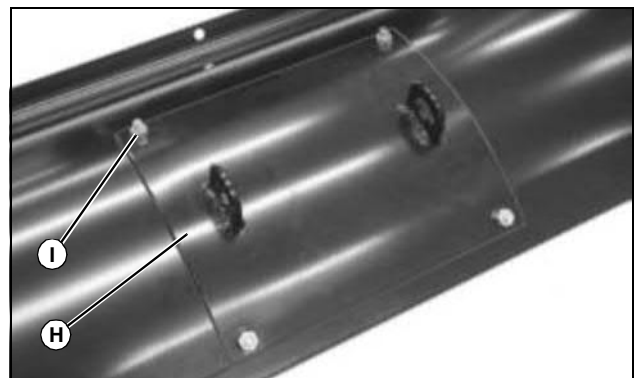

MX10409

3. Attach reinforcement plate (H) to rear of blade using four 5/16X3/4 in. carriage bolts and 5/16 in. lock nuts (I).

Thank you so much for reading.
Please click the “Buy Now!”
button below to download the
complete manual.



After you pay.

You can download the most
perfect and complete manual in
the world immediately.

Our support email:

ebooklibonline@outlook.com