

FEED ROLLS ATTACHMENT FOR NOS. 55 AND 65 COMBINES



OPERATORS MANUAL FEED ROLLS ATTACHMENT FOR NOS. 55 AND 65 COMBINES

OMH34157 A7 English

OMH34157 A7

LITHO IN THE U.S.A.
ENGLISH



TO THE PURCHASER

This Operator's Manual has been carefully written and illustrated to provide you with the necessary information regarding installation, operation and adjustments so that you may obtain maximum service and satisfaction from your Feed Rolls Attachment.

If you should find that you require information not covered in this manual, consult your John Deere dealer. He will be glad to answer any question that may arise regarding the operation of your Feed Rolls Attachment. Your John Deere dealer has trained mechanics who are kept informed on the best John Deere service methods and will render you prompt service if needed.

Location Reference: "Right-hand" and "left-hand" sides are determined by facing in the direction the attachment will travel when in use.

Should your Feed Rolls Attachment require replacement parts, go to your John Deere dealer where you will receive Genuine John Deere Parts—accept no substitutes.

John Deere parts are made to fit properly and insure satisfactory service because they are made from original patterns and from the same materials as used in new machines.

TABLE OF CONTENTS

	Page
OPERATION AND ADJUSTMENTS.....	1
SHIPPING PACKAGES.....	2
INSTALLATION ON Nos. 55 AND 65 COMBINES.....	2-8
BELT PICKUP DRIVE WHEN USED WITH FEED ROLLS ATTACHMENT (No. 55 COMBINES ONLY).....	9

LUBRICATION

Your Feed Rolls Attachment is equipped with **Sealed-For Life Bearings** that require **no** lubrication.

Date of Purchase....., 19....
(To be filled in by Purchaser)

OPERATION AND ADJUSTMENT

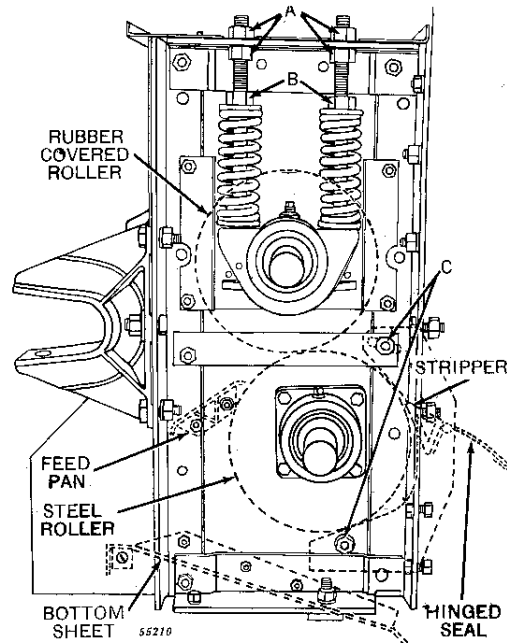

Roll Spacing.

The space between the rolls should be approximately 1/64-inch for flax. Increase roll spacing for use in small grains and beans. To adjust, turn nuts at "A." Check spacing at both ends of rolls by inserting a shim between the rolls. Adjust both sides evenly.

Roll Pressure.

Adjust the roll pressure according to the crop. Crops hard to thresh require greater pressure than crops easy to thresh. Thread nuts "B" onto adjusting bolt to increase spring pressure and off to decrease spring pressure. Adjust both sides evenly.

Stripper Adjustment.

A stripper is provided at the rear of the steel roller to prevent leakage of material. Adjust stripper by loosening bolts at "C," both sides, and move stripper as close to roll as possible without striking. Be sure stripper is parallel to roll, then tighten nuts. *NOTE: Stripper can be inspected by removing clean-out door from bottom of feed rolls housing.*

Cylinder Speed.

Combination cylinder driven and feed roll drive sprockets are available for 793 rpm, 952 rpm, or 1060 rpm cylinder speeds. The purchaser has his choice of one of the three sprockets listed under shipping packages, page 2. The other two sprockets are available as special equipment.

A cylinder speed of 793 rpm is recommended for combining flax.

See chart in Combine Operator's Manual for approximate combine settings for combining various other crops.

INSTALLATION SHIPPING PACKAGES

No. 55 Combines Serial No. 55-12051 and Up	Description	All No. 65 Combines
15500 HH	Feed Rolls Attachment.....	15500 HH
15813 HH	Operator's Platform Support Angles.....	
 Extension Pivot Bracket for Platform Main Axle Support.....	14648 HH
AP 23149 H	Cylinder Driven Sprocket (For 1060 rpm)	AP 23149 H
or		or
15502 HH	Cylinder Driven Sprocket (For 952 rpm)	15502 HH
or		or
15503 HH	Cylinder Driven Sprocket (For 793 rpm)	15503 HH
15061 HH*	Hydraulic Ram Extensions.....	15061 HH*
15062 HH**	Hydraulic Ram Extensions.....	
AP 23010 H†	Parking Brake Connection Angle.....	
15390 HH††	Belt Pickup Drive Jackshaft Sprocket, with Spacer and Hardware.....	

*For No. 55 Combines, Serial No. 55-12051 to 55-29504, and all No. 65 Combines. **IMPORTANT: If No. 55 Combine is equipped with dual sets of hydraulic rams, order two (2) shipping packages No. 15061HH.**

**For No. 55 Combines only, Serial No. 55-29504 and Up.

†For No. 55 Combines only, Prior to Serial No. 55-39350.

††For No. 55 Combines only, when Feed Rolls Attachment and Belt Pickup Attachment are both used on combine.

Check the shipment for shortage, loss or damage. If there is any, make proper notations on the freight bill.

Unpack all shipping packages and arrange the parts conveniently.

The illustrations on the following pages show the proper sequence for installing the Feed Rolls Attachment.

The numbers on the illustrations refer to the numbered paragraphs which explain exactly what should be done.

(Specifications and design subject to change without notice.)

PREPARING THE COMBINE

(Not Illustrated.) Remove feeder conveyor drive chain and detach cutting platform from separator.

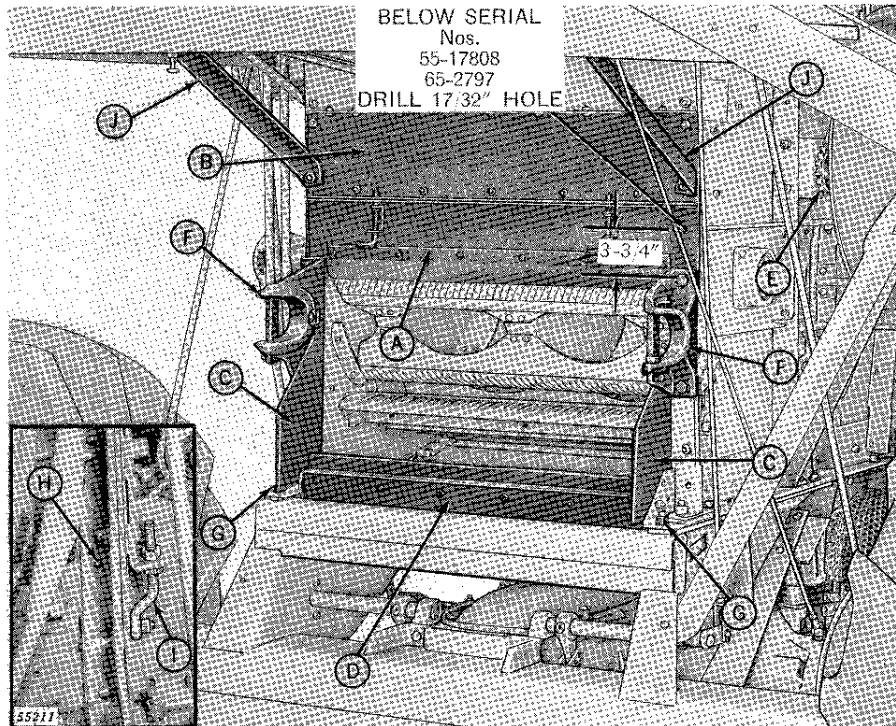

Remove the following parts from your combine:

- A. Front Inspection Door.
- B. Separator Bottom Front Sheet.
- C. Feeder House Seals.
- D. Curved Door and Stops at Front of Conveyor.
- E. Feeder Conveyor Drive Chain Tightener Sprocket.
- *F. Feeder House Pivot Brackets.
- G. Frame Bolts (Front Bolt, Each Side).
- H. Rivet in Separator Front Upright Sill (Both Sides).

No. 55 Combine Only:

- *I. Platform Adjusting Rod (Combines Serial No. 55-42001 and Up Only)
- J. Diagonal Angles for Operator's Platform.
(Not Illustrated.) Parking Brake Rod (Prior to Serial No. 55-39350).

No. 65 Combine Only:

- K. Platform Pivot Bracket.

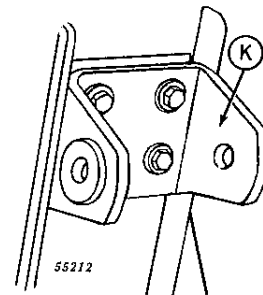

Thank you so much for reading.
Please click the “Buy Now!”
button below to download the
complete manual.



After you pay.

You can download the most
perfect and complete manual in
the world immediately.

Our support email:

ebooklibonline@outlook.com