

# 200 SERIES CUTTING PLATFORMS



JOHN DEERE

## OPERATORS MANUAL 200 SERIES CUTTING PLATFORMS

OMH96974 K6 English

JOHN DEERE HARVESTER WORKS  
OMH96974 K6

LITHO IN THE U.S.A.  
ENGLISH

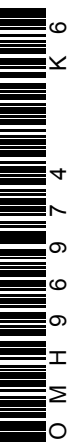



## To the Purchaser

---

This new cutting platform was carefully designed and manufactured to give years of dependable service. To keep it running efficiently, read the instructions in this operator's manual. Each section is clearly identified so you can easily find the information you need—whether it is operation, lubrication, or service. Read the Table of Contents to learn where each section is located. Use the alphabetical index for fast reference.

This manual includes information for 213, 215, 216, 218, 220, 222, and 224 flex and rigid cutting platforms.

 This safety alert symbol identifies important safety messages in this manual. When you see this symbol, be alert to the possibility of personal injury and carefully read the message that follows.

Your operator's manual contains SI Metric equivalents which follow immediately after the U.S. customary units of measure.

In addition to the equipment furnished with your platform, attachments are available to help you do a better job in special crop conditions. These are described in the attachments section of this manual, and can be purchased from your John Deere dealer.

“Right-hand” and “left-hand” sides are determined by facing in the direction the cutting platform will travel when in use.

Record your platform serial number in the space provided on page 61. Your dealer needs this information to give you prompt, efficient service when you order parts or attachments. If your platform requires replacement parts, go to your John Deere dealer where you can obtain Genuine John Deere parts—accept no substitutes.

The warranty on this cutting platform appears on your copy of the purchase order which you should have received from your dealer when you purchased the platform.

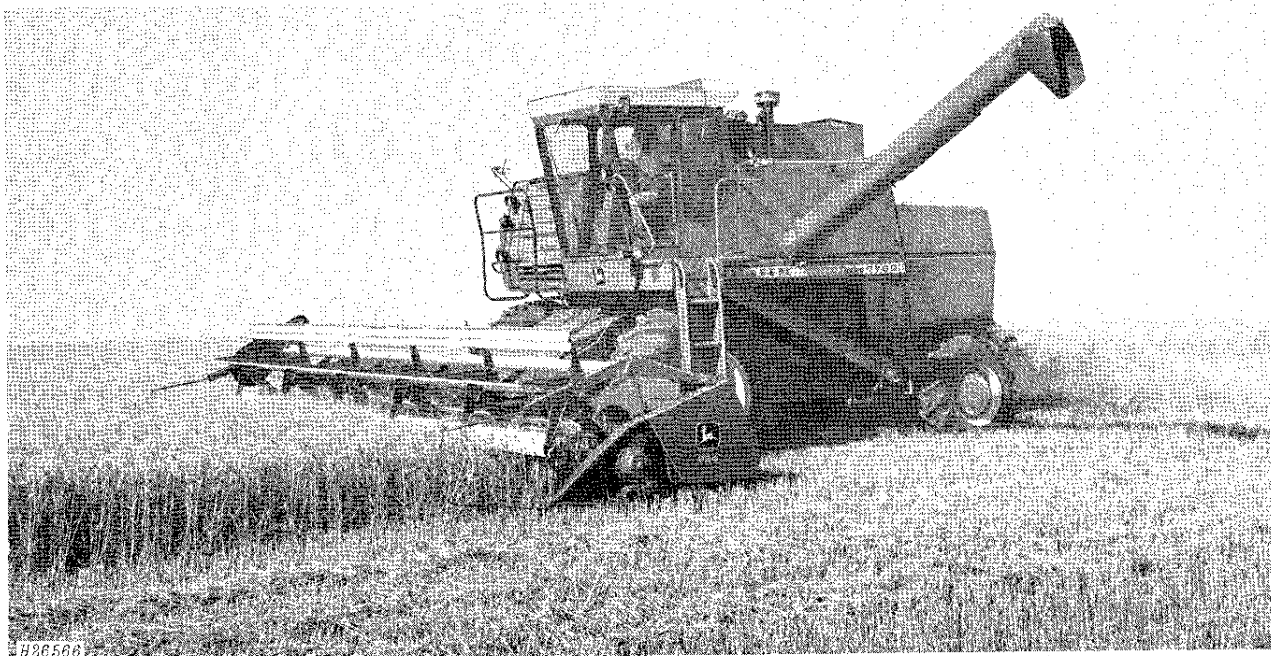



# Contents

	Page
Operation .....	2-31
Lubrication and Periodic Service .....	32-34
Service .....	35-44
Trouble Shooting .....	45-53
Storage .....	54
Installation .....	55-57
Special Equipment .....	58,59
Specifications .....	60,61
Index .....	62

## Safety Suggestions

**⚠** Study these suggestions carefully and insist that they be followed by those working with you and for you.

The safety of the operator was one of the prime considerations in the minds of John Deere engineers when this cutting platform was designed.

All machinery must be operated only by responsible persons who have been delegated to do so.

Only the operator must be allowed on the operator's platform when the combine is in operation.

Never clean, lubricate, or adjust the cutting platform or combine while either is running or in motion. Keep hands and clothing away from all moving parts.

Clothing worn by operator must be fairly tight and belted. Loose jackets, shirts, or sleeves must never be worn because of the danger of getting into moving parts.

Shields and guards must be in place and in good condition before starting in field.

Escaping hydraulic fluid under pressure can have sufficient force to penetrate the skin, causing serious personal injury. Before disconnecting lines, relieve all pressure. Before applying pressure to the system, see that all connections are tight and that lines, pipes and hoses are not damaged. Fluid escaping from a very small hole can be almost invisible. Use a piece of cardboard or wood, rather than hands, to search for suspected leaks.

If injured by escaping hydraulic fluid, see a doctor at once. Serious infection or reaction can develop if

proper medical treatment is not administered immediately.

Never attempt to clear obstructions off the platform unless the combine is stopped and the combine engine is shut off.

When transporting the cutting platform and combine on a road or highway at night or during the day, use lights and devices for adequate warning to operators of other vehicles. In this regard, check local governmental regulations.

Red reflective tape is attached to the rear of the outer shields. When transporting the combine and cutting platform on a road or highway, see that reflective tapes are clean and in place.

Provide a first aid kit for use in case of accident. Use proper antiseptics on scratches and cuts without delay, to prevent the possibility of infection.

When the cutting platform is raised, never crawl under it until you have lowered the combine hydraulic cylinder safety stop. The cylinder safety stop prevents the cutting platform from lowering.

Lower the hydraulic lift reel safety stops when working under the reel.

If spray can paint is used, be careful when discarding empty can. Do not incinerate or puncture can.

Finally, remember this: An accident is usually caused by someone's carelessness, neglect, or oversight.



# Operation

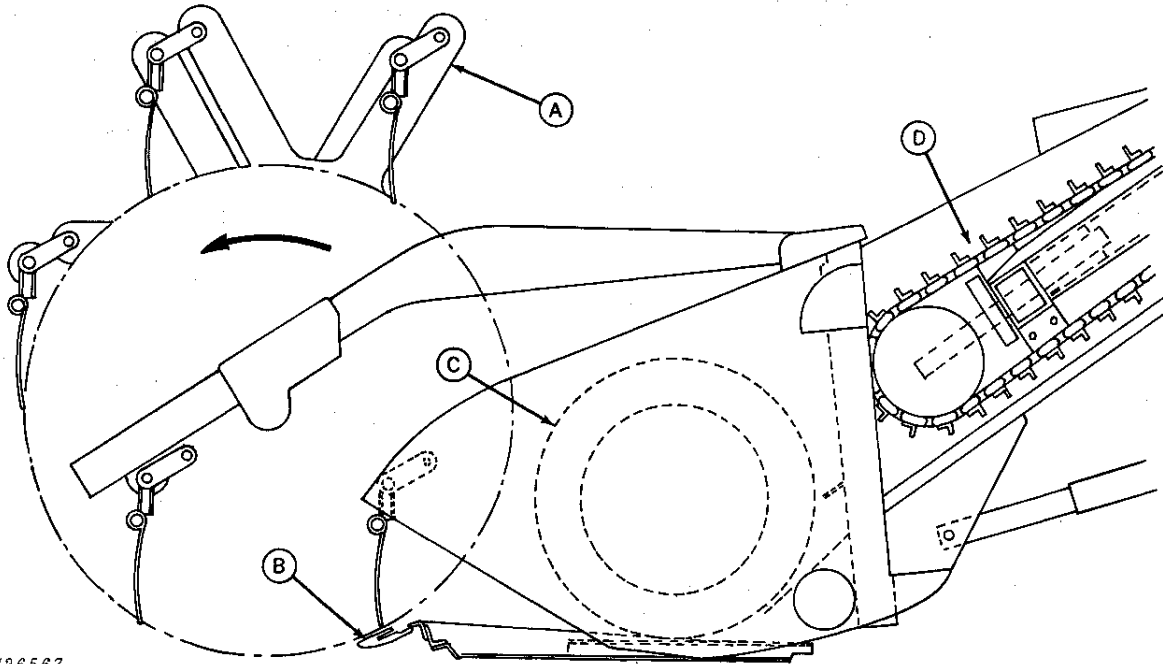

A—Pickup Reel

B—Cutterbar

C—Auger

D—Feeder Conveyor

## GENERAL INFORMATION

The cutting platform receives the crop and moves it to the front of the feeder house by means of the reel, cutterbar, and auger. Retracting fingers in the auger feed the material to the feeder conveyor.

### FLEX CUTTERBAR PLATFORMS

The flex platform cutterbar will flex through a 4-inch (102 mm) range, while skimming over irregular ground on skid shoes. The skid shoes extend the full width of the platform, so there are no adjustments required for various row spacing.

A curved transition plate of spring steel between the cutterbar and the auger, allows the crop to pass smoothly from the cutterbar to the auger. This eliminates "bunching" of the crop and makes the cutterbar an integral part of the platform.

The cutterbar is adjustable through a tilt range of 9 degrees. This range permits the platform bottom to operate parallel with the ground, with any size of combine drive tires.

### RIGID CUTTERBAR PLATFORMS

The distance between the rigid cutterbar and the auger is adjustable to any one of three positions, insuring a smooth flow of material into the feeder house. These three positions are:

1. Rearward or retracted position is recommended when combining crops with green or high moisture straw.
2. 4 inches (102 mm) out or mid-position for most crop conditions.
3. 8 inches (203 mm) out or fully extended. This position works well for short, thin straw, so that the cutterbar can be "swept" by the reel. This position is also useful in tall straw.

Any of these three positions are obtained by sliding the cutterbar in or out and then locking it in place.

The cutterbar is adjustable through a tilt range of 9 degrees. This range permits the platform bottom to operate parallel with the ground, with any size of combine drive tires.

## FIELD OPERATION

### Crop Conditions

Cultural practices and machine adjustment can result in greater differences in crop losses than any other factor. For example, soybean varieties, because of low podding or lodge resistance characteristics, can affect loss levels. Harvesting soybeans at low moisture levels increases shatter losses.

For each crop and ground condition (i.e. standing crop, standing with down heads (maize), down and tangled crops, dry or wet soil, green and weedy crops) the platform and separator must be correctly adjusted.

See the combine operator's manual for separator adjustments. The following are recommended adjustments for the cutting platform:

### Soybeans (Flex Platforms)

#### Normal Dry Conditions

For normal dry conditions adjust flex platform per instructions on page 22.

#### Extremely Dry and Hard Ground Conditions

In extremely dry conditions, the platform may climb up and over stiff soybean stubble, missing low growing beans.

To avoid this, make the following adjustments:

1. Check variable speed feeder house speed. It must operate at 465 rpm. Refer to combine operator's manual for adjustment procedure.

2. Set cutterbar tilt (point of guards pointed down) for minimum tilt. Cutterbar must be locked out for this adjustment. Run a string along the top of cutterbar guards to see that cutterbar is straight. See page 14.

Any adjustment to cutterbar tilt requires readjusting automatic header height control and range indicator.

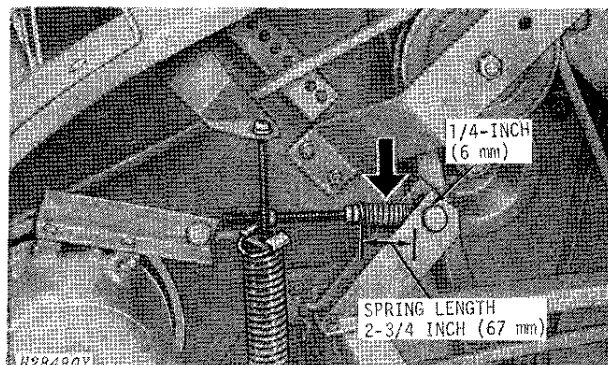

3. Maintain maximum spring pressure and 1/4-inch (6 mm) clearance between the bolt head and the rear of the pivot.

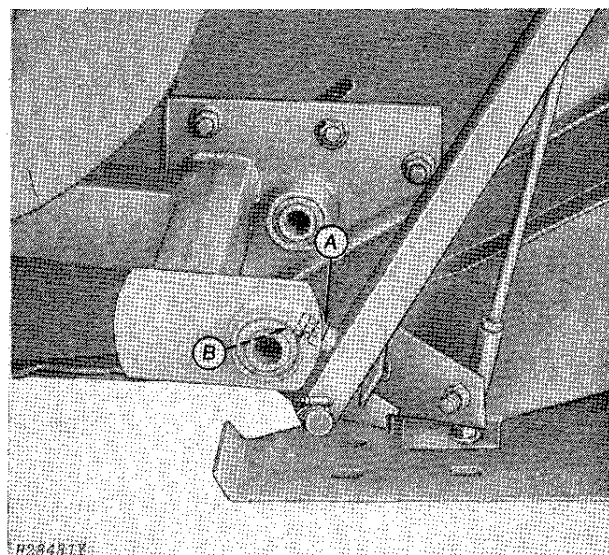

A—Nut

B—Adjusting Screw

4. Adjust range indicator by loosening lock nut "A" and turning adjusting screw "B" until red ball is centered on "0" or zero. Tighten lock nut "A" and remove cutterbar lock-out plates.

## 4 Operation

### Crop Conditions—Continued

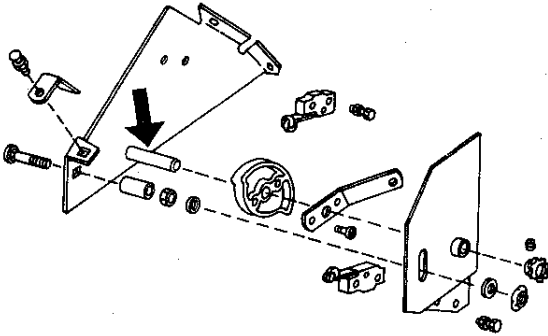

H28482

5. Push up on push rod with turnbuckle and then release. If push rod does not return quickly and hangs up, clean paint off mounting bracket pivot pin for automatic header height control switches. Bracket must be mounted in the rear two holes in the underside of the end sheet edge.

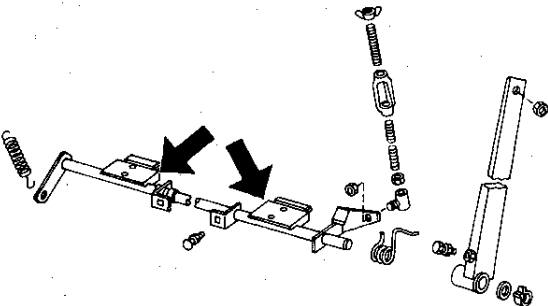

H28483

6. Edges of pads on sensing rod must slide fully on each stop arm. If pads hang up on each stop arm, loosen bolt in the left-hand support bracket and move bracket laterally to center pads on stop arms.

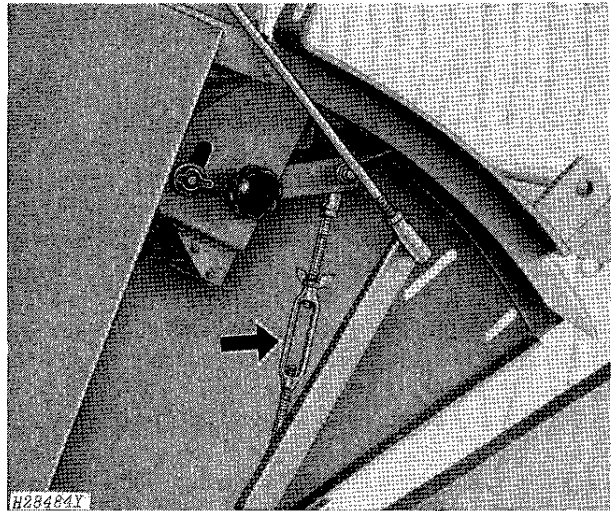

7. Lower platform on a 4 x 4 block placed under the second tilt channel from the left. Lengthen push rod with turnbuckle until the raise switch clicks, then turn the turnbuckle another half turn and tighten wing nut. By alternately lowering the platform on the 4 x 4 block, placed at each tilt channel, check that the raise switch clicks each time. Adjust push rod if necessary.

8. Start combine engine and slightly raise platform until red range indicator ball is on "1-1/2." Loosen wing nut and rotate knob until the lower switch clicks. Tighten wing nut.

**NOTE:** After performing Steps 7 and 8, the raise switch is now set as close to the top of the range as possible. The red ball will indicate between "0" and "1/2" on the range indicator when the raise switch clicks during field operation. The lower switch is now adjusted for an approximate 1-inch (25 mm) dead-band and will click at "1-1/2" on the range indicator when the lower switch clicks during field operation. Dead band is the difference on the range indicator between the raise switch and the lower switch clicking.

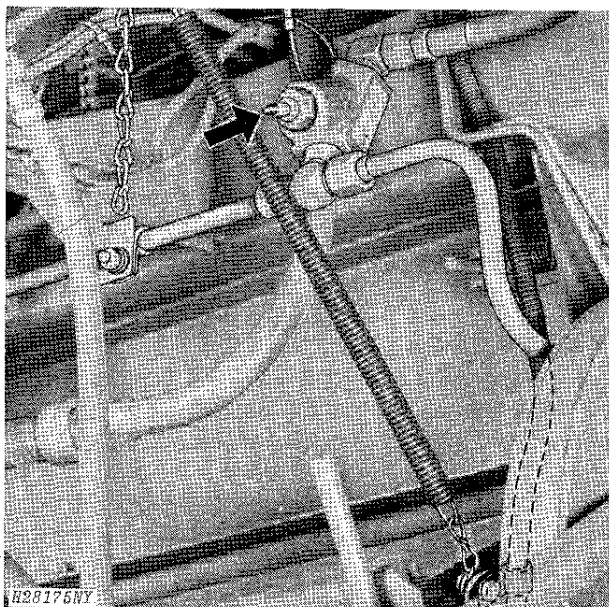

9. Operate platform in the field and observe performance. If header "hunts" or cycles up and down excessively, turn drop rate valve adjusting screw in to slow rate of drop.

#### Wet or Soft Ground Conditions

In wet or soft conditions, the platform may push or plow dirt because the automatic header height control may not be sensing correctly.

The platform will push dirt because of excessive ground pressure.

1. Set cutterbar tilt as recommended on page 14.
2. Release stabilizer spring to free length as recommended on page 17.
3. (Flex Platforms only) Tension cutterbar drive case support spring to pull up on drive case. See page 17.
4. (Flex Platforms only) Adjust range indicator as recommended on page 21.

5. Push up on push rod with turnbuckle and then release. If push rod does not return quickly and hangs up, clean paint off mounting bracket pivot pin for automatic header height control switches. Bracket must be mounted in the rear two holes in the underside of the end sheet edge. See prior page.

6. Edges of pads on sensing rod must slide fully on each stop arm. If pads hang up on each stop arm, loosen bolt in the left-hand support bracket and move bracket laterally to center pads on stop arms. See prior page.

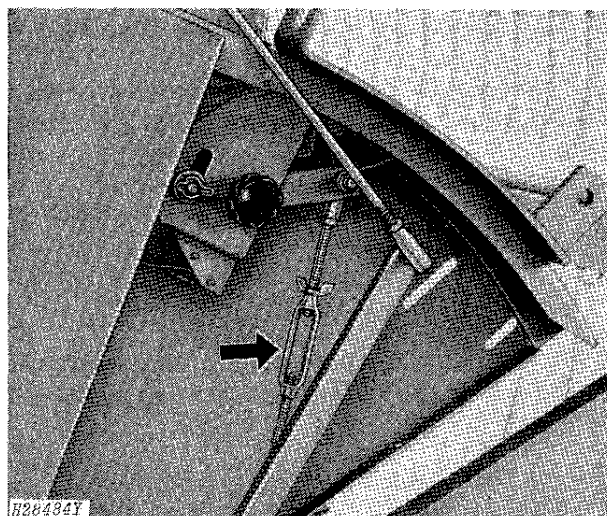

7. Lower platform until red range indicator ball is positioned on "1." Adjust push rod with turnbuckle until raise switch clicks.

8. The automatic header height control should have a 1-1/2 to 2-inch (37 to 51 mm) deadband. (Deadband is the difference on the range indicator between the raise switch and the lower switch clicking). If the deadband is not correct, loosen wing nut and rotate knob clockwise to increase deadband and counter-clockwise to decrease deadband. Tighten wing nut.

9. Operate platform in the field and observe performance. If "plowing" continues, increase length of push rod by two turns of the turnbuckle at a time, until "plowing" of dirt stops. If header "hunts" or cycles up and down excessively, turn drop rate valve adjusting screw in to slow rate of drop.

## 6 Operation

### Combining Standing Grain Crops - Oats, Maize, and Wheat (Flex and Rigid Platforms)

#### Normal Dry Ground Conditions

1. When combining standing crops, such as wheat, soybeans, or maize, the cutterbar should be adjusted to the mid or fully extended position. The fully extended position is also recommended when using a bat reel, as in short light crops, to "sweep" the cutterbar. See pages 15 and 16.

2. For maize, sunflowers, etc., it may be necessary to raise the platform cross auger. See page 18.

3. Set reel so the slats, in their lowest position, strike just below the lowest grain heads and slightly ahead of the knife. See page 8.

4. Pickup reel fingers must be set perpendicular to the cutterbar. See page 9.

5. Lock out the flex cutterbar. See page 17.

6. The floating divider points on a flex platform may be too long for use in standing grain crops and can be removed. See page 19.

#### Short, Damp, Green, or Weedy Crops

In short, damp, green, or weedy crops, plugging or slug feeding may occur. Large quantities of weeds tend to gum up the sieves and impart moisture to the grain.

Weeds should be disposed of quickly and not be broken up any more than necessary.

The following suggestions will help while operating in weedy conditions.

- A. Cut the grain as high as possible.
- B. Try to avoid weeds and undergrowth.
- C. Check to see that cylinder is operating at proper speed.
- D. Use as much blast on shoe as possible without blowing over grain.
- E. Lower rear end of adjustable chaffer.

1. Lock out flexible cutterbar except for soybeans. Move rigid cutterbar to rearward position for green material or forward for very short straw. On both platforms, tilt cutterbar up as far as possible. See pages 14 and 17.

2. If combining soybeans with flexible cutterbar, adjust automatic header height control to top of range to keep cutterbar as high as possible and platform bottom as flat as possible.

3. Move reel back and down. Do not use the front two holes in the support arms with floating divider points. Adjust pitch of pickup reel fingers so they are perpendicular to the cutterbar. See page 9.

4. Adjust auger down and back for rigid platforms and down and forward for flexible platforms. See page 18.

5. Remove paint, rust, dirt, or crop residue from the platform bottom under the auger.

6. Remove optional feeder house closure strips. Do not use strips unless wrapping of feeder conveyor drive shaft occurs. See combine operator's manual.

7. To prevent tailings from being thrown down the feeder house and restricting the flow of material in the auger finger area, adjust cylinder front door stripper as close to the cylinder as possible. See combine operator's manual.

8. Adjust feeder conveyor drum "float" to the grain position. See combine operator's manual.

*NOTE: Incorrect drum height (drum "float" adjusted to the corn position) causes most feeding problems.*

9. Adjust feeder conveyor chain for the correct distance above false bottom. See operator's manual.

10. Adjust feeder conveyor chain speed for grain crops, by installing drive chain on the LARGER 23-tooth sprocket. See combine operator's manual.

11. If feeding problems persist, install auger flight extensions. See page 59.



Thank you so much for reading.  
Please click the “Buy Now!”  
button below to download the  
complete manual.



After you pay.

You can download the most  
perfect and complete manual in  
the world immediately.

Our support email:

[ebooklibonline@outlook.com](mailto:ebooklibonline@outlook.com)