

**JOHN DEERE**  
**WORLDWIDE COMMERCIAL & CONSUMER**  
**EQUIPMENT DIVISION**

---

**Compact Utility Tractor**  
**2210**

OMLVU14661 G3

**OPERATOR'S MANUAL**

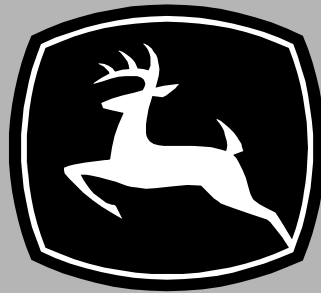

**JOHN DEERE**

**⚠ WARNING:** Diesel engine exhaust and some of its constituents are known to the State of California to cause cancer, birth defects, and other reproductive harm.

California Proposition 65 Warning

North American Version  
Litho in U.S.A.

# INTRODUCTION

---

## Thank You for Purchasing a John Deere Product

We appreciate having you as a customer and wish you many years of safe and satisfied use of your machine.

## Using Your Operator's Manual

This manual is an important part of your machine and should remain with the machine when you sell it.

Reading your operator's manual will help you and others avoid personal injury or damage to the machine.

Information given in this manual will provide the operator with the safest and most effective use of the machine.

Knowing how to operate this machine safely and correctly will allow you to train others who may operate this machine.

If you have an implement, use the safety and operating information in the implement operator's manual along with the machine operator's manual to operate the implement safely and correctly.

This manual and safety signs on your machine may also be available in other languages (see your John Deere dealer to order).

Sections in your operator's manual are placed in a specific order to help you understand all the safety messages and learn the controls so you can operate this machine safely. You can also use this manual to answer any specific operating or servicing questions. A convenient index located at the end of this book will help you to find needed information quickly.

The machine shown in this manual may differ slightly from your machine, but will be similar enough to help you understand our instructions.

RIGHT-HAND and LEFT-HAND sides are determined by facing in the direction the machine will travel when going forward. When you see a broken line arrow (----->), the item referred to is hidden from view.

Before delivering this machine, your dealer performed a predelivery inspection to ensure best performance.

## Special Messages

Your manual contains special messages to bring attention to potential safety concerns, machine damage as well as helpful operating and servicing information. Please read all the information carefully to avoid injury and machine damage.



**CAUTION: Avoid injury! This symbol and text highlight potential hazards or death to the operator or bystanders that may occur if the hazards or procedures are ignored.**

**IMPORTANT: Avoid damage! This text is used to tell the operator of actions or conditions that might result in damage to the machine.**

***NOTE: General information is given throughout the manual that may help the operator in the operation or service of the machine.***

# PRODUCT IDENTIFICATION

## Record Identification Numbers

### Compact Utility Tractor with Hydrostatic Transmission

2210 PIN (110001- )

If you need to contact an Authorized Service Center for information on servicing, always provide the product model and serial number.

You will need to locate the model and serial number for the machine and for the engine of your machine and record the information in the spaces provided below.

DATE OF PURCHASE:

\_\_\_\_\_

DEALER NAME:

\_\_\_\_\_

DEALER PHONE:

\_\_\_\_\_

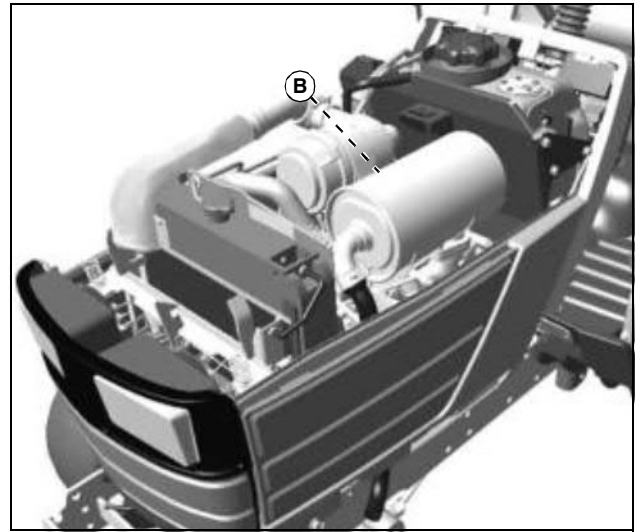

MX17260

ENGINE SERIAL NUMBER (B):

-----



MX17229

PRODUCT IDENTIFICATION NUMBER (A):

-----

# TABLE OF CONTENTS

---

Safety .....	1
Operating.....	11
Replacement Parts .....	30
Service Intervals.....	31
Service Lubrication.....	32
Service Engine .....	34
Service Transmission.....	44
Service Electrical.....	48
Service Miscellaneous.....	54
Troubleshooting .....	58
Storage .....	63
Assembly .....	64
Specifications .....	66
Warranty .....	70
Index.....	73

All information, illustrations and specifications in this manual are based on the latest information at the time of publication. The right is reserved to make changes at any time without notice.

COPYRIGHT© 2003  
Deere & Co.  
John Deere Worldwide Commercial and  
Consumer Equipment Division  
All rights reserved  
Previous Editions  
COPYRIGHT© 2002

OMLVU14661 G3 - English

# SAFETY

## Understanding The Machine Safety Labels

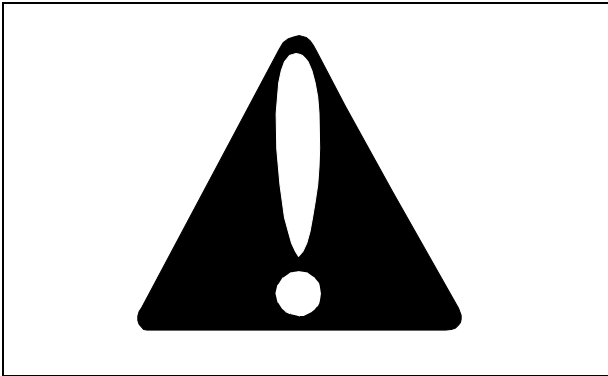

Safety-Alert Symbol

The machine safety labels shown in this section are placed in important areas on your machine to draw attention to potential safety hazards.

On your machine safety labels, the words DANGER, WARNING, and CAUTION are used with this safety-alert symbol. DANGER identifies the most serious hazards.

The operator's manual also explains any potential safety hazards whenever necessary in special safety messages that are identified with the word, CAUTION, and the safety-alert symbol.

## WARNING: AVOID CRUSHING

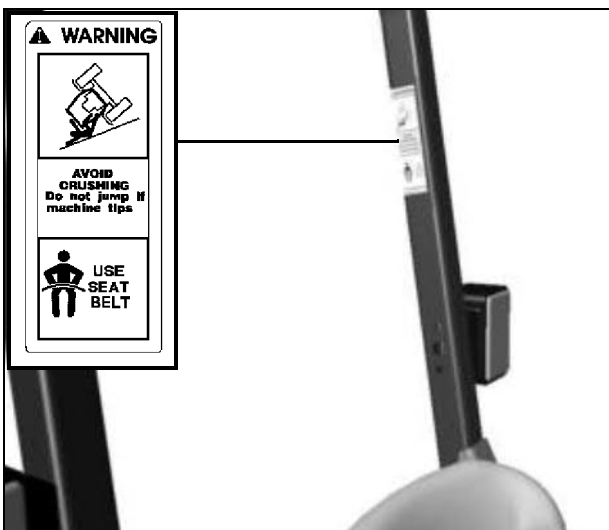

MX17520, M76637

Do not jump if machine tips

USE SEAT BELT

## CAUTION

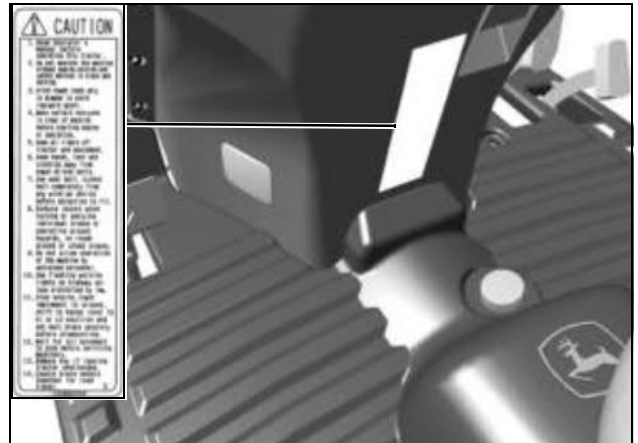

MX17558, LVU800725

1. Read Operator's Manual before operating this tractor.
2. Do not operate the machine without guards, shields, and safety devices in place and working.
3. Hitch towed loads only to drawbar to avoid rearward upset.
4. Make certain everyone is clear of machine before starting engine or operation.
5. Keep all riders off tractor and equipment.
6. Keep hands, feet and clothing away from power-driven parts.
7. Use seat belt. Extend belt completely from any wind-up device before adjusting to fit.
8. Reduce speed when turning or applying individual brakes or operating around hazards, on rough ground or steep slopes.
9. Do not allow operation of the machine by untrained personnel.
10. Use flashing warning lights on highway unless prohibited by law.
11. Stop engine, lower implement to ground, shift Range lever to HI or LO position and set park brake securely before dismounting.
12. Wait for all movement to stop before servicing machinery.
13. Remove key if leaving tractor unattended.
14. Couple brake pedals together for road travel.

Thank you so much for reading.  
Please click the “Buy Now!”  
button below to download the  
complete manual.



After you pay.

You can download the most  
perfect and complete manual in  
the world immediately.

Our support email:

[ebooklibonline@outlook.com](mailto:ebooklibonline@outlook.com)