

# **Special Edition LX178 Motorsport**

## **OPERATOR'S MANUAL**

**John Deere  
Worldwide Commercial and  
Consumer Equipment Division  
OMM129094 J6**

North American Version  
Litho in U.S.A  
English

# INTRODUCTION

---

---

**THANK YOU** for purchasing a John Deere product.

Read this manual and your attachment manuals thoroughly. Failure to do so could result in personal injury or equipment damage.



**WARNING:** The Engine Exhaust from this product contains chemicals known to the State of California to cause cancer, birth defects or other reproductive harm.

CALIFORNIA Proposition 65 Warning

This manual should be considered a permanent part of your machine and should remain with the machine when you sell it.

Measurements in this manual are metric units and their U.S. customary equivalents. RIGHT-HAND and LEFT-HAND sides are determined by facing in the direction the machine will travel when going forward. When you see a broken line arrow ( - - - → ) it indicates the part it is pointing to is hidden.

Record identification numbers below. Be sure to record all the numbers to help in tracing the machine if it is stolen. You also need to give these numbers to your dealer when you order parts.

**Date of Purchase:**  
\_\_\_\_\_

**Dealer Name:** \_\_\_\_\_ **Phone:** \_\_\_\_\_

**Vehicle Serial Number:**

□ □ □ □ □ □ □ □ □ □ □ □ □ □ □ □

**Engine Serial Number:**

□ □ □ □ □ □ □ □ □ □ □ □ □ □ □ □

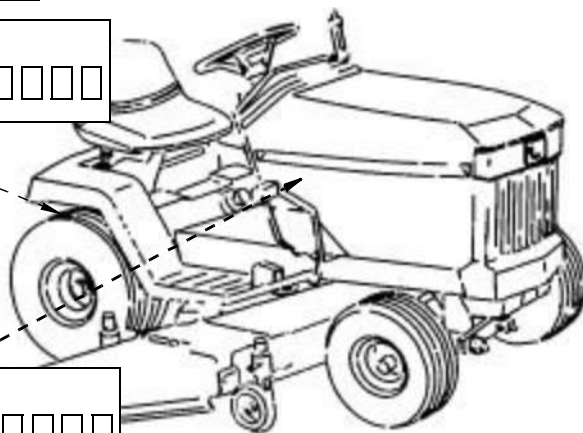

## INTRODUCTION

---

---

Few sports in the world today have the power, the enthusiasm and the loyalty as NASCAR.

And few sponsors on the NASCAR circuit have as good a fit as John Deere and motorsports.

The reason is simple. Customers like you.

First of all, thank you for purchasing this special edition John Deere Motorsports Lawn Tractor. And congratulations on making a buying decision that will reward you for many seasons to come of enjoyable machine operation.

It's a safe bet when the slogan Nothing Runs Like a Deere® was first used some 25 years ago, 190 miles per hour was not what they had in mind. But that is exactly what is happening as a green-and-yellow Pontiac Grand Prix, competes in the Winston Cup Series in 1997.

Moving "up to Cup", makes a powerful statement for John Deere... their customers...and motorsports fans. You know what it takes to be a success on the extraordinarily competitive Winston Cup circuit.

It takes incredible teamwork to build and keep the vehicle running. High precision and high performance components. Significant investments in research and development. Testing in some of the most brutal conditions in the world today. A world-class dedication to safety. A continuous effort toward product improvement to get the competitive edge. And finally, a driver who constantly desires to be the best his team helps him to be.

Sounds a lot like how John Deere people engineer, build and support the lawn tractor you now own.

Sponsoring a John Deere NASCAR vehicle has often been talked about over the years...but the timing wasn't right. Many of our customers have a long-time interest in auto racing. Many have hands on experience. Stockcar "roots" run deep with a significant portion of John Deere customers and employees.

---

## INTRODUCTION

---

---

Today NASCAR's Winston Cup Series, is on a global growth curve that is out of this world. The Series encompasses over 30 races that will run from California to Texas to New Hampshire and Florida...and many racetracks in-between.

This uniquely American series of events is gaining momentum overseas as well. Great tracks exist in Japan and Australia...with more on the horizon.

While the courses vary, the scene on race day is much the same. Huge crowds, often over 100,000 strong, are at the track, while millions more tune in on the television and radio. It's a frenzy of thundering engines, cheering fans, and blurring, decaled cars pushing 200 miles per hour.

John Deere's driver, Chad Little, will be behind the wheel of the "97" car. His roots in auto racing run deep as well.

"My dad raced cars", explains Little, "and when I was 15, I raced hobby stocks at tracks around my hometown of Spokane, Washington."

Racing remained an important part of Little's life, racing summers as he got a college business degree and then a law degree. After law school, Little took on racing full-time.

Supporting the efforts at the track is a wide array of motorsports merchandise for the race fan to purchase. Stop into your John Deere dealer to find out more information about race date schedules and merchandise.

Thanks again...and look for the John Deere green and yellow "97" on televised races from February through November. Or if your schedule allows...buy a ticket to a race and experience the power of motorsports for yourself.

---

## TABLE OF CONTENTS

---

	Page
<b>Safety Signs</b> .....	1
<b>Controls</b> .....	4
<b>Operating the Machine</b> .....	7
<b>Operating the Mower</b> .....	24
<b>Lawn Care</b> .....	37
<b>Replacement Parts</b> .....	44
<b>Service Machine Safely</b> .....	46
<b>Service Intervals</b> .....	49
<b>Service-Engine</b> .....	50
<b>Service-Transmission</b> .....	64
<b>Service-Steering and Brakes</b> .....	66
<b>Service-Mower</b> .....	68
<b>Service-Electrical</b> .....	82
<b>Service-Miscellaneous</b> .....	90
<b>Removing and Storing Mower</b> .....	95
<b>Installing Mower</b> .....	100
<b>Troubleshooting</b> .....	103

Thank you so much for reading.  
Please click the “Buy Now!”  
button below to download the  
complete manual.



After you pay.

You can download the most  
perfect and complete manual in  
the world immediately.

Our support email:

[ebooklibonline@outlook.com](mailto:ebooklibonline@outlook.com)