

HD45 and HD75 Commercial Walk-Behind Mowers

Serial No.(010001 -)



OPERATOR'S MANUAL

John Deere
Worldwide Commercial And
Consumer Products Divison
OMM131726 F7

North American Version
Litho in U.S.A.
English

INTRODUCTION

THANK YOU for purchasing a John Deere product.

Read this manual and your attachment manuals thoroughly. Failure to do so could result in personal injury or equipment damage.

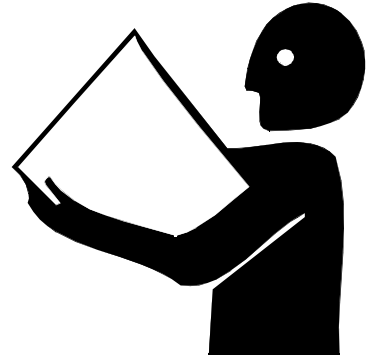

WARNING: The Engine Exhaust from this product contains chemicals known to the State of California to cause cancer, birth defects or other reproductive harm.

CALIFORNIA Proposition 65 Warning

This manual should be considered a permanent part of your machine and should remain with the machine when you sell it.

Measurements in this manual are metric units and their U.S. customary equivalents. RIGHT-HAND and LEFT-HAND sides are determined by facing in the direction the machine will travel when going forward. When you see a broken line arrow, it indicates the part it is pointing to is hidden.



Record identification numbers below. Be sure to record all the numbers to help in tracing the machine if it is stolen. You also need to give these numbers to your dealer when you order parts.

DATE OF PURCHASE: _____

DEALER NAME: _____

DEALER PHONE: _____

Engine Serial Number:

<input type="text"/>	<input type="text"/>	<input type="text"/>	<input type="text"/>	<input type="text"/>	<input type="text"/>	<input type="text"/>	<input type="text"/>	<input type="text"/>	<input type="text"/>	<input type="text"/>	<input type="text"/>	<input type="text"/>	<input type="text"/>	<input type="text"/>	<input type="text"/>	<input type="text"/>	<input type="text"/>	<input type="text"/>	<input type="text"/>
----------------------	----------------------	----------------------	----------------------	----------------------	----------------------	----------------------	----------------------	----------------------	----------------------	----------------------	----------------------	----------------------	----------------------	----------------------	----------------------	----------------------	----------------------	----------------------	----------------------

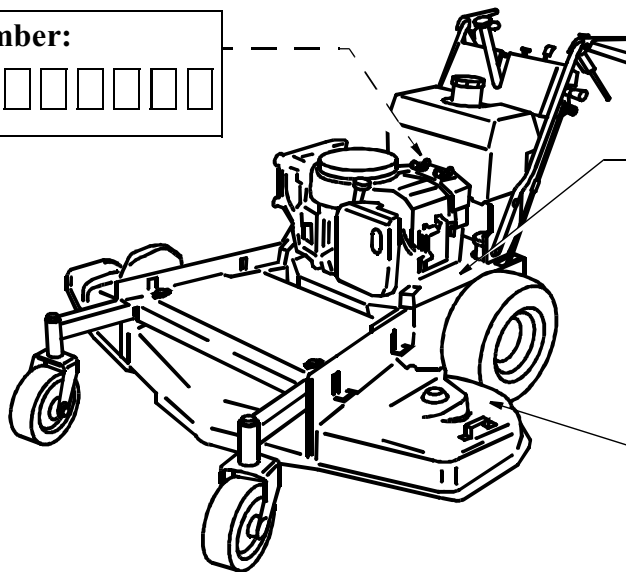

Power Unit Identification Number:

<input type="text"/>	<input type="text"/>	<input type="text"/>	<input type="text"/>	<input type="text"/>	<input type="text"/>	<input type="text"/>	<input type="text"/>	<input type="text"/>	<input type="text"/>	<input type="text"/>	<input type="text"/>	<input type="text"/>	<input type="text"/>	<input type="text"/>	<input type="text"/>	<input type="text"/>	<input type="text"/>	<input type="text"/>	<input type="text"/>
----------------------	----------------------	----------------------	----------------------	----------------------	----------------------	----------------------	----------------------	----------------------	----------------------	----------------------	----------------------	----------------------	----------------------	----------------------	----------------------	----------------------	----------------------	----------------------	----------------------

Mower Deck Serial Number:

<input type="text"/>	<input type="text"/>	<input type="text"/>	<input type="text"/>	<input type="text"/>	<input type="text"/>	<input type="text"/>	<input type="text"/>	<input type="text"/>	<input type="text"/>	<input type="text"/>	<input type="text"/>	<input type="text"/>	<input type="text"/>	<input type="text"/>	<input type="text"/>	<input type="text"/>	<input type="text"/>	<input type="text"/>	<input type="text"/>
----------------------	----------------------	----------------------	----------------------	----------------------	----------------------	----------------------	----------------------	----------------------	----------------------	----------------------	----------------------	----------------------	----------------------	----------------------	----------------------	----------------------	----------------------	----------------------	----------------------

TABLE OF CONTENTS

Safety	1
Controls	4
Operating	7
Replacement Parts	28
Service Machine Safely	29
Service Interval Chart	31
Service - Engine	33
Service - Transmission	40
Service - Steering and Brakes	49
Service - Mower	51
Service - Electrical	66
Service - Miscellaneous	72
Troubleshooting	77
Storing Machine	80
Assembly	82
Specifications	93
Warranty	101
Index	105
John Deere Service Literature	113

All information, illustrations and specifications in this manual are based on the latest information at the time of publication. The right is reserved to make changes at any time without notice.

COPYRIGHT© 1997
John Deere Horicon Works
All rights reserved

SAFETY SIGNS

Safety-Alert Symbol

Read and recognize safety information. Be alert to the potential for personal injury when you see this safety-alert symbol.

On your machine safety labels, the words DANGER, WARNING, and CAUTION are used with this safety-alert symbol. DANGER identifies the most serious hazards. In this manual, the word CAUTION and this symbol call attention to safety messages.

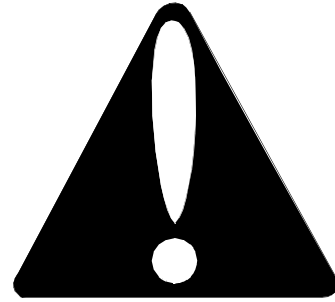

Machine Safety Labels

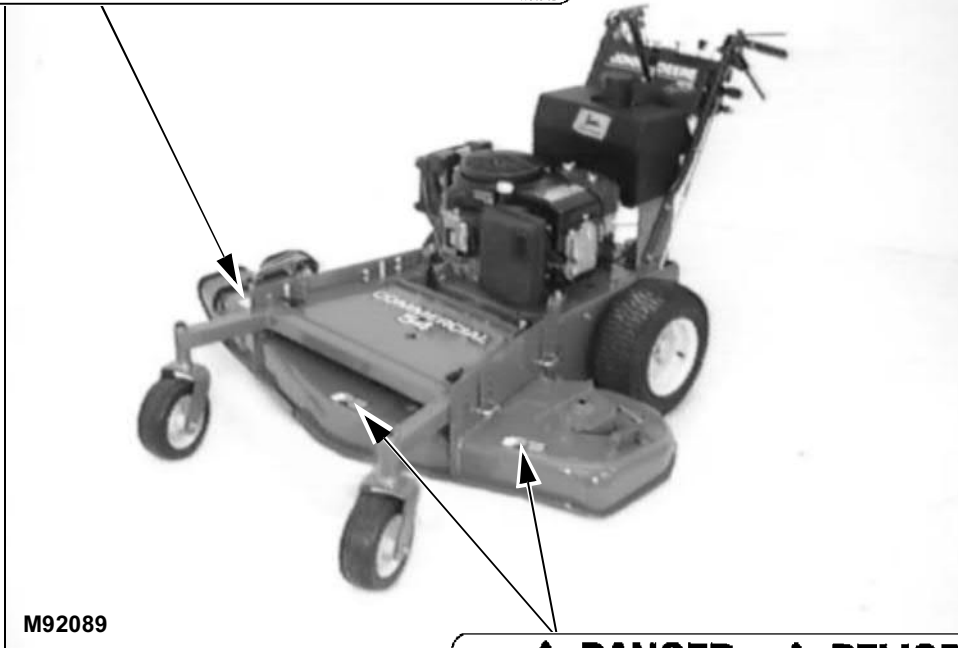

M92089

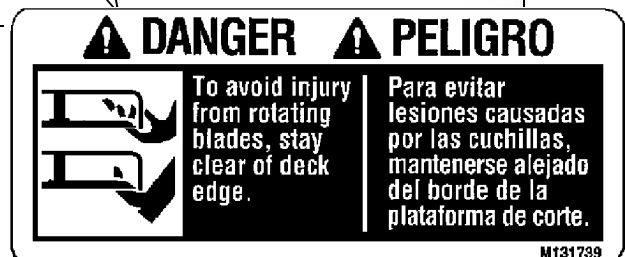

SAFETY SIGNS

⚠ CAUTION

To avoid injury, read operator's manual.
Before servicing or leaving:
Stop engine, lock brake levers and remove key.

⚠ ATENCION

Para evitar lesiones, leer el Manual del operador. Antes de realizar servicio a la máquina o abandonarla: Apagar el motor, trabar las palancas de freno y sacar la llave.

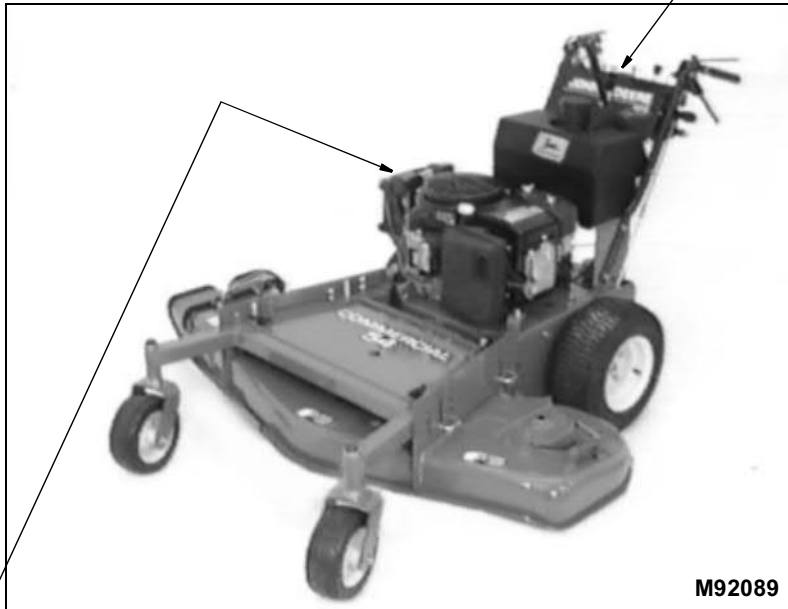

⚠ DANGER

EXPLOSIVE GASES Cigarettes, flames or sparks could cause battery to explode. Always shield eyes and face from battery. Do not charge or use booster cables or adjust post connections without proper instruction and training. Keep vent caps tight and level.

POISON

CAUSES SEVERE BURNS Contains sulfuric acid. Avoid contact with the skin, eyes or clothing. In event of accident, flush with water and call a physician immediately. Keep out of reach of children.

⚠ PELIGRO

GASES EXPLOSIVOS Los cigarrillos, llamas o chispas podrían causar una explosión. Siempre protegerse los ojos y la cara. Nunca cargar la batería, usar cables puente o ajustar las conexiones de los bornes sin tener el conocimiento. Mantener las tapas apretadas y niveladas.

VENENO

CAUSA GRAVES QUEMADURAS Contiene ácido sulfúrico evitar el contacto con la piel, ojos o ropa. En caso de accidente, enjuagar con agua y llamar a un médico inmediatamente. Mantener lejos del alcance de los niños.

Thank you so much for reading.
Please click the “Buy Now!”
button below to download the
complete manual.



After you pay.

You can download the most
perfect and complete manual in
the world immediately.

Our support email:

ebooklibonline@outlook.com