

500 SERIES ROD WEEDER



JOHN DEERE

OPERATORS MANUAL 500 SERIES ROD WEEDER

OMN59859 (01AUG59) English

OMN59859 (01AUG59)

LITHO IN THE U.S.A.
ENGLISH



TO THE PURCHASER

The purpose of this manual is to furnish valuable information about your new John Deere 500 Series Rod Weeder. In this manual, you will find instructions and helpful suggestions for operating, hitching, adjusting, lubricating, and assembling your new weeder.

Keep this manual in a convenient place for quick and easy reference. Use it as a guide whenever questions arise. You have purchased a dependable, sturdy machine, but only by proper care and operation can you expect to receive the service and long life designed and built into it.

If you need additional information, or if your weeder requires special servicing, see your John Deere dealer. He will be glad to serve you.

Sometime in the future, your weeder may need new parts to replace worn or broken parts, or emergency service may be required that is not covered in this manual. If so, we suggest that you take advantage of the facilities offered by your John Deere dealer, which assure you of genuine John Deere parts and prompt "know-how" service in the field or shop.

When ordering parts, provide your dealer with the model number of your Rod Weeder, its type, and year purchased. This information will help him to identify the part you need. We suggest that this information be recorded immediately in the space provided below, thereby making it available for future reference.

By giving your weeder proper attention during slack periods, it will always be ready for use, without delays, when you need it.

John Deere No.....	Rod Weeder
Date Purchased.....	19....

TABLE OF CONTENTS

	<i>Page</i>
IDENTIFICATION VIEWS	2-3
SPECIFICATIONS	4
OPERATION AND ADJUSTMENT	5-13
General	5
Lift Levers	6
Powr-Trol for 512A, 514A, and 514B Rod Weeders	7
Adjusting Upper Drive Chain	8
Adjusting Lower Drive Chain	8
Adjusting Hitch for Penetration	8
Hitching	9-11
Transporting	12-13
SAFETY SUGGESTIONS	14
LUBRICATION	15
ASSEMBLY INSTRUCTIONS	16-41
General	16
Shipping Bundles	17-18
ASSEMBLY—510A ROD WEEDERS	19-25
Drive Wheels	19
Drive Chain Sprocket Housing	20
Gauge Wheels and Frame	21
Lift Shaft	22
Lift Shaft and Lever	22
Center Boot	23
Pendants and Shoes	24
Rotary Rod	25
ASSEMBLY—512A, 514A, AND 514B ROD WEEDERS	26-36
Drive Wheels	26
Drive Chain Sprocket Housing	27
Gauge Wheel Frame	28
Gauge Wheels	29
Lift Shaft and Quadrant	29
Lift Lever	30
Hydraulic Remote Cylinder Adapter	30-33
Center Boot	34
Pendants and Shoes	35
Rotary Rod	36
ASSEMBLY—EXTRA EQUIPMENT	37-41
Multiple Unit Hitch	37-39
Single Unit Hitch	40
Endwise Transport Hitch	41
Endwise Transport Hitch—Second Unit	41
Endwise Transport Wheel	42

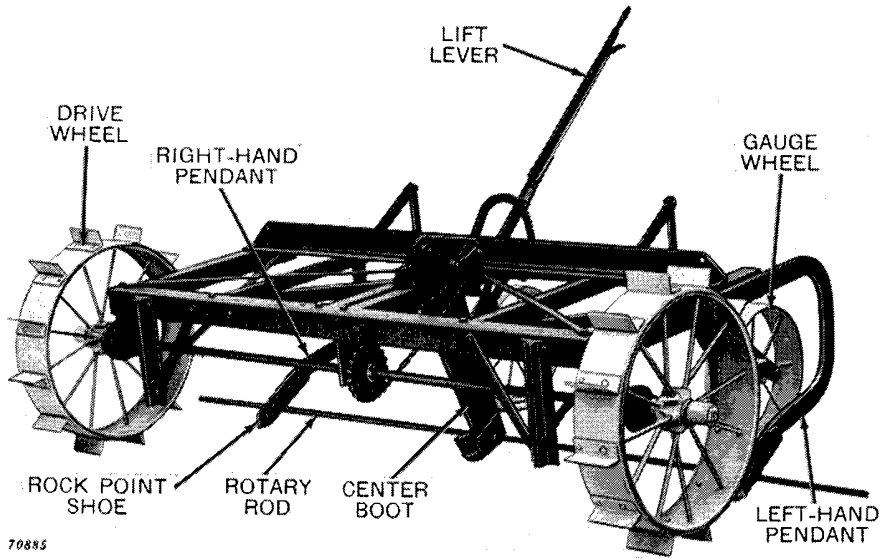

John Deere 510A Rod Weeder, 10-Foot with Steel Wheels

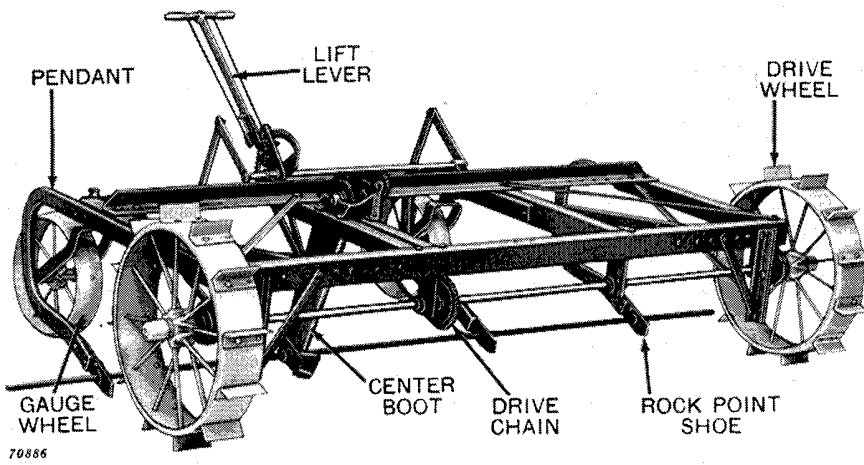

John Deere 512A Rod Weeder, 12-Foot with Steel Wheels

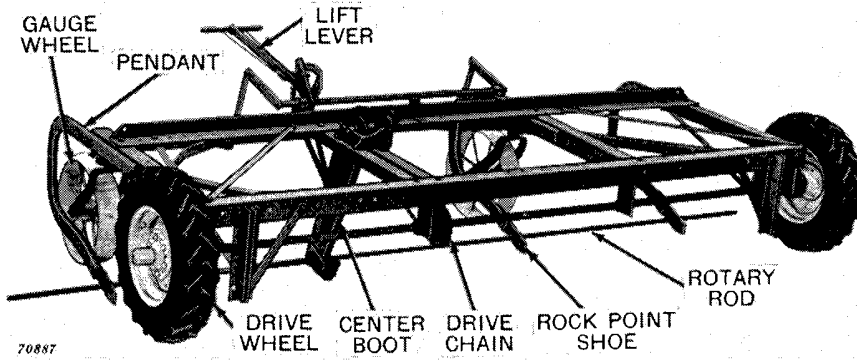

John Deere 514A Rod Weeder, 14-Foot, with Rubber-Tired Drive Wheels and Concave Steel Gauge Wheels

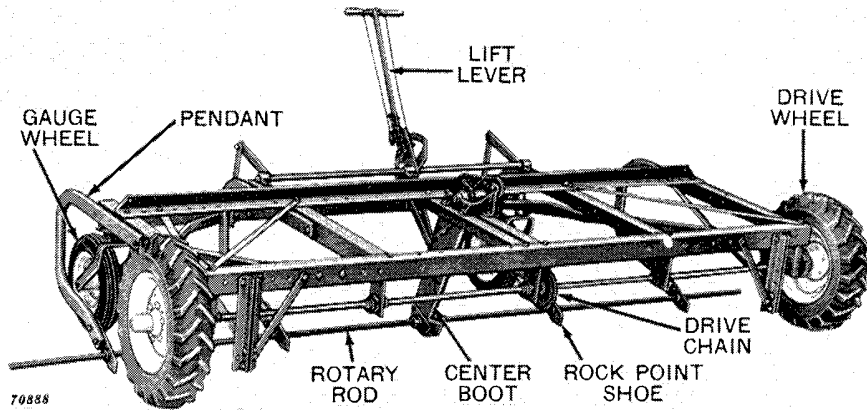

John Deere 514B Rod Weeder, 14-Foot, with Rubber-Tired Wheels

SPECIFICATIONS

SERIES.....	500 Drawn Rod Weeder consists of four models, all of which are equipped with heavy-duty pendants and steel wheels.
MODELS.....	510A Rod Weeder, 10-foot, 3 pendants 512A Rod Weeder, 12-foot, 4 pendants 514A Rod Weeder, 14-foot, 4 pendants 514B Rod Weeder, 14-foot, 5 pendants
ROTARY ROD	
LENGTH.....	510A Rod is 10 feet 6 inches 512A Rod is 12 feet 6 inches 514A Rod is 14 feet 6 inches 514B Rod is 14 feet 6 inches
OPERATING SPEED...	3 to 5 miles per hour
OPTIONAL EQUIP- MENT.....	Pendant Pointed Shoes may be ordered in lieu of regular Rock Point Shoes. Rubber-Tired Drive Wheels, with tires, or Rubber-Tired Drive Wheels, less tires, may be ordered in lieu of steel wheels. Rubber-Tired Gauge Wheels with Tires, or Concave Steel Gauge Wheels, may be ordered in lieu of Convex Steel Gauge Wheels.
EXTRA EQUIPMENT..	Powr-Trol for 512A, 514A, and 514B Rod Weeders 16-Foot Rotary Rod for 514B Rod Weeders. High Speed Drive Sprockets for all models. Hitches Single Unit Hitch for any model Wide Single Unit Hitch for 514A and 514B Rod Weeders 2-510 Cable Hitch for two 510A Rod Weeders 3-510 Cable Hitch for three 510A Rod Weeders 2-512 Cable Hitch for two 512A Rod Weeders 3-512 Cable Hitch for three 512A Rod Weeders 2-514 Cable Hitch for two 514A or 514B Rod Weeders 3-514 Cable Hitch for three 514A or 514B Rod Weeders Endwise Transport Hitch for one or more units Rubber-Tired Transport Wheels

(Specifications and design subject to change without notice.)

OPERATION AND ADJUSTMENT

GENERAL

The John Deere 500 Series Rod Weeder is a drawn unit of simple, sturdy construction, incorporating many outstanding features to assure long life and rugged dependability.

The center drive is comprised of an enclosed chain within a narrow boot which is slanted to the rear. Two large drive wheels are connected to the drive axle by ratchets to provide continuous rotation of the rotary rod. The drive axle itself is mounted on roller bearings as are the gauge wheels. A 1-1/4-inch pitch implement roller chain is used throughout the drive to insure positive non-clogging operation.

Extreme rearward center of gravity is provided for most efficient penetration of the 7/8-inch square rod. A single lever in the center of the 510A Rod Weeder raises the rod for transport and lowers it to operating position. Because of greater weight to be lifted on the 12- and 14-foot machines, a unique ratchet type lever is used to raise and lower the machine for depth gauging. If your rod weeder is equipped with Powr-Trol, a mere touch of the tractor hydraulic control lever will raise and lower the machine to the desired depth.

Heavy-duty, 1 x 3-inch pendants are used on all models. Heavy-duty pendants are especially designed for use in rocky soil. The rock-point shoes, illustrated below, are regular equipment and should be used in rocky soil conditions where the pendants may strike hidden rocks. However, in rock-free soil, it may be desirable to use the pointed shoes, also illustrated below.

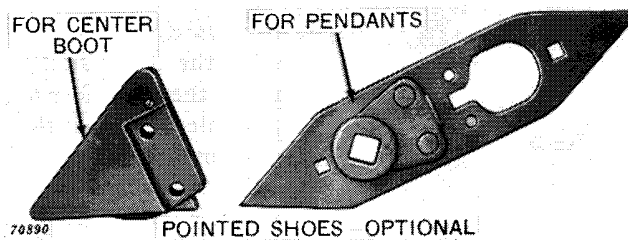
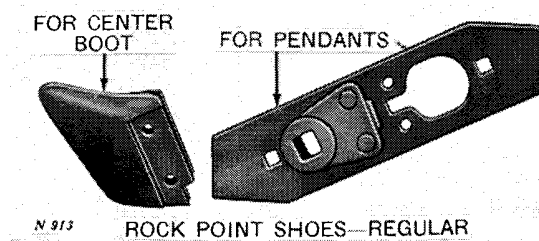

LIFT LEVER FOR 510A ROD WEEDERS

The lever, shown at right, is provided to raise the rotary rod out of the ground when transporting, and to return the rod to the proper position when operating. The lever is shown set in the forward position for the greatest penetration of the rod. Pull this lever toward the rear to decrease the operating depth, and all the way rearward to raise the rod for transport.

LIFT LEVER FOR 512A, 514A, AND 514B ROD WEEDERS

This lever, shown below, is equipped with two pawls which engage the quadrant so that a jacking action is provided for raising or lowering the weeder. While holding the position of the weeder with one pawl, the other pawl can be moved to another notch in the quadrant without the operator having to hold the weight of the machine as it is raised or lowered. This allows the operator to raise or lower the machine slowly and it provides a double lock to hold the weeder in the desired position.

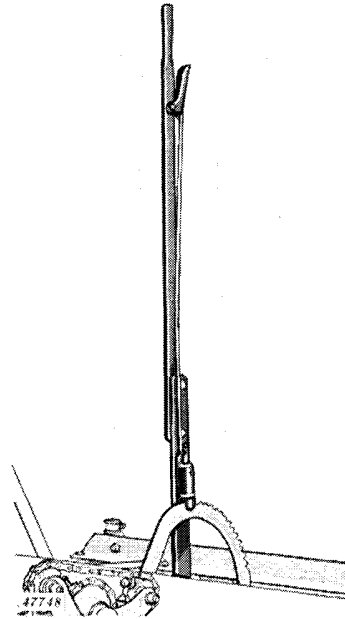

To Raise—Push the left handle down and move the lever forward as far as possible. Then rock the right handle down, and move the lever backward as far as possible. Repeat this cycle of movements until the desired position is reached, then lock both pawls in the quadrant by leveling both handles.

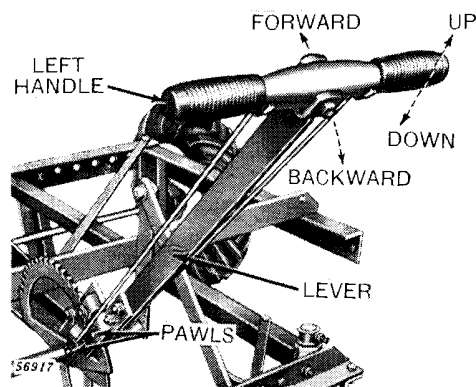

To double lock the weeder in the raised position, set the lever up against the mounting plate as shown at left. A stop prevents the lever from moving too far to the rear and binding.

To Lower—Push the right handle down and move the lever backward as far as possible. Then rock the left handle down and move the lever forward as far as possible. Repeat this cycle of movements until the desired position is reached, then lock both pawls in the quadrant by leveling both handles.

POWR-TROL FOR 512A, 514A, AND 514B ROD WEEDERS

The depth of operation of a Powr-Trol rod weeder is accurately controlled by the operator from the tractor seat by means of the tractor's hydraulic system. For operation of the Powr-Trol system, see your tractor Operator's Manual. To place the rod weeder in operating position, install

cylinder with two attaching pins, extend cylinder so pin can be removed from the storage or transport hole and place the pin in hole "A."

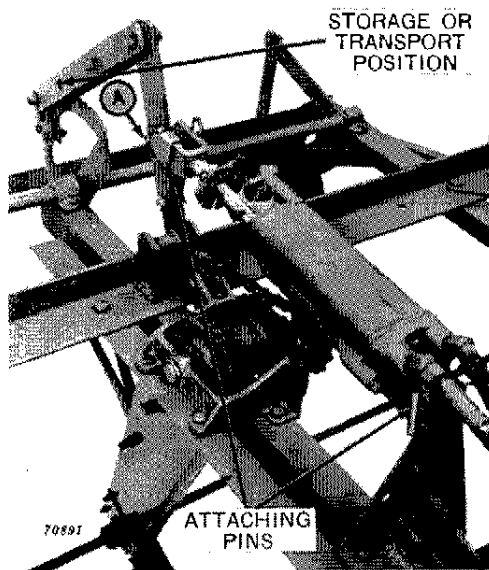

To remove hydraulic cylinder from the rod weeder, raise the weeder to the lift position, remove pin from hole "A" and place it in storage or transport position. Relieve the load on the cylinder and remove attaching pins. The rod weeder will then be held in the lifted position and can be stored or transported without replacing the cylinder.

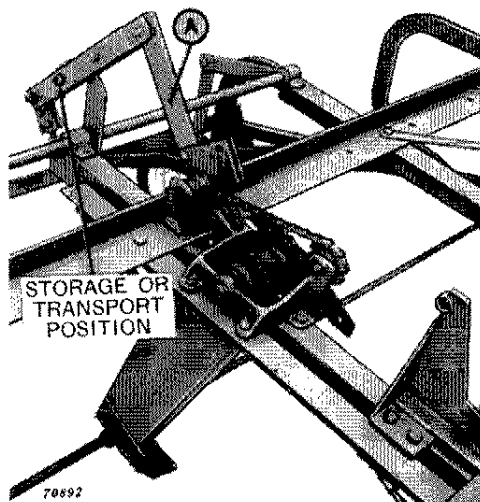

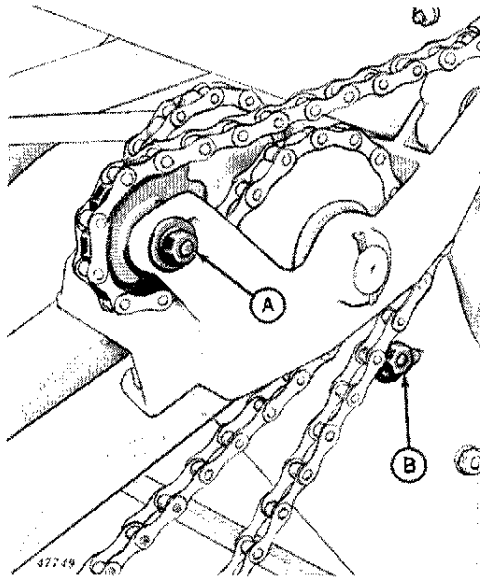

ADJUSTING UPPER DRIVE CHAIN

The tension of the upper drive chain can be adjusted by use of the chain tightener sprocket, "A," shown at left. To adjust, loosen the bolt, place the sprocket in the desired position, and retighten the bolt. Moving the sprocket toward the rear will loosen it. Operate with the chain tight, but avoid any extreme tightness that would cause excessive wear on the chain.

ADJUSTING LOWER DRIVE CHAIN

The lower drive chain can be tightened or loosened by adjustment of the chain tightener sprocket, "B," shown at left.

This will enable you to take up a small amount of slack without removing links from the chain. To adjust, loosen the bolt, slide the sprocket to the desired position, and retighten the bolt. Moving the sprocket upward in the slot will increase tension, and downward will decrease tension. Operate with the chain tight, but avoid any tightness that would cause excessive wear on chain.

ADJUSTING HITCH FOR PENETRATION

For maximum rod penetration, the hitch must be set in the lowest possible position, "A," shown at right. To decrease the amount of penetration, raise the hitch point to one of the higher holes. If it becomes necessary to attach the hitch to the second hole, "B," remove the hitch support brace, "C," by removing bolts at "B" and at "D." This will leave the hole at "B" open for the hitch attaching point. Reinstall the hitch support brace with bolts at "A" and "D." Note that it is necessary to use rear hole in brace at "D," when attaching front end of brace to lower point "A." Be sure to set both sides similarly.

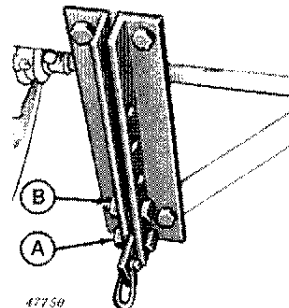
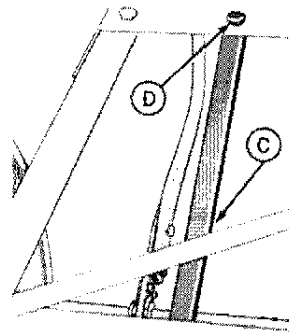

Thank you so much for reading.
Please click the “Buy Now!”
button below to download the
complete manual.



After you pay.

You can download the most
perfect and complete manual in
the world immediately.

Our support email:

ebooklibonline@outlook.com