

JOHN DEERE
WORLDWIDE COMMERCIAL & CONSUMER
EQUIPMENT DIVISION

**SelectSpray Attachment for ProGator
HD200 and HD300**

HD200 (050001-), HD300 (025001-)

OMTCU26461 D9

OPERATOR'S MANUAL



JOHN DEERE

Original Instruction

All information, illustrations and specifications in this manual are based on the latest information at the time of publication. The right is reserved to make changes at any time without notice.

COPYRIGHT© 2009

Deere & Co.

**John Deere Worldwide Commercial and
Consumer Equipment Division**

All rights reserved

Previous Editions

COPYRIGHT© 2009

North American Version

Litho in U.S.A.

INTRODUCTION

Introduction

Using Your Operator's Manual

Read this entire operator's manual, especially the safety information, before operating.

This manual is an important part of your machine. Keep all manuals in a convenient location so they can be accessed easily.

Use the safety and operating information in the attachment operator's manual, along with the machine operator's manual, to operate and service the attachment safely and correctly.

If your attachment manual has a section called Preparing the Machine, it means that you will have to do something to your tractor or vehicle before you can install the attachment. The Assembly and Installation sections of this manual provide information to assemble and install the attachment to your tractor or vehicle. Use the Service section to make any needed adjustments and routine service to your attachment.

If you have any questions or concerns with the assembly, installation, or operation of this attachment, see your local John Deere dealer or call the John Deere Customer Contact Center at 1-800-537-8233 for assistance.

Warranty information on this John Deere attachment can be found in the warranty that came with your John Deere tractor or vehicle.

Product Identification

Product Compatibility

The HD200 and HD300 Sprayer Attachments are compatible with ProGator™ utility vehicles.

Record Identification Numbers

HD200 Serial Number - (050001-)

HD300 Serial Number - (025001-)

If you need to contact an Authorized Service Center for information on servicing, always provide the product model and serial number.

You will need to locate the model and serial number for the attachment and record the information in the spaces provided below.

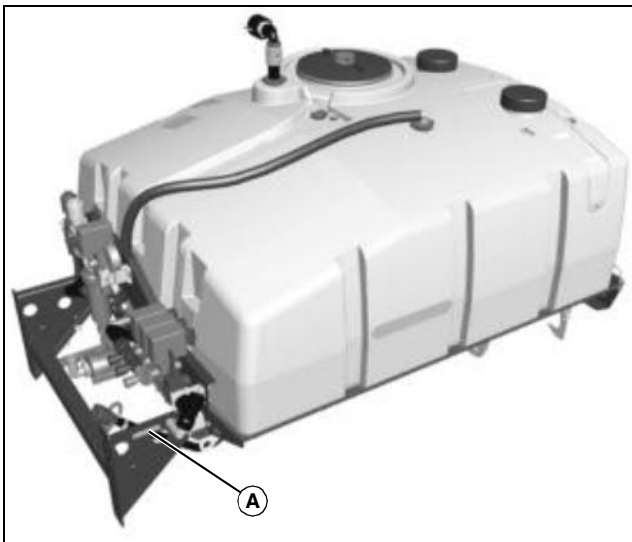

MX42625

DATE OF PURCHASE:

DEALER NAME:

DEALER PHONE:

PRODUCT SERIAL NUMBER (A):

Safety Labels



Understanding The Machine Safety Labels

The machine safety labels shown in this section are placed in important areas on your machine to draw attention to potential safety hazards.

On your machine safety labels, the words DANGER, WARNING, and CAUTION are used with this safety-alert symbol. DANGER identifies the most serious hazards.

The operator's manual also explains any potential safety hazards whenever necessary in special safety messages that are identified with the word, CAUTION, and the safety-alert symbol.

SAFETY LABELS

Safety Labels

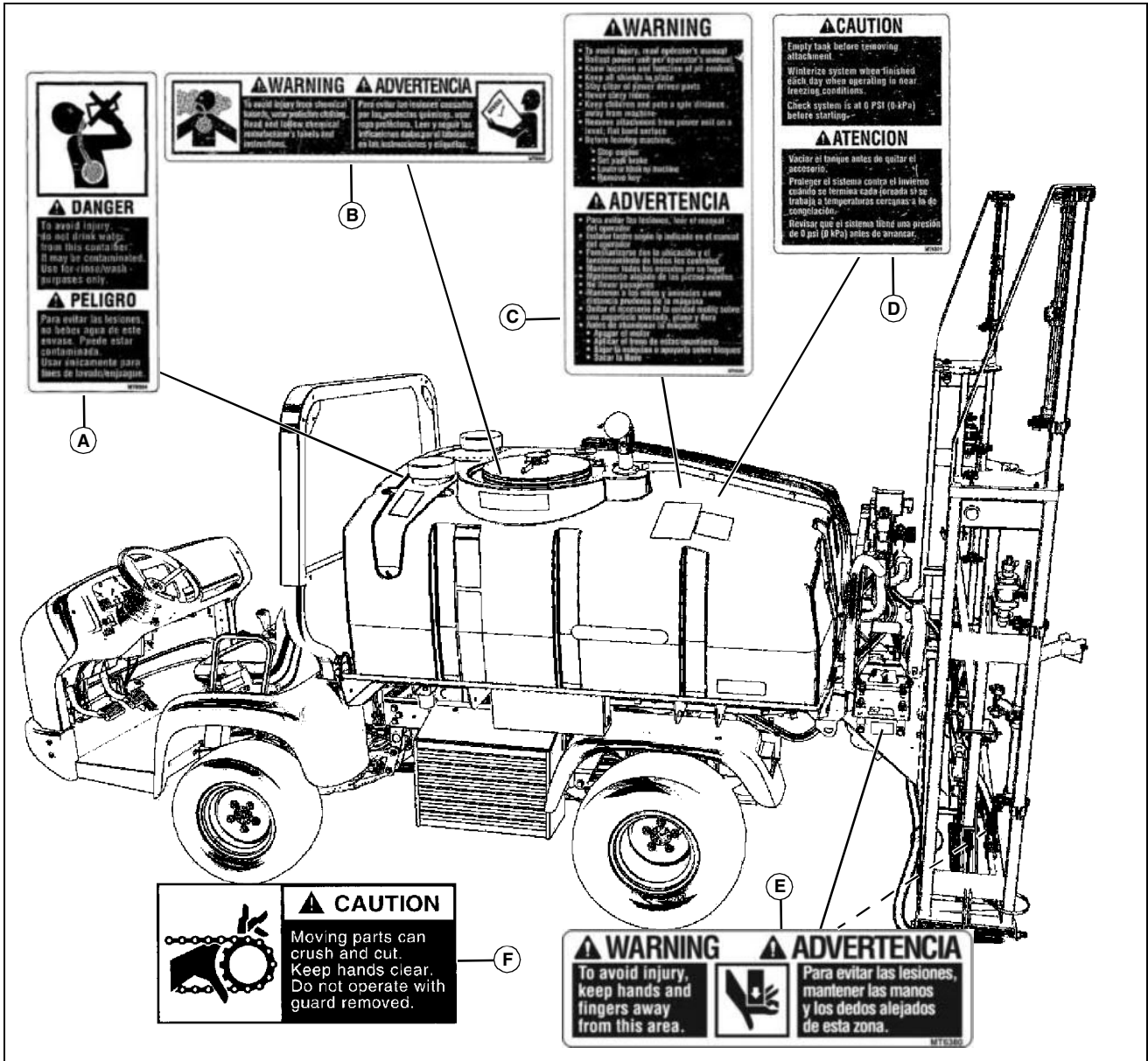

MX42169

Picture Note: Use label number listed in table below to locate complete text of safety label message following this illustration. HD200 model shown.

- A- DANGER MT6304
- B- WARNING MT6302
- C- WARNING MT6300
- D- CAUTION MT6301
- E- WARNING MT6380
- F- CAUTION MX3605 (On optional hose reel kit)

SAFETY LABELS

WARNING MT6300



MT6300

- To avoid injury, read operator's manual.
- Ballast power unit per operator's manual.
- Know location and function of all controls.
- Keep all shields in place.
- Stay clear of power driving parts.
- Never carry riders.
- Keep children and pets a safe distance away from machine.
- Remove attachment from power unit on a level, flat, hard surface.
- Before leaving machine:
 - Stop engine.
 - Set park brake.
 - Lower or block up machine.
 - Remove key.

CAUTION MT6301



MT6301

Empty tank before removing attachment.

Winterize system when finished each day when operating in near freezing conditions.

Check system is at 0 PSI (0 kPa) before starting.

WARNING MT6302



MT6302

To avoid injury from chemical hazards, wear protective clothing. Read and follow chemical manufacturer's labels and instructions.

DANGER MT6304



MT6304

To avoid injury, do not drink water from this container. It may be contaminated. Use for rinse/wash purposes only.

Warning



MT6380

- To avoid injury, keep hands and fingers away from this area.

SAFETY

WARNING MT4163



MT4163

Picture Note: For optional electric actuator kit.

To avoid injury, keep hands and fingers away from this area.

CAUTION MX3605

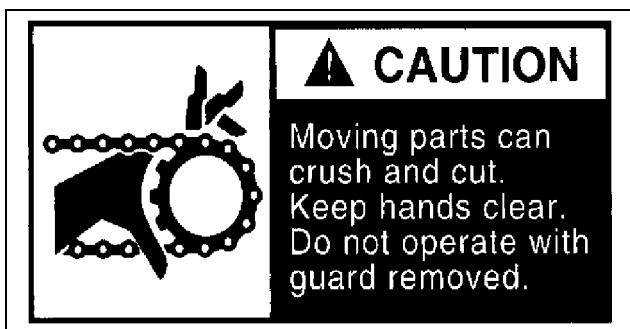

MX3605

Picture Note: For optional electric hose reel kit.

Moving parts can crush and cut. Keep hands clear. Do not operate with guards removed.

Safety

Read Safety in Machine Operator's Manual

Read the general safety operating precautions in your machine operator's manual for additional safety information.

Operate Safely

- Read the machine and attachment operator's manual carefully. Be thoroughly familiar with the controls and the proper use of the equipment. Know how to stop the machine and disengage the controls quickly.
- Do not let children or an untrained person operate machine.
- Make any necessary adjustments before you operate. Never attempt to make any adjustments while the engine is running, unless if recommended in adjustment procedure.
- Take all possible precautions when leaving the machine unattended. Shut off the engine before making any repairs, adjustments, or inspections. Lower the attachment, lock the parking brake, stop the engine, and remove the key.
- Look behind machine before you back up. Back up carefully.
- Do not let anyone, especially children, ride on machine or attachment. Riders are subject to injury such as being struck by foreign objects and being thrown off. Riders may also obstruct the operator's view, resulting in the machine being operated in an unsafe manner.
- Use only attachments and accessories approved by the manufacturer of

this product.

- If the machine vibrates abnormally, stop the engine and check immediately for the cause. Vibration is generally a warning of trouble.
- Always refer to the Storage section of the operator's manual for important details if storing this product for a long period of time.
- Keep people and pets out of the work area. Stop machine if anyone enters the area.
- If you hit an object, stop the machine and inspect it. Make repairs before you operate. Keep machine properly maintained and in good working order. Keep all shields and guards in place.
- Always inspect the sprayer completely before and after each use. Before pressurizing the system, check to be sure all fittings and hoses are tightly installed. Be sure guards and shields are in good condition and fastened in place. Make any necessary adjustments before you operate.
- Never use the sprayer during windy conditions.
- Always release pressure in the system before filling, cleaning or servicing the sprayer.
- Do not put nozzle tip or other sprayer parts to your lips to blow out dirt. Use compressed air.
- If the sprayer is mounted to the bed of a utility vehicle, never raise the bed with the sprayer tank filled completely. Drain tank to below lowest fill line before raising for service or other reason.

Parking Safely

1. Stop vehicle on a level surface, not on a slope.
2. Lock park brake.
3. Stop engine.
4. Remove key.
5. Before you leave the operator's seat, wait for engine and all moving parts to stop.
6. Disconnect the negative battery cable or remove the spark plug wire (for gasoline engines) before servicing the machine.

Mix and Handle Chemicals Safely

- It is best to wear full cover clothing and always wear protective goggles and rubber gloves to protect yourself while handling chemicals.
- Follow instructions on chemical container labels.
- Open all chemical containers carefully, using proper tools.
- Open, pour, weigh and mix chemicals in a well-ventilated area.
- Reserve all equipment used for the application of chemicals exclusively for that purpose.
- Prohibit all smoking, drinking and eating food in chemical-handling area.
- It is a good practice to take a soapy shower immediately after the using the sprayer to apply chemicals.
- Wash all clothing worn when using chemicals separately in the laundry after spraying is completed.

Read Chemical Container Label

- Chemicals can be dangerous. Improper selection or use can injure persons, animals, plants, soils or other property. Select the right chemical for the job and handle and apply with care.
- Read the instructions, precautions, and warnings on the container label before opening. Use the product strictly according to label directions for specific applications, in the amounts specified, at the times specified and

Thank you so much for reading.
Please click the “Buy Now!”
button below to download the
complete manual.



After you pay.

You can download the most
perfect and complete manual in
the world immediately.

Our support email:

ebooklibonline@outlook.com