

# 245 Heavy-Duty Rear Blade



## OPERATORS MANUAL 245 Heavy-Duty Rear Blade

OMU14268 Issue G1 English

**OMU14268 Issue G1**

LITHO IN U.S.A.  
ENGLISH



## To the purchaser



Read this operator's manual carefully, and follow the instructions on operation, safety, and service. When in need of parts, see your John Deere dealer. He can provide high-quality genuine John Deere parts to maintain the life and satisfactory performance of your blade.

When term "right" or "left" is used, it means from a position behind the machine, facing the direction of travel.

Study this manual carefully. Keep it handy for reference.

This manual covers the operation, service, assembly instructions, and parts list for the John Deere 245 Heavy-Duty Rear Blade.

Fill in the data below for future information.

The 245 Blade is built for all-around versatility. It has tilt, angle, offset, reverse and changing pitch features required for a variety of work conditions.

Machine model.....

Date purchased.....19.....

## Contents

	Page
SPECIFICATIONS .....	1
OPERATIONS .....	3-7
Preparing Tractor .....	3
Attaching to Tractor .....	4
Operating Blade Controls .....	4
Operating Tractor .....	4
Angling and Reversing the Blade .....	5
Removing the Gauge Wheel .....	5
Pitching the Blade .....	5
Tilting the Blade .....	5
Offsetting the Blade to Right or Left .....	5
Leveling and Grading .....	6
Ditching .....	6
Filling Trenches and Backfilling .....	6
Safety Suggestions .....	7
Extra Equipment .....	7
LUBRICATION AND SERVICE .....	8
Lubrication .....	8
Bolt Torque .....	8
Reversing or Replacing Cutting Edge .....	8
ASSEMBLY .....	9
PARTS LIST AND ILLUSTRATIONS .....	10-13

## Specifications

Weight (Without Gauge Wheel) .....	570 lbs.
Moldboard Length .....	72 in.
Moldboard Height .....	18 in.
Moldboard Thickness .....	5/16 in.
Cutting Edge .....	1/2 x 6 x 72 in. (Reversible and Replaceable High-Carbon Steel)
Blade Positions . . .	Straight Forward or Reversed
	Angled Right or Left, 15°, 30°, 45°
	Centered, or Offset to Right or Left 12 in.
	Tilted Right or Left 15°, 30°
	Pitched Front-to-Rear 5°

*(Specifications and design are subject to change without notice)*

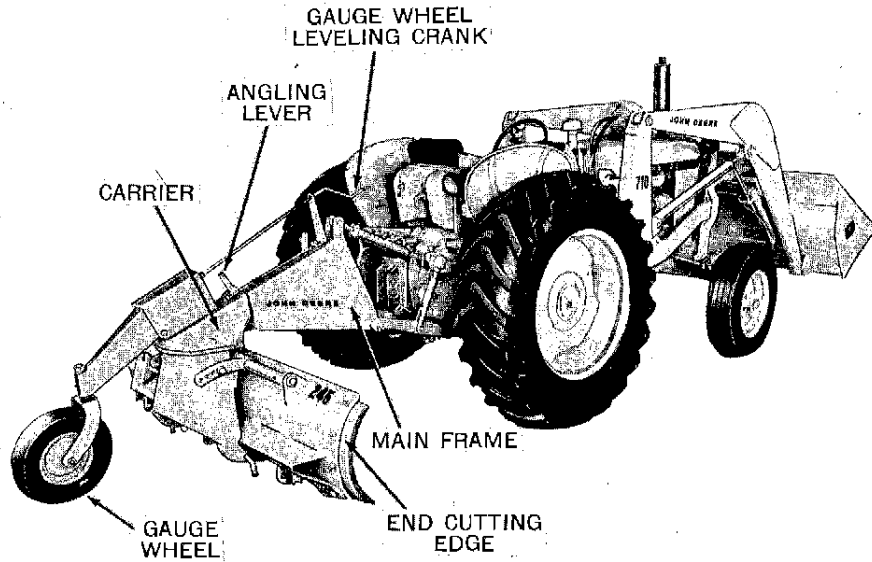

U 1842

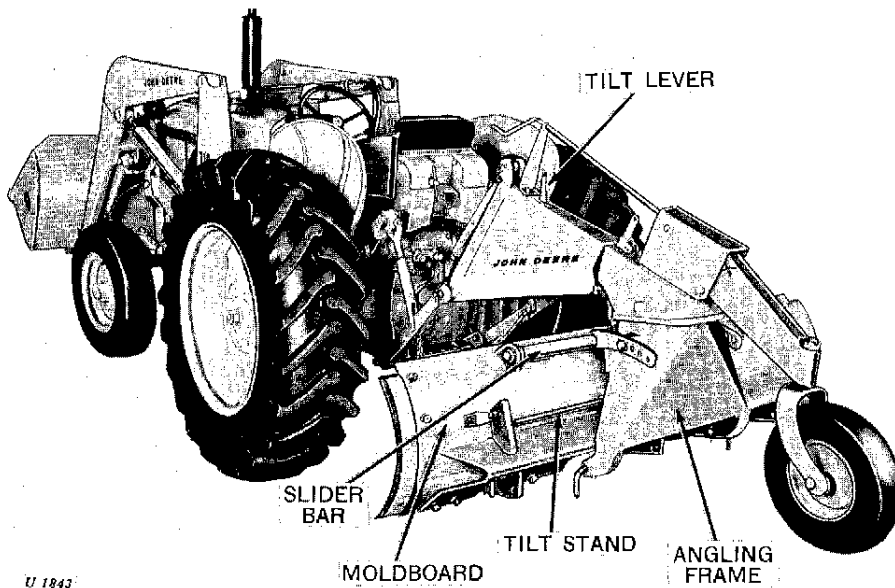

U 1843

*John Deere 245 heavy-duty rear blade used in conjunction with the John Deere 710 loader on John Deere 1010 wheel tractor*

Thank you so much for reading.  
Please click the “Buy Now!”  
button below to download the  
complete manual.



After you pay.

You can download the most  
perfect and complete manual in  
the world immediately.

Our support email:

[ebooklibonline@outlook.com](mailto:ebooklibonline@outlook.com)