

**X 331**  
**X 331E**  
**X 334**

**Excavator**

**Service  
Manual**

**331 (S/N 512913001 & Above)**  
**331E (S/N 517711001 & Above)**  
**334 (S/N 516711001 & Above)**

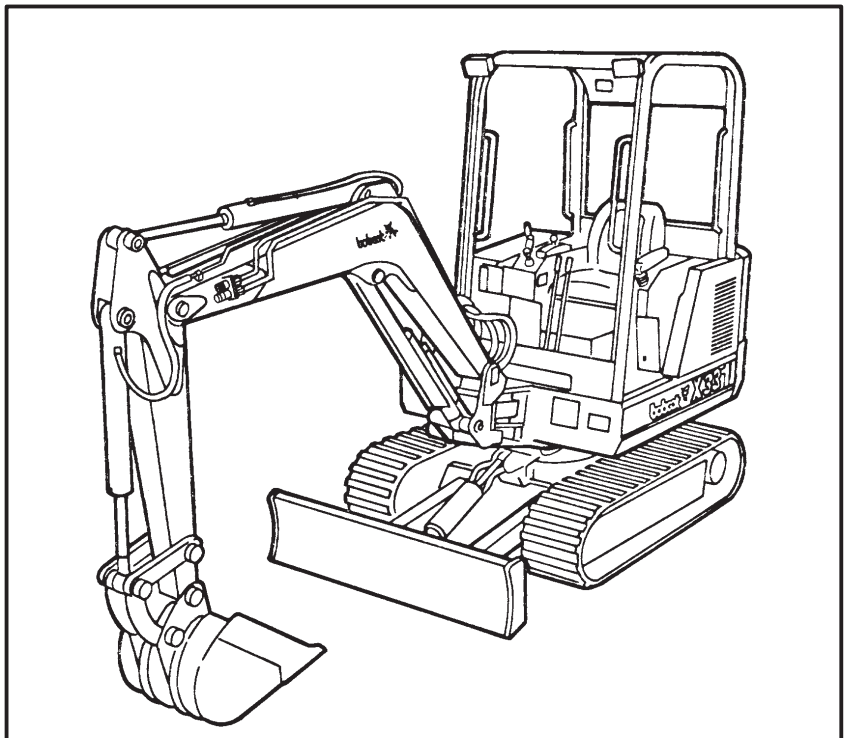

# CONTENTS

SAFETY INSTRUCTIONS .....	v
FOREWORD .....	iii
SERIAL NUMBER LOCATIONS .....	vi
DELIVERY REPORT .....	vi
MACHINE SIGNS TRANSLATIONS (Decals) .....	ix
HYDRAULIC EXCAVATOR IDENTIFICATION .....	viii
PREVENTIVE MAINTENANCE .....	1-1
HYDRAULIC SYSTEM .....	2-1
DRIVE SYSTEM .....	3-1
UPPER WORKS & SWING SECTION .....	4-1
MAIN FRAME & TRACKS .....	5-1
ELECTRICAL SYSTEM .....	6-1
ENGINE SERVICE .....	7-1
SPECIFICATIONS .....	8-1

**PREVENTIVE  
MAINTENANCE**

**HYDRAULIC  
SYSTEM**

**DRIVE  
SECTION**

**UPPER WORKS  
& SWING  
SECTION**

**MAIN FRAME  
& TRACKS**

**ELECTRICAL  
SYSTEM**

**ENGINE  
SERVICE**

**SPECIFICATIONS**

Thank you so much for reading.  
Please click the “Buy Now!”  
button below to download the  
complete manual.



After you pay.

You can download the most  
perfect and complete manual in  
the world immediately.

Our support email:

[ebooklibonline@outlook.com](mailto:ebooklibonline@outlook.com)