

**845B / 845B DHP**  
**865B / 865B VHP / 865B AWD**  
**885B / 885B DHP / 885B AWD**  
Grader

**SERVICE MANUAL**

**Part number 71114392**

English  
October 2011



## 667TA ENGINES

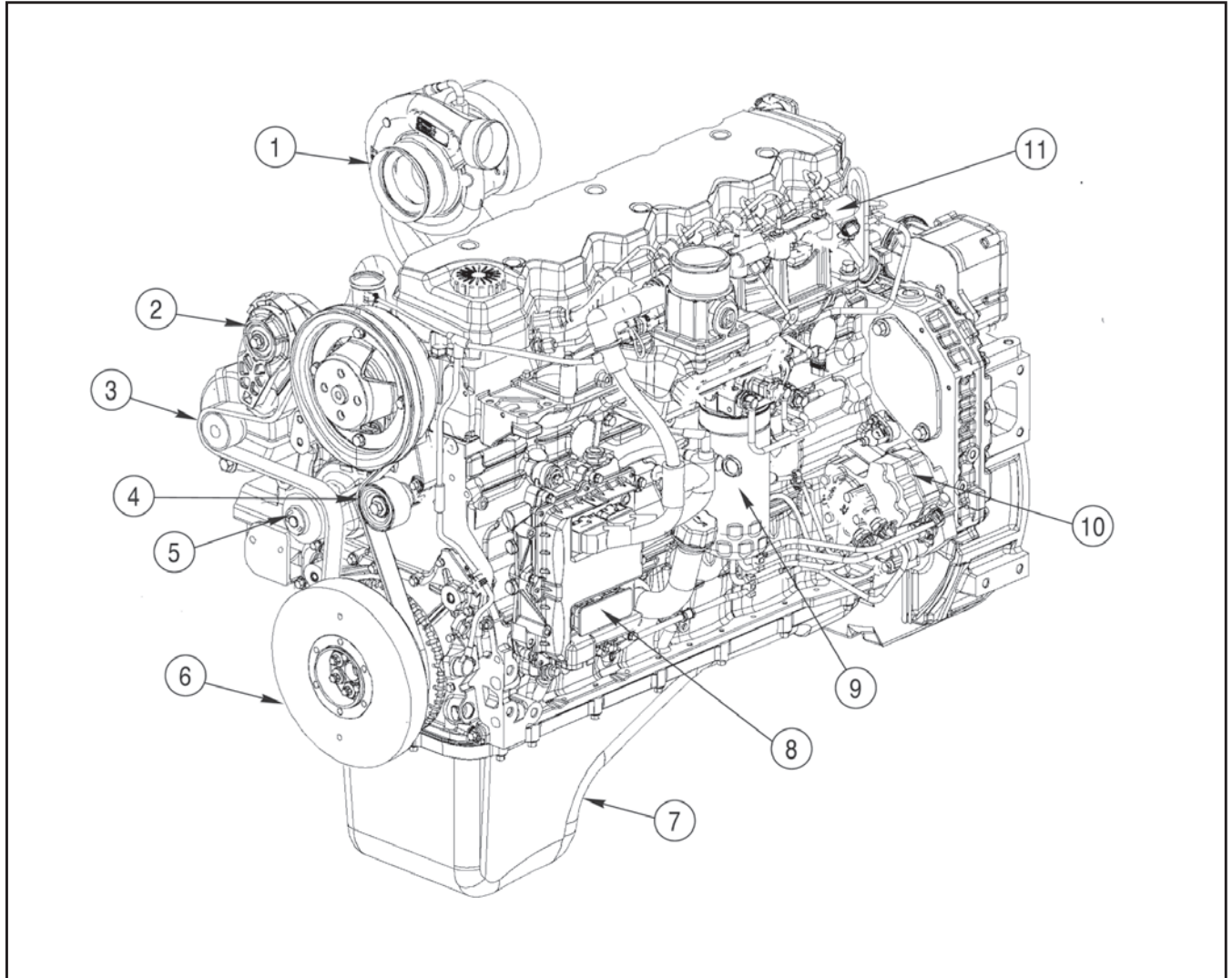

BS06K020

Figura 3000-12

1. TURBOCHARGER
2. AUTOMATIC TENSION BELT
3. ALTERNATOR
4. FIX GUIDE PULLEY
5. WATER PUMP
6. ENGINE FLYWHEEL COUNTERWEIGHT

7. OIL SUMP
8. ELECTRONIC CONTROL UNIT - E.C.U.
9. FUEL FILTER
10. HIGH PRESSURE PUMP
11. COMMON RAIL

## DESCRIPTION OF ENGINE MAIN COMPONENTS

### Engine Block

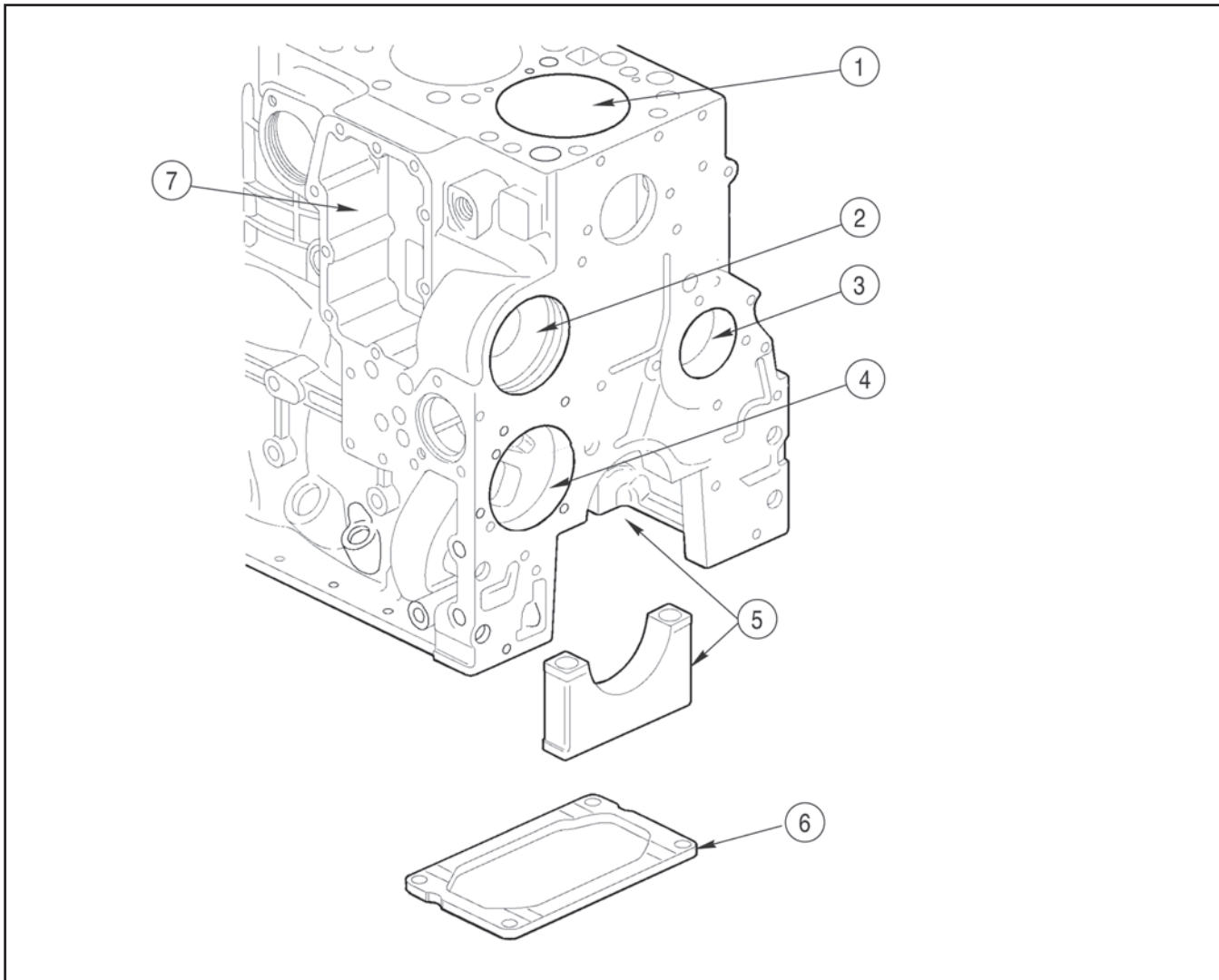

- |                                  |   |
|----------------------------------|---|
| 1. CYLINDER BORE                 | 5. MAIN JOURNALS                          |
| 2. MOUNTING FOR WATER PUMP       | 6. STIFFENING PLATE                       |
| 3. MOUNTING FOR CAMSHAFT BEARING | 7. MOUNTING FOR WATER-OIL EXCHANGE HEATER |
| 4. MOUNTING FOR OIL PUMP         |   |

The cylinder block is a cast iron structure with cylinders bores (1), main journals (5) e moun-tings for camshaft bearing (3) and valves, water-oil exchanger heater (7), water pump (2) and oil pump (4). The block also has coolant and oil passages. The lubrication circuit provides oil for the moving parts. The stiffening plate (6) is applied in the engine block bottom to increase the resistance to mechanical fatigue.

## Crankshaft

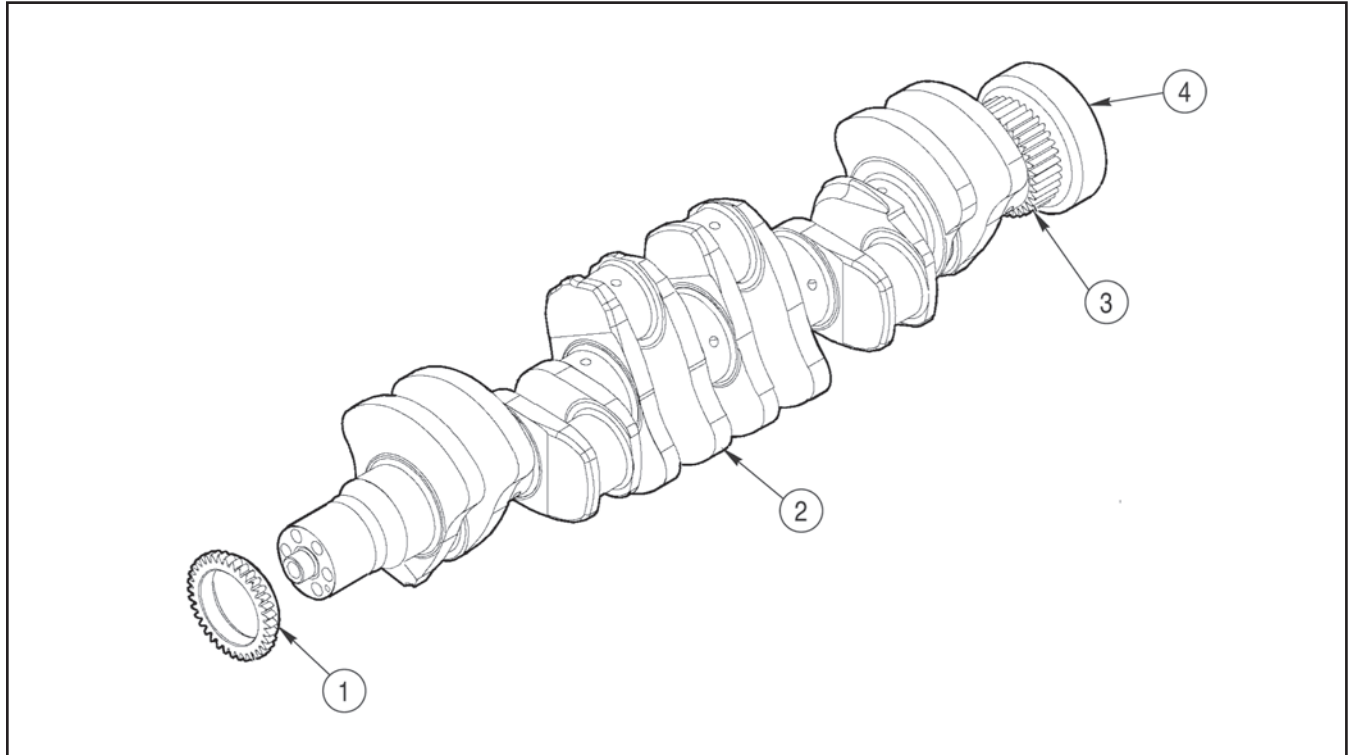

BS06K022

Figura 3000-14

- |                  |                                 |
|------------------|---------------------------------|
| 1. OIL PUMP GEAR | 3. TIMING GEAR                  |
| 2. CRANKSHAFT    | 4. MOUNTING FOR ENGINE FLYWHEEL |

The crankshaft is steel made and rests in seven journals tempered by induction.

There is a series of drilled passages for the lubricating oil.

The follow items are pressed in front: oil pump gear (1), position sensor sprocket, counterweight, and the auxiliary devices pulley.

The follow items are pressed in rear: timing gear (3), and the mounting for engine flywheel (4).

The main journals bearings are steel made and coated by a anti-friction alloy. One of them is equipped with shoulders to limit the crantckshaft axial clearance.

The timing gear (3) and the engine flywheel mounting (4) are forced positioned in the crantckshaft rear and can not be replaced.

### CRANCKSHAFT OIL SEALS

The front and rear seals are box type with radial sealing. To remove them use the special tools 380000665 e 380000663. For installation se special tools 380000666 e 380000664.

## Connecting Rod



BS06K023

Figura 3000-15

Connecting rods are forged steel. The big ends are made with an oblique angle. Caps and rods are separated by a fracture splitting method that produces a strong and unique fit cap. The connecting rod big end bearings are coated by anti-friction alloy.

They are marked two ways:

- Body-cap: have a number that indicates match and cylinder which they are assembled.
- Rod shank: marked with a letter indicating weight class.

Thank you so much for reading.  
Please click the “Buy Now!”  
button below to download the  
complete manual.



After you pay.

You can download the most  
perfect and complete manual in  
the world immediately.

Our support email:

[ebooklibonline@outlook.com](mailto:ebooklibonline@outlook.com)