

Product: WHEEL SKIDDER

Model: 508 WHEEL SKIDDER 2HD

Configuration: 508 SKIDDER AND GRAPPLE SKIDDER 2HD00001-UP (MACHINE) POWERED BY 3204 ENGINE

## Disassembly and Assembly 508 SKIDDER & 508 GRAPPLE SKIDDER POWER TRAIN

Media Number -SEN3366-01

Publication Date -01/11/2004

Date Updated -15/08/2005

SEN33660008

## Wheel And Wheel Spindles

SMCS - 4205-011; 4208

### Remove Wheels And Wheel Spindles

Tools Needed		A	B	C
6V2157	Link Bracket	1		
6V4074	Spanner Wrench		1	
1P520	Driver Group			1

Start By:

- a. remove tires and rims
- b. remove final drives

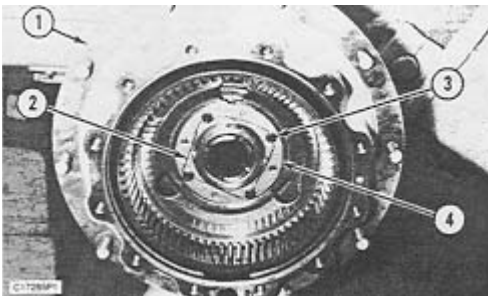

1. Remove lockwire (2), four bolts (3) and lockplate (4) from wheel assembly (1).

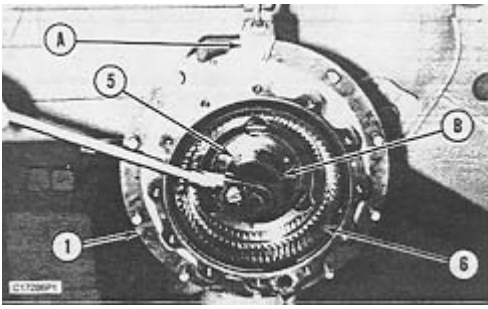

2. Fasten tool (A) and a hoist to wheel assembly (1) as shown.
3. Use tool (B), and remove nut (5) and gear assembly (6) from the spindle.
4. Remove wheel assembly (1) from the spindle. The weight of the wheel assembly is 84 kg (185 lb).

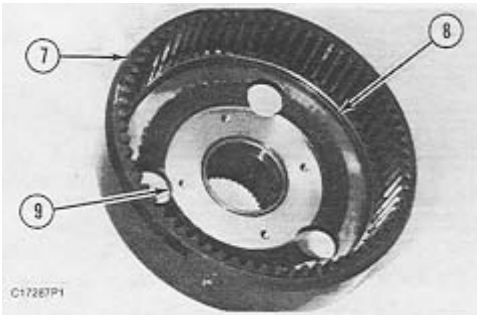

5. Remove retaining ring (8) that hold ring gear (7) to hub (9), and remove the ring gear.

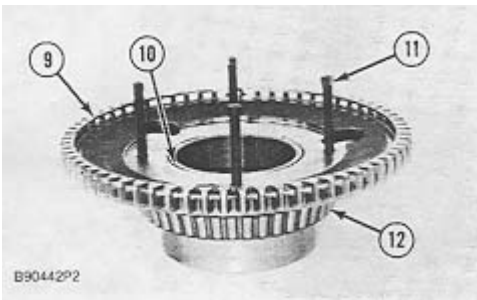

6. Install four 3/8" - 16 NC forcing screws (11), and remove bearing (12) from hub (9).
7. Use tooling (C) and a press to remove bushing (10) from hub (9).

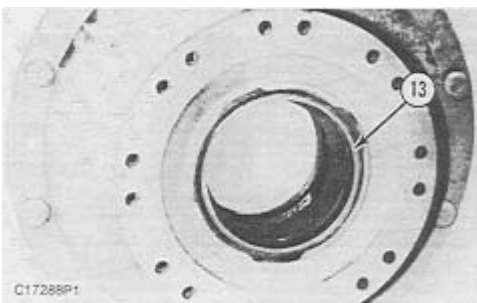

8. Remove Duo-Cone seal (13) from the wheel assembly.

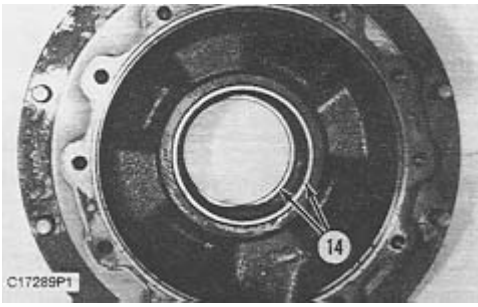

9. If necessary, remove bearing cups (14) from the wheel assembly.

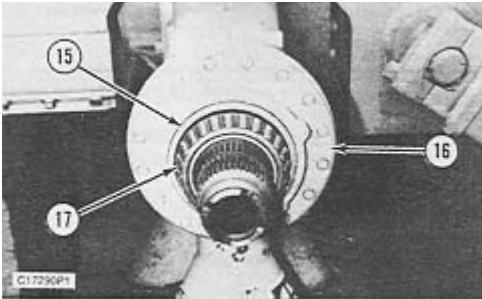

10. Remove Duo-Cone seal (15) and bearing cone (17) from spindle (16).

11. Remove the sixteen bolts and spindle (16) from the axle housing.

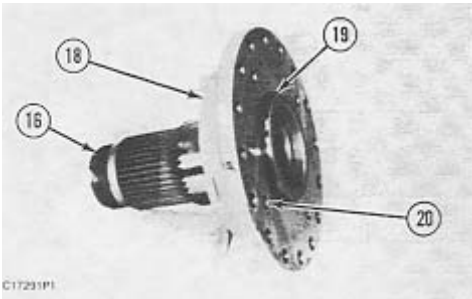

12. Remove four bolts (20) and retainer (18) from spindle (16). Remove the O-ring seal from retainer (18).

13. Remove O-ring seal (19) from spindle (16).

## Install Wheels And Wheel Spindles

Tools Needed		A	B	C	D
6V2157	Link Bracket	1			
6V4074	Spanner Wrench		1		
1P520	Driver Group			1	
5S4276	Duo-Cone Installation Tool				1

## **WARNING**

**Use caution when using isopropyl alcohol. Follow the manufacturer's recommendations on the container when using isopropyl alcohol.**

---

1. Clean and inspect all parts for wear or damage. Replace all parts that are damaged or worn.
2. Make sure all parts are free of oil film, dirt or other foreign material. Use isopropyl alcohol and a clean cloth or paper towel for cleaning.

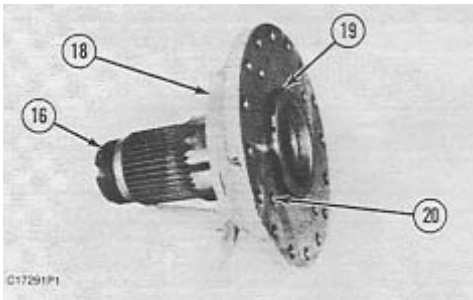

3. Install the O-ring seal on retainer (18).
4. Put retainer (18) in position on spindle (16), and install four bolts (20) that hold it in place.
5. Install O-ring seal (19) on spindle (16).

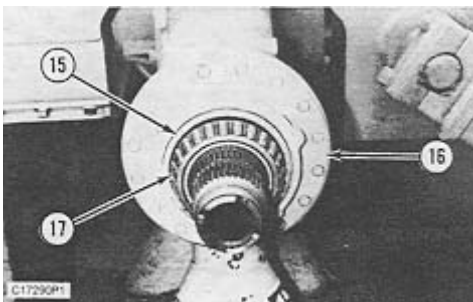

6. Put spindle (16) in position on the axle housing, and install the sixteen bolts that hold it in place. Tighten the bolts to a torque of  $270 \pm 25$  N·m ( $200 \pm 18$  lbft).

**NOTE:** See the topic, Installation Of Duo-Cone Floating Seals before installation of any of the Duo-Cone seals.

7. Install Duo-Cone seal (15) in the spindle retainer with tool (D).
8. Install bearing cone (17) on spindle (16).

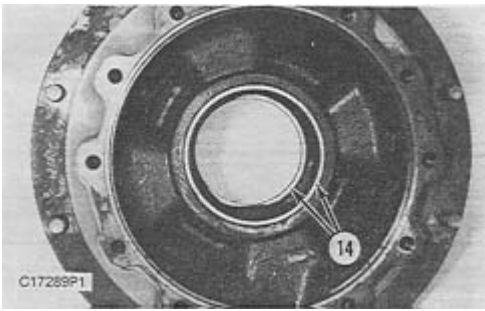

9. Lower the temperature of bearing caps (14), and install them in the wheel assembly.

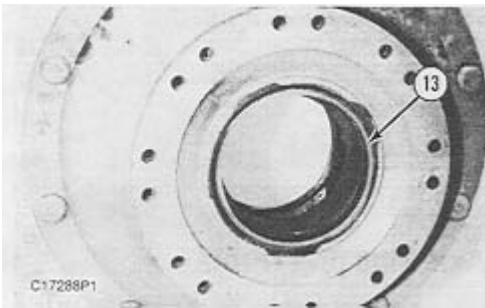

10. Install Duo-Cone seal (13) in the wheel assembly with tool (D).

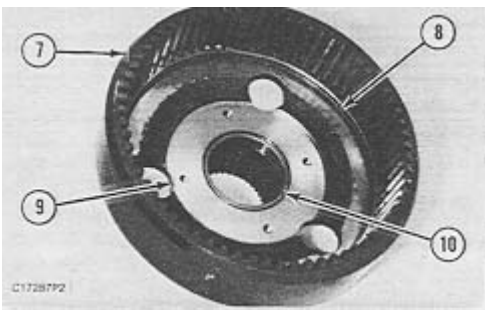

11. Use tooling (C) and a press to install bushing (10) in hub (9).

12. Put ring gear (7) in position on hub (9), and install retaining ring (8) that holds the ring gear on the hub.

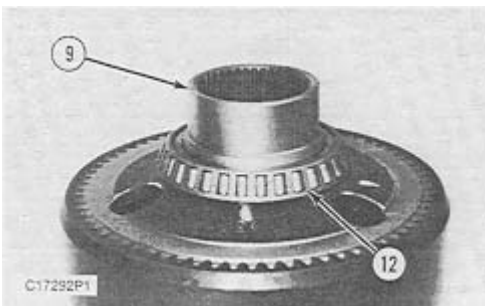

13. Install bearing cone (12) on hub (9).

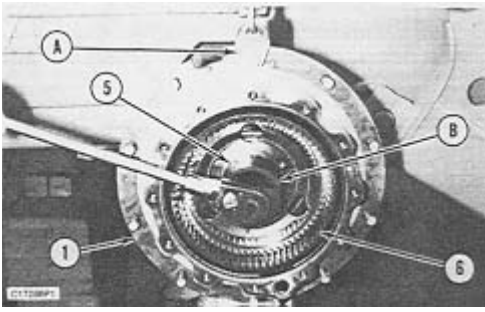

**14.** Use the following procedure to assemble the wheel assembly and obtain the proper wheel bearing preload:

- a.** Use tool (A) and a hoist to install wheel assembly (1) on the spindle.
- b.** Install gear assembly (6) on the spindle.
- c.** Install nut (5) loosely on the spindle with tool (B).
- d.** Rotate the wheel assembly to seat the wheel bearing rollers against the cone back face rib.

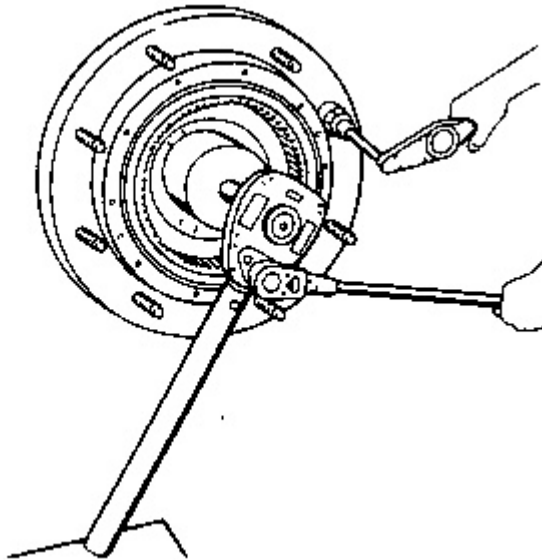

**e.** Use tool (B) to tighten nut (5) while rotating the wheel assembly. Tighten the nut to 600 N·m (440 lbft) to seat the parts.

**f.** Loosen nut (5) with tool (B).

**g.** Check the rolling torque due to the Duo-Cone seal drag.

**h.** Use tool (B) to tighten nut (5) while rotating the wheel assembly. Tighten the nut to a torque of 150 N·m (110 lbft).

**i.** Move nut (5) to the nearest lockring position (tighten or loosen).

**j.** Tighten nut (5) 1/8 turn (45 degrees).

**k.** Check the rolling torque due to wheel bearing preload, by subtracting the rolling torque due to the Duo-Cone seal drag (Step g).

**I.** Rolling torque, due to bearing preload, should be 18 N·m (13 lb ft), or if using a 203 mm (8 in) long torque wrench preload should be 8.5 N·m (76 lbin).

**NOTE:** To obtain the correct torque reading using other N·m (lbin) torque wrenches, see the topic, Adjustment Of Wheel Bearings in Testing And Adjusting, Form No. SENR3365.

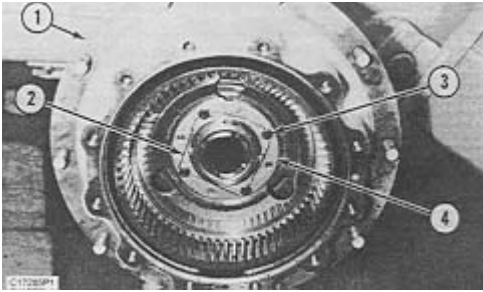

**15.** Install lockplate (4) on the nut.

**16.** Install four bolts (3) that hold the lockplate.

**17.** Install lockwire (2) through bolts (3).

End By:

**a.** install final drives

**b.** install tires and rims

---

Product: WHEEL SKIDDER

Model: 508 WHEEL SKIDDER 2HD

Configuration: 508 SKIDDER AND GRAPPLE SKIDDER 2HD00001-UP (MACHINE) POWERED BY 3204 ENGINE

## Disassembly and Assembly 508 SKIDDER & 508 GRAPPLE SKIDDER POWER TRAIN

Media Number -SEN3366-01

Publication Date -01/11/2004

Date Updated -15/08/2005

SEN33660009

### Axle Housing (Front)

SMCS - 3260-010

### Remove And Install Axle Housing (Front)

Tools Needed		A	B
6V2156	Link Bracket	2	
8S9906	Ratchet Puller	2	
FT1439	Lifting Beam	1	
8S7640	Stand		2
8S7621	Tube		2
8S7615	Pin		2

Start By:

- a. remove drive shaft (front)



**WARNING**

**Make sure machine is on a hard, level surface. Block the front tires to prevent movement of the machine.**

1. Drain the oil from the front axle housing.

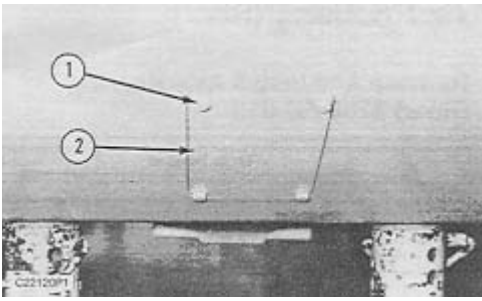

2. Remove four bolts (1) and plate (2) from the front frame.

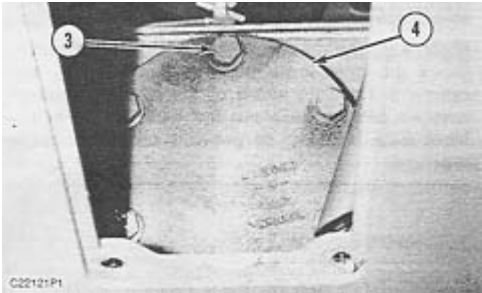

3. Remove six bolts (3) and cover (4) from the front frame.

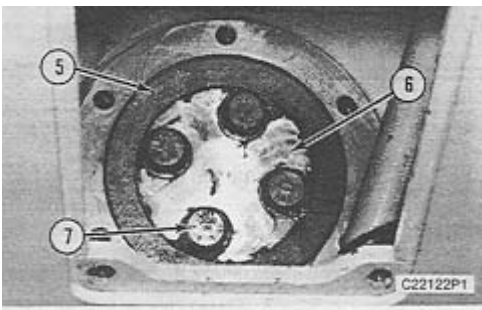

4. Remove washer (5), four bolts (7), plate (6) and the washer from the trunnion.

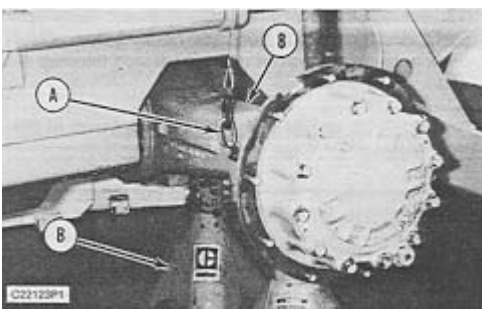

5. Raise the front of the machine, and position tooling (B) as shown.

6. Remove both front tires and rims. See the topic, Remove Tires And Rims, in this module for the remaining steps.

7. Attach tooling (A) and a hoist to front axle housing (8) as shown.

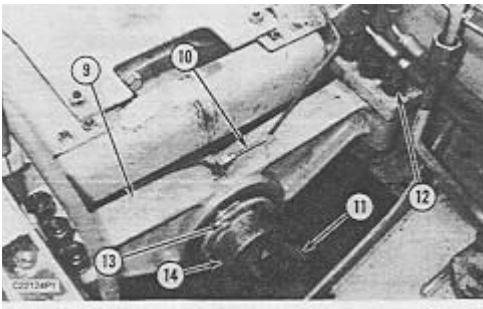

**NOTE:** For better photographic illustrations, the engine and transmission have been removed.

8. Disconnect tube assembly (10) from support (9).
9. Remove yoke (11) from the front axle housing.
10. Remove two bolts (13) that hold housing (14) in place. Temporarily install two larger diameter flat washers and the bolts. The flat washers must extend beyond the outside diameter housing (14) to prevent support (9) from sliding off while removing the front axle housing.
11. Remove six bolts and nuts (12) that fasten support (9) to the frame.
12. Move the front axle housing toward the back of the machine until the trunnion on the front of the axle housing clears the frame.
13. Position the front axle housing on two suitable floor jacks, and remove the front axle housing from under the machine. The weight of the front axle housing is 590 kg (1,1300 lb).

**NOTE:** The following steps are for installation of the front axle housing.

14. Use two suitable floor jacks to put the front axle housing in position under the machine.
15. Attach tooling (A) and a hoist to front axle housing (8).
16. Raise the front axle housing, and move it toward the front of the machine to install the trunnion in the frame.
17. Install six bolts and nuts (12) that fasten support (9) to the frame. Tighten the bolts and nuts to a torque of  $750 \pm 80 \text{ N}\cdot\text{m}$  ( $550 \pm 60 \text{ lb ft}$ ).
18. Remove the two bolts and large flat washers that were installed to hold support (9) on the front axle housing. Install the two original bolts and washers.
19. Install yoke (11) on the front axle housing.
20. Connect tube assembly (10) to support (9).
21. Install both front tires and rims. See the topic, Install Tires And Rims, in this module.
22. Raise the front of the machine, and remove tooling (B).
23. Install the washer, plate (6), four bolts (7) and washer (5) on the trunnion.
24. Install cover (4) and six bolts (3) on the front frame.
25. Install plate (2) and four bolts (1) on the front frame.

**26.** Fill the front axle housing with oil. See the Maintenance Guide.

End By:

**a.** install drive shaft (front)

---

Product: WHEEL SKIDDER

Model: 508 WHEEL SKIDDER 2HD

Configuration: 508 SKIDDER AND GRAPPLE SKIDDER 2HD00001-UP (MACHINE) POWERED BY 3204 ENGINE

## Disassembly and Assembly 508 SKIDDER & 508 GRAPPLE SKIDDER POWER TRAIN

Media Number -SEN3366-01

Publication Date -01/11/2004

Date Updated -15/08/2005

SEN33660010

### Axle Housing (Rear)

SMCS - 3260-010

### Remove And Install Axle Housing (Rear)

Tools Needed		A
6V2157	Link Bracket	2
8S9906	Ratchet Puller	2
FT1439	Lifting Beam	1

Start By:

- a. connection of steering frame lock link



**Make sure the machine is on a hard, level surface. Block the front tires to prevent movement of the machine. On both sides of the machine, position wooden blocks between the front frame and the front axle housing to prevent oscillation of the machine.**

1. Drain the fuel from the fuel tank.
2. Drain the oil from the rear axle housing.
3. Remove the rear bottom guard. The weight of the rear bottom guard is 38 Kg (84 lb).

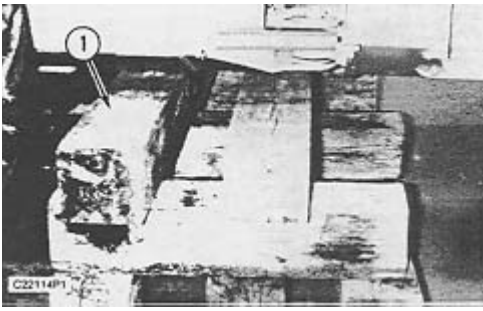

**4.** Raise the rear of the machine, and position wooden blocks (1) under the rear frame as shown.

**5.** Remove both rear tires and rims. See the topic, Remove Tires And Rims in this module for the remaining steps.

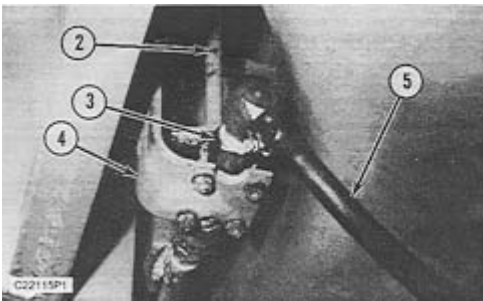

**6.** Loosen the hose clamp, and remove hose (5) from fuel drain valve (3).

**7.** Remove the two nuts and screws that fasten tube assembly (2) to fuel drain valve (3).

**8.** Remove the two bolts that fasten bracket (4) to the rear frame. Move the fuel drain valve away from the rear axle housing.

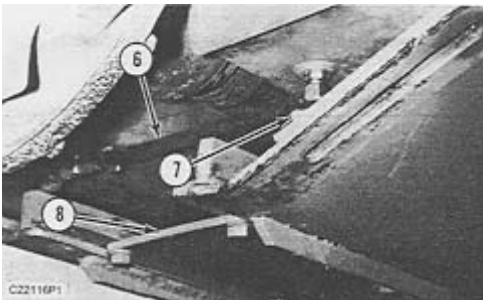

**9.** Loosen hose clamp (7), and remove hose (6) from the right side of the fuel tank.

**10.** Remove the four bolts and plate (8).

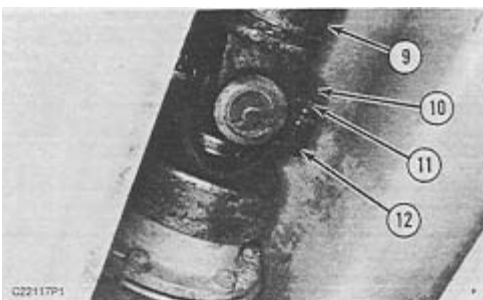

**11.** Remove four bolts (11) and two straps (10), and slide yoke (12) away from drive shaft (9).

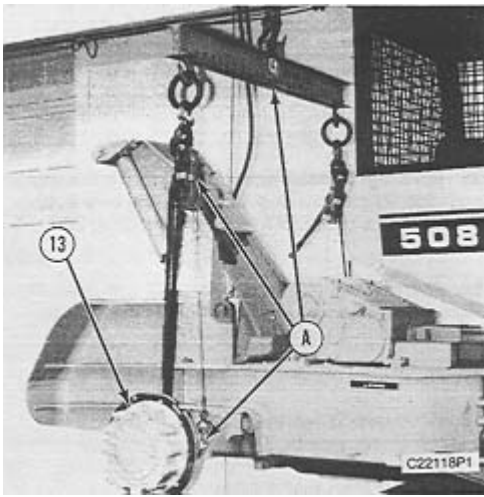

**12.** Attach tooling (A) and a hoist to rear axle housing (13) as shown.

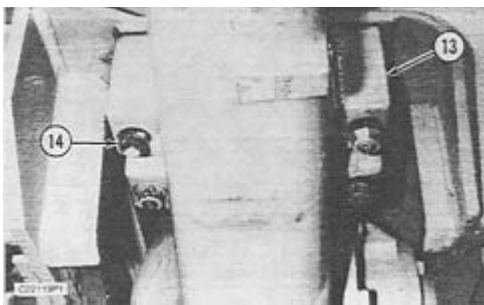

**13.** Remove eight nuts and bolts (14), and lower rear axle housing (13). Remove the rear axle housing from under the machine. The weight of the rear axle housing is 590 Kg (1,300 lb).

**NOTE:** The following steps are for installation of the rear axle housing.

**14.** Use tooling (A) and a hoist to position rear axle housing (13) under the machine.

**15.** Raise the rear axle housing against the rear frame, and install eight bolts and nuts (14). Tighten the nuts and bolts to a torque of  $475 \pm 50 \text{ N}\cdot\text{m}$  ( $350 \pm 37 \text{ lbft}$ ).

**16.** Position yoke (12) on drive shaft (9), and install two straps (10) and four bolts (11). Tighten the bolts to a torque of  $60 \pm 7 \text{ N}\cdot\text{m}$  ( $44 \pm 5 \text{ lbft}$ ).

**17.** Install plate (8) and the four bolts.

**18.** Install hose (6) on the right side of the fuel tank, and tighten hose clamp (7).

**19.** Install bracket (4) on the rear frame.

**20.** Install tube assembly (2) on fuel drain valve (3).

**21.** Install hose (5) on the fuel drain valve, and tighten the hose clamp.

**22.** Install both rear tires and rims. See the topic, Install Tires And Rims in this module.

**23.** Raise the rear of the machine, and remove wooden blocks (1).

**24.** Install the rear bottom guard.

**25.** Fill the rear axle housing with oil. See the Maintenance Guide.

**26.** Fill the fuel tank with clean fuel.

**27.** Remove the blocks from the front tires.

**28.** Remove the wooden blocks from between the front axle housing and the front frame.

End By:

**a.** separation of steering frame lock link

---

Thank you so much for reading.  
Please click the “Buy Now!”  
button below to download the  
complete manual.



After you pay.

You can download the most  
perfect and complete manual in  
the world immediately.

Our support email:

[ebooklibonline@outlook.com](mailto:ebooklibonline@outlook.com)