

Product: WHEEL DOZER

Model: 854K WHEEL DOZER KK3

Configuration: 854K Wheel Dozer KK300001-UP (MACHINE) POWERED BY C32 Engine

Disassembly and Assembly 992K Wheel Loader and 854K Wheel Dozer Power Train

Media Number -REN8912-03

Publication Date -01/02/2008

Date Updated -16/08/2018

i02927088

Torque Converter - Assemble

SMCS - 3101-016

Assembly Procedure

Table 1

Required Tools			
Tool	Part Number	Part Description	Qty
B	138-7574	Link Bracket	2
C	138-7573	Link Bracket	3
F	0S-1614	Bolt	1
	5P-0537	Hard Washer	1
G	9X-8876	Bolt	2
	1F-7958	Nut	2
H	138-7575	Link Bracket	3
J	2D-1201	Eyebolt	1
K	1P-0520	Driver Gp	1
L	8T-5096	Dial Indicator Gp	1
M	5P-2390	Gauge Tool Gp	1

NOTICE

Keep all parts clean from contaminants.

Contaminants may cause rapid wear and shortened component life.

Note: Check the O-ring seals, the gaskets, and the seals for wear or for damage. Replace the components, if necessary.

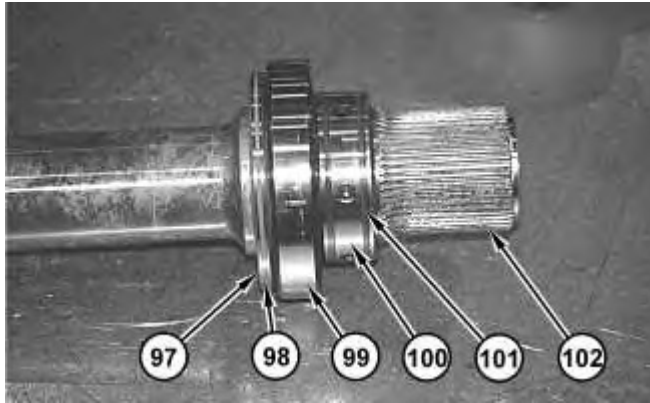

Illustration 1

g01452846

1. Raise the temperature of seal carrier (97). Install seal carrier (97) onto shaft (102).
2. Lubricate seal (98) with the oil that is being sealed. Install seal (98) on seal carrier (97).
3. Raise the temperature of bearing (99). Install bearing (99) onto shaft (102).
4. Raise the temperature of seal carrier (100). Install seal carrier (100) onto shaft (102).
5. Lubricate seals (101) with the lubricant that is being sealed. Install seals (101) onto seal carrier (100).

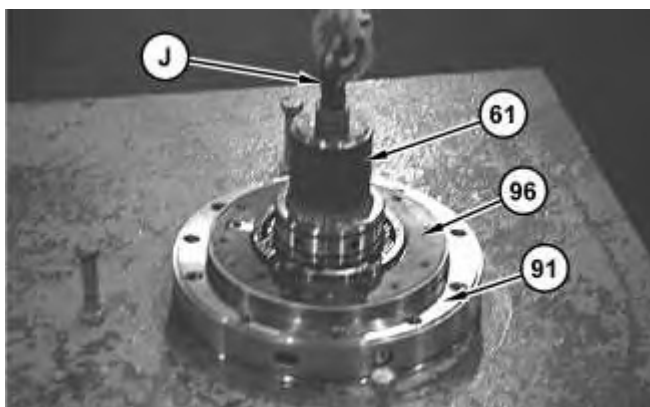

Illustration 2

g01452840

6. Attach Tooling (J) and a suitable lifting device to shaft assembly (61). The weight of shaft assembly (61) is approximately 26 kg (57 lb). Use Tooling (J) and the suitable lifting device in order to install shaft assembly (61) onto carrier assembly (91). Install gasket (96).
-

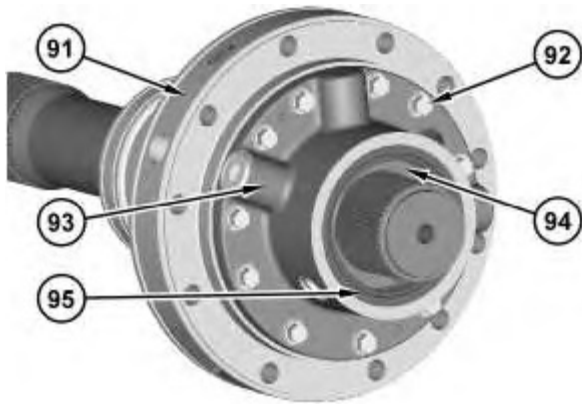

Illustration 3

g01452836

7. Reposition carrier assembly (91). The combined weight of carrier assembly (91) and the shaft assembly is approximately 34 kg (75 lb).
8. Install spacer (94) onto the shaft assembly.
9. Install lip seal (95) into bearing cage (93). Position bearing cage (93). Install bolts (92). Tighten bolts (92) to a torque of $50 \pm 7 \text{ N}\cdot\text{m}$ ($37 \pm 5 \text{ lb ft}$).

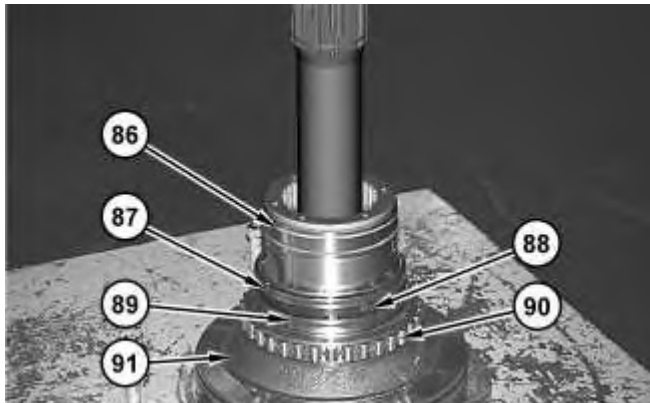

Illustration 4

g01452833



Illustration 5

g01127577

10. Reposition carrier assembly (91). The weight of carrier assembly (91) is approximately 79 kg (175 lb). Raise the temperature of bearing (90). Install bearing (90) onto carrier assembly (91).
11. Raise the temperature of seal carrier (87). Install seal carrier (87).
Note: Make sure that the Holes (X) in seal carrier (87) are in alignment with Holes (Y) in the shaft.
12. Install locator pin (88).
13. Install seals (86) and (89).



Illustration 6

g01452827

14. Install bearing race (85) in gear (83) and gear (84). Use two people in order to install gears (84) and (83). The combined weight of gear (83) and gear (84) is approximately 36 kg (80 lb). Install bolts (82). Tighten bolts (82) to a torque of 240 ± 25 N·m (175 ± 18 lb ft).

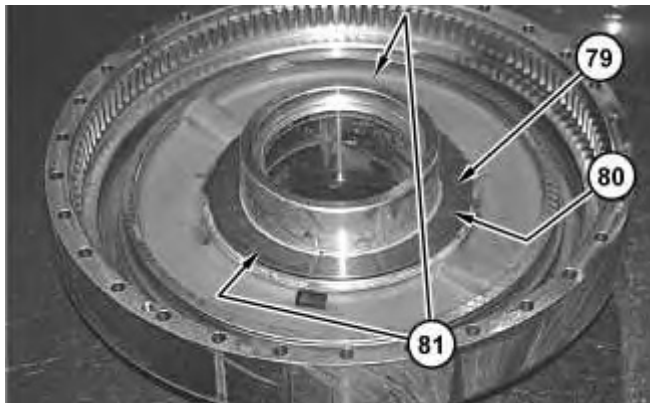

Illustration 7

g01452822

15. Install two dowel pins (81) (not shown). Install plate (80) (not shown). Install thrust washer (79).
-

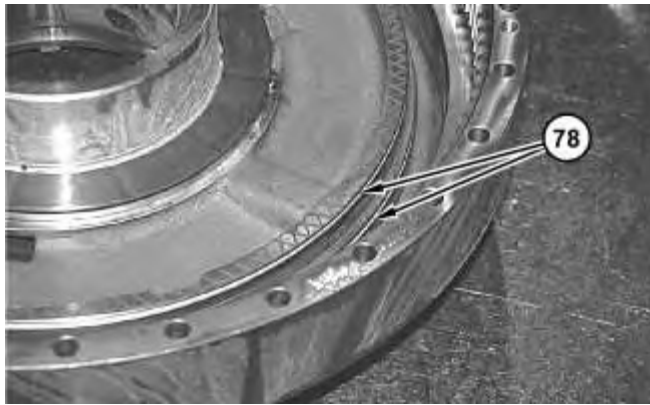

Illustration 8

g01452817

16. Lubricate seals (78) with oil that is being sealed. Install seals (78).



Illustration 9

g01452810

17. Install piston (77).

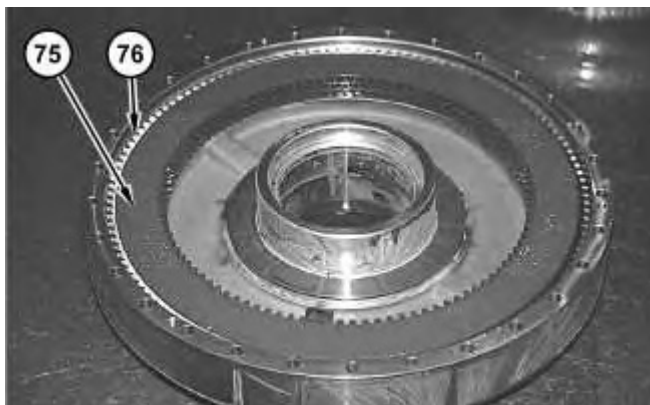

Illustration 10

g01452805

18. Install discs (75) and plates (76).



Illustration 11

g01452792

19. Attach Tooling (C) and a suitable lifting device to backing plate (74). The weight of backing plate (74) is approximately 25 kg (55 lb). Install backing plate (74) onto housing assembly (63).

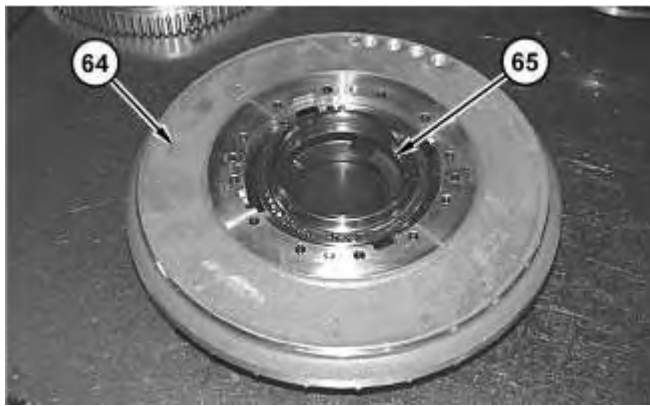

Illustration 12

g01452783

20. Install impeller hub (65) on impeller (64).



Illustration 13

g01452774

21. Install sleeve bearing (72).

22. Use two people in order to install adapter (73). The weight of adapter (73) is approximately 25 kg (55 lb). Install twelve bolts (71) (not shown). Tighten bolts (71) to a torque of $120 \pm 15 \text{ N}\cdot\text{m}$ ($89 \pm 11 \text{ lb ft}$).
23. Install four dowel pins (70) (not shown) that are located under plate (69). The correct height for dowel pins (70) is $3.10 \pm 0.13 \text{ mm}$ ($0.122 \pm 0.005 \text{ inch}$). Install plate (69).

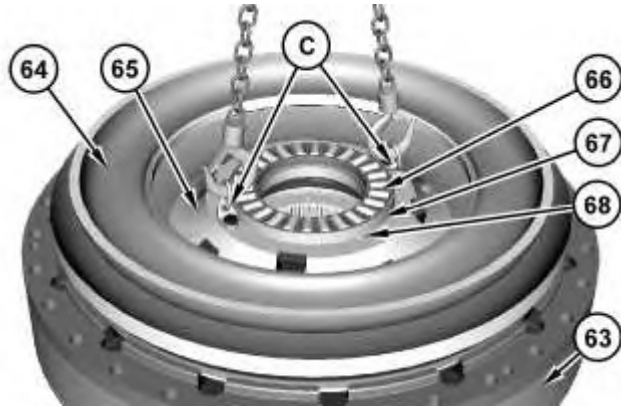

Illustration 14

g01452764

24. Install pins (68) and sleeve (67). Install thrust bearing (66).
25. Attach Tooling (C) and a suitable lifting device to impeller hub (65). The combined weight of impeller (64) and impeller hub (65) is approximately 57 kg (125 lb). Align the splines and install impeller (64) and impeller hub (65) on housing assembly (63).

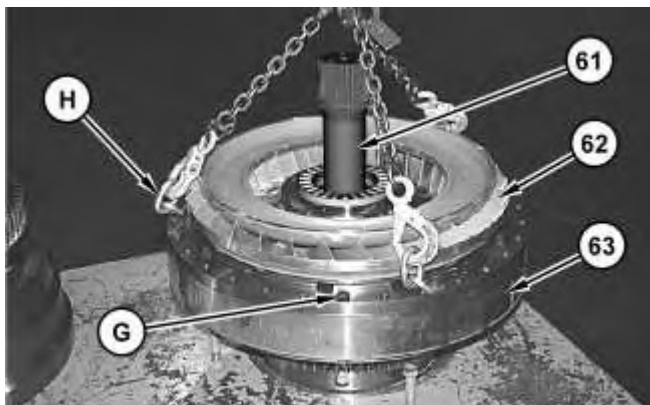

Illustration 15

g01452758

26. Install Tooling (G) in order to hold housing assembly (63) to the backing plate. Attach Tooling (H) and a suitable lifting device to the backing plate. The combined weight of housing assembly (63), impeller clutch (62), and the backing plate is approximately 181 kg (400 lb). Install housing assembly (63), impeller clutch (62), and the backing plate onto shaft assembly (61).
 27. Remove Tooling (G) that held housing (63) to the backing plate.
-

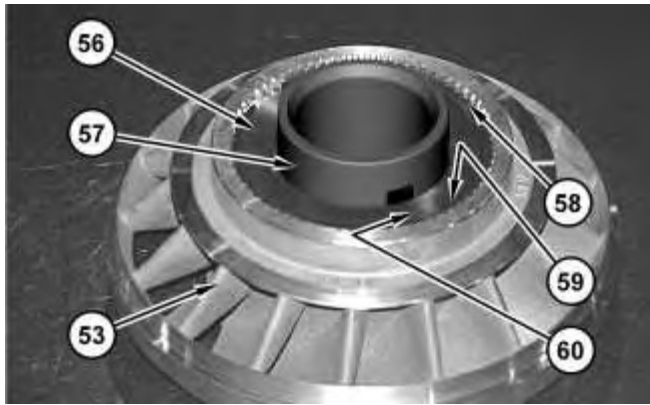

Illustration 16

g01452868

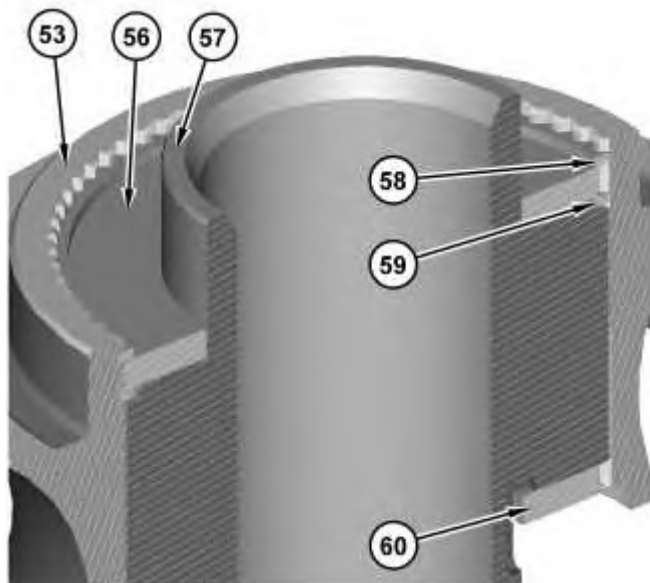

Illustration 17

g01452743

28. Install retaining ring (59) (not shown).
29. Lower the temperature of carrier (57). Use Tooling (K) and a suitable press in order to install carrier (57) into stator assembly (53).
30. Install plate (60) (not shown). Install plate (56). Install retaining ring (58).

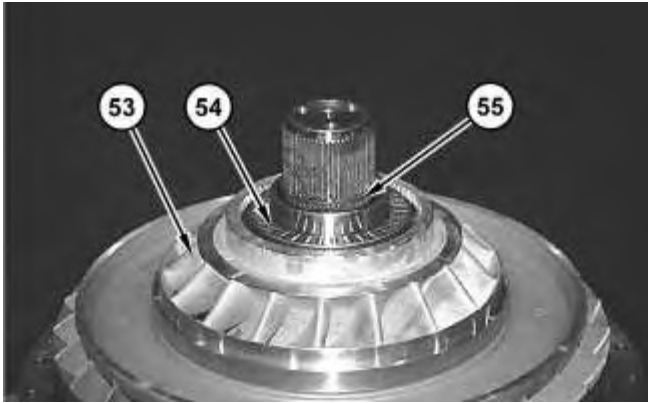

Illustration 18

g01452734

31. Install the carrier and stator assembly (53). Install thrust bearing (54) and retaining ring (55).

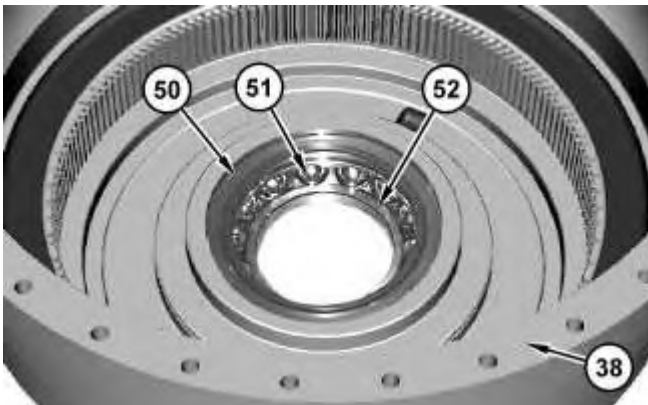

Illustration 19

g01452703

32. Install sleeve (50) into clutch housing assembly (38). Install race (52) and bearing (51).

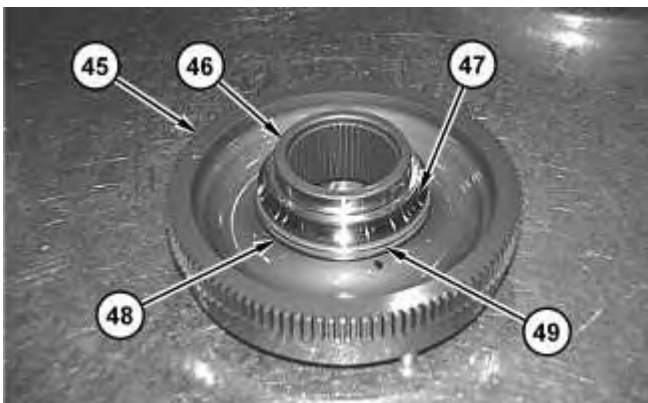

Illustration 20

g01452696

33. Install sleeve bearing (46).
34. Install seal carrier (48) and seal (49).

35. Install race (47).

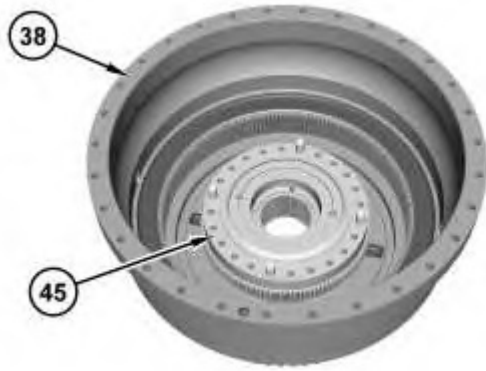

Illustration 21

g01452691

36. Install turbine hub assembly (45) into clutch housing assembly (38).

37. Install Tooling (F) in order to hold the turbine assembly together. Refer to Illustration 24 below.

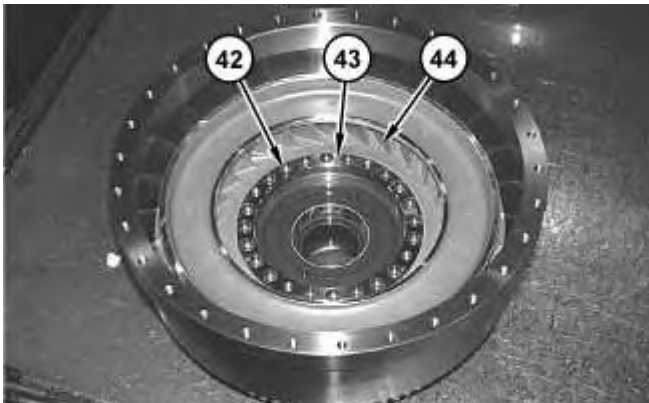
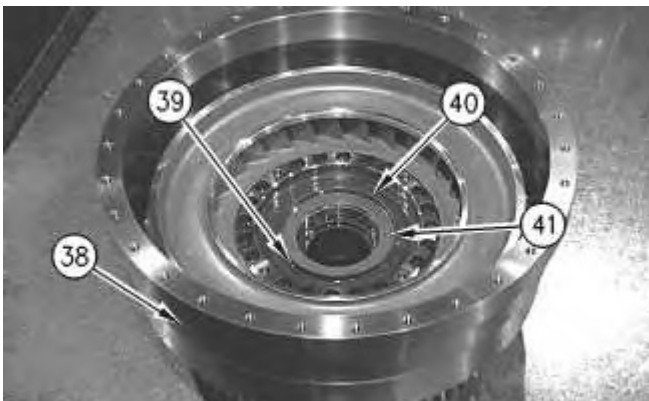

Illustration 22

g01450685

38. Install turbine (44). Install clamping plate (43) and bolts (42). Tighten bolts (42) to a torque of 120 ± 15 N·m (89 ± 11 lb ft).



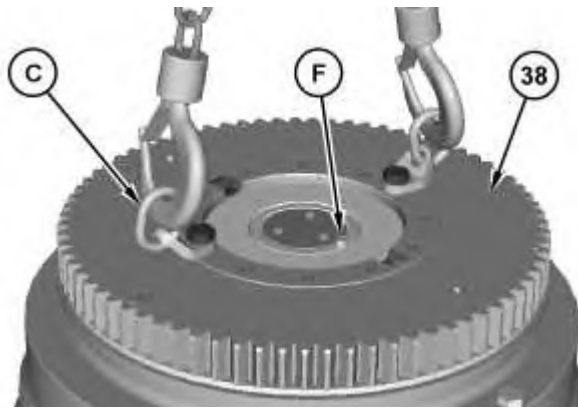

Illustration 24

39. Install pins (39), sleeve (40) and bearing race (41). Reposition clutch housing assembly (38) onto the opposite side for assembly purposes. The weight of clutch housing assembly (38) is approximately 168 kg (370 lb).
40. Attach Tooling (C) and a suitable lifting device to clutch housing assembly (38). Install clutch housing assembly (38). Remove Tooling (F) that is used to prevent the turbine assembly from separating away from the bearing.

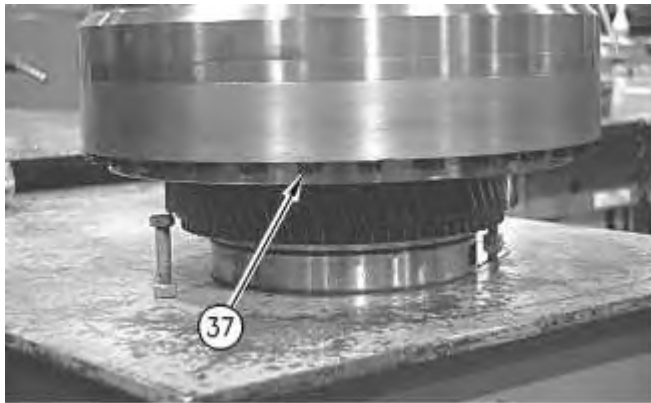

Illustration 25

41. Install bolts (37). Tighten bolts (37) to a torque of 120 ± 15 N·m (89 ± 11 lb ft).
-

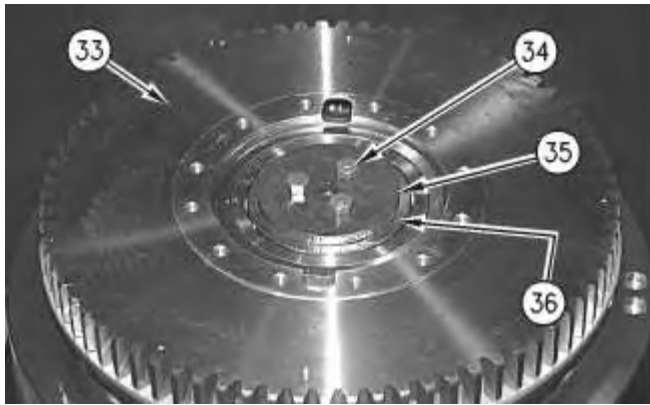

Illustration 26

g00357612

42. Install washer (36) (not shown), retainer (35), and bolts (34) onto torque converter assembly (33). Tighten bolts (34) to a torque of 120 ± 15 N·m (89 ± 11 lb ft).



Illustration 27

g01451779

43. Position torque converter assembly (33), as shown. The weight of torque converter assembly (33) is approximately 590 kg (1300 lb). Install pilot guide (32) on torque converter assembly (33). Install bolts (31). Tighten bolts (31) to a torque of 120 ± 15 N·m (89 ± 11 lb ft).

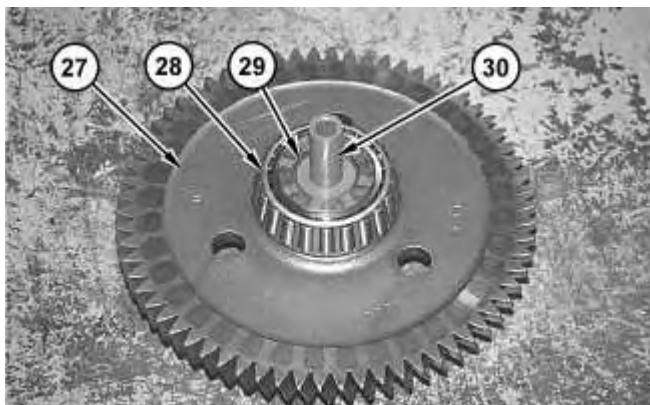

Illustration 28

g01450567

44. Install spline adapter (30), the O-ring seal, bearing cones (28) and retaining ring (29) onto pump drive gear (27).



Illustration 29

g01450430

45. Use two people in order to install pump drive gear (27). The weight of pump drive gear (27) is approximately 27 kg (60 lb). Install all of the shims.

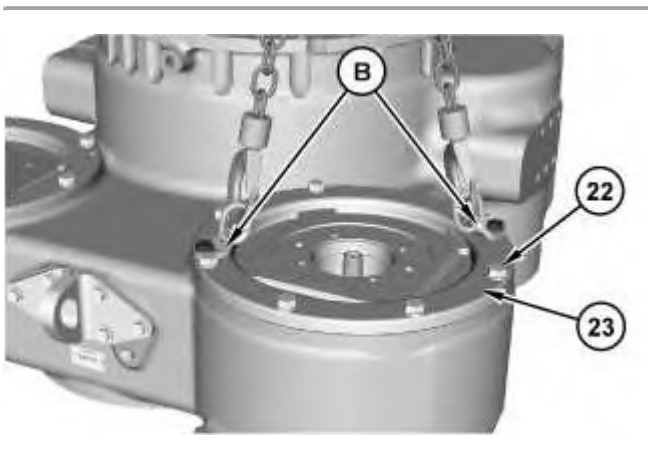

Illustration 30

g01452988

46. Lower the temperature of bearing cup (25). Install bearing cup (25) into pump adapter (23).

Note: Do not install the seals for the pump adapters at this time.



47. Attach Tooling (B) and a suitable lifting device to pump adapter (23). Install pump adapter (23) and bolts (22). Tighten bolts (22) to a torque of 240 ± 40 N·m (177 ± 30 lb ft).
48. When possible, rotate either the torque converter or the outer housing in order to ensure that the bearings are properly seated.

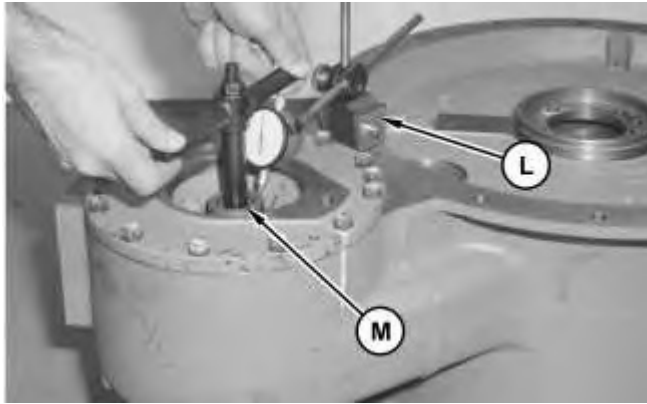

Illustration 32

49. Use Tooling (L) and Tooling (M) in order to check bearing end play. The bearing end play must be 0.10 ± 0.05 mm (0.004 ± 0.002 inch). Remove the shims that were installed in Step 45 in order to obtain the correct bearing end play, as needed.
50. Remove the pump adapter from the housing assembly.



Illustration 33

51. Install O-ring seals (26) onto pump adapter (23).
-

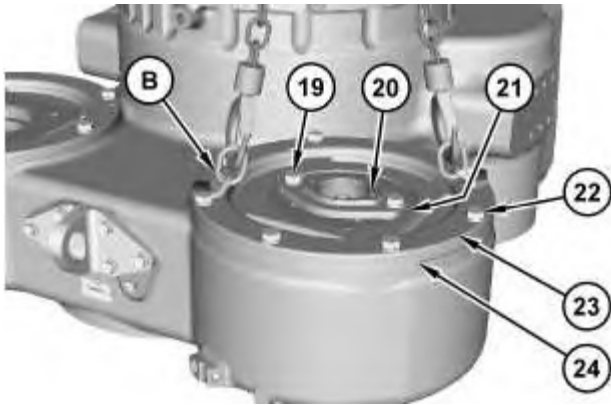

Illustration 34

g01451609

52. Install the correct amount of shims (24) onto the housing assembly. The correct amount of shims (24) were determined in Step 49.
53. Use Tooling (B) and a suitable lifting device in order to install pump adapter (23) on the housing assembly. Install bolts (22). Tighten bolts (22) to a torque of $240 \pm 40 \text{ N}\cdot\text{m}$ ($177 \pm 30 \text{ lb ft}$).
54. When possible, rotate either the torque converter housing or the outer housing in order to ensure that the bearings are properly seated. Use Tooling (L) and Tooling (M) in order to recheck the bearing end play. Repeat the above procedures, if necessary.
55. Repeat Steps 45 through 53 in order to install the remaining pump adapter.

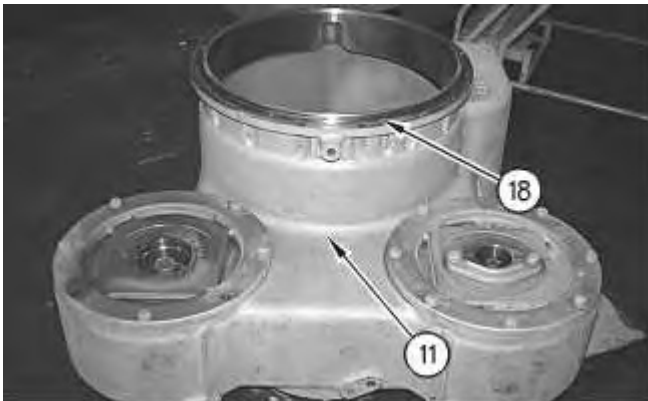

Illustration 35

g00357394

56. Install O-ring seal (18). Turn housing assembly (11) onto the opposite side. The weight of housing assembly (11) is approximately 680 kg (1500 lb).



Illustration 36

g00357392

57. Lower the temperature of bearing cup (17). Install bearing cup (17) in the housing assembly.

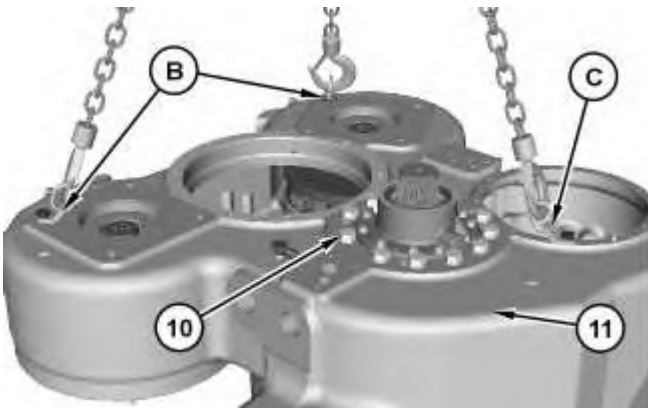

Illustration 37

g01451665

58. Attach Tooling (B), Tooling (C), and a suitable lifting device to housing assembly (11). The weight of housing assembly (11) is approximately 680 kg (1500 lb). Install housing assembly (11) onto the torque converter. Install bolts (10).

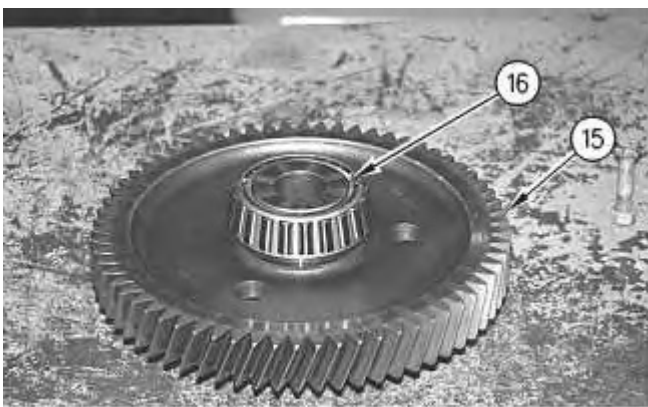

Illustration 38

g01450330

59. Lubricate bearing cones (16) with the oil that is being sealed. Install bearing cones (16) onto idler gear (15).

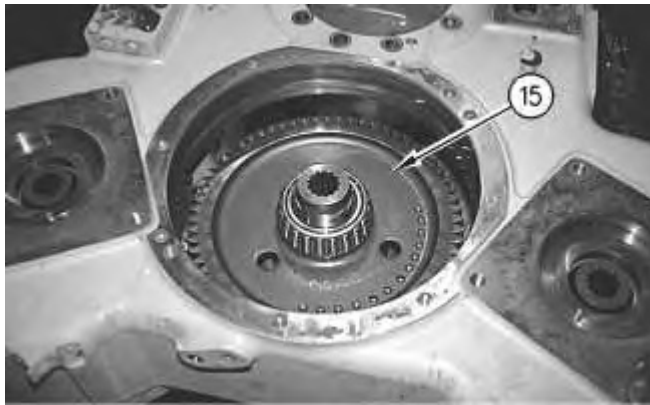

Illustration 39

g01450328

60. Use two people in order to install idler gear (15) and the shim pack. The weight of idler gear (15) is approximately 36 kg (80 lb).



Illustration 40

g01451687

61. Lower the temperature of bearing cup (12). Install bearing cup (12) into pump adapter (5).

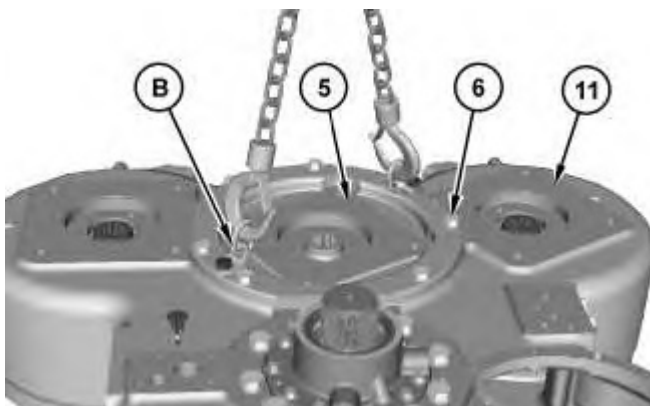

Illustration 41

g01451688

62. Attach Tooling (B) and a suitable lifting device to pump adapter (5). The weight of pump adapter (5) is approximately 50 kg (110 lb). Install pump adapter (5) and bolts (6) onto housing assembly (11).

63. Repeat Steps 48 through 54 in order to adjust bearing end play.

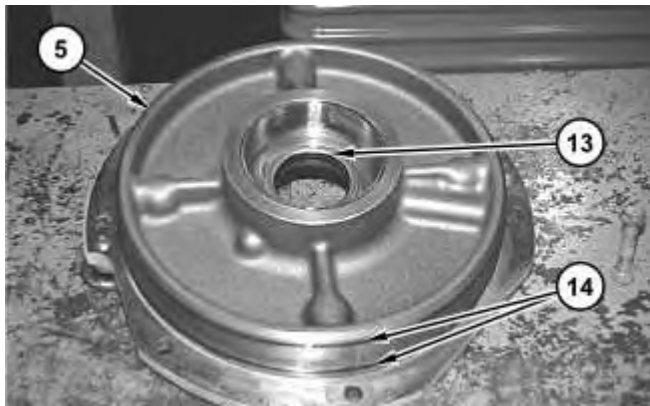

Illustration 42

g01452994

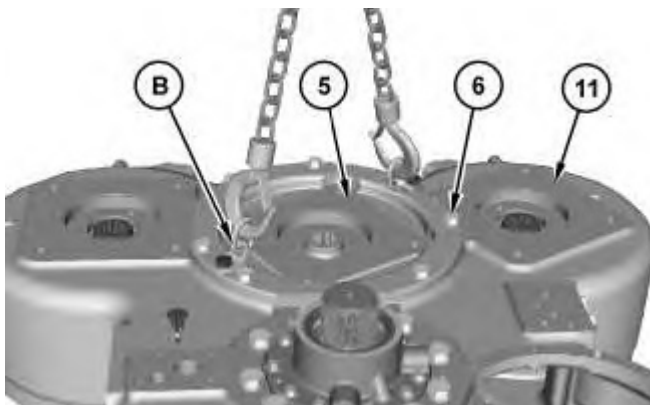

Illustration 43

g01451688

64. Use Tooling (B) and the suitable lifting device in order to remove pump adapter (5) from housing assembly (11).

65. Install lip seal (13) and O-ring seals (14) to pump adapter (5). Use Tooling (B) and the suitable lifting device in order to install pump adapter (5) onto housing assembly (11). Install bolts (6).

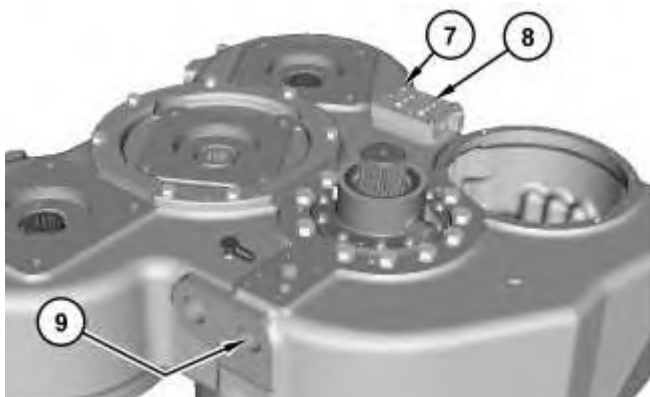

Illustration 44

g01451697

Thank you so much for reading.
Please click the “Buy Now!”
button below to download the
complete manual.



After you pay.

You can download the most
perfect and complete manual in
the world immediately.

Our support email:

ebooklibonline@outlook.com