

Product: WHEEL LOADER

Model: 907K WHEEL LOADER L77

Configuration: 907K Wheel Loader L7700001-UP (MACHINE) POWERED BY C3.3B Engine

Disassembly and Assembly C2.6 and C3.3B Engines for Caterpillar Built Machines

Media Number -UENR0137-11

Publication Date -01/08/2015

Date Updated -12/07/2018

i05242439

Fuel Injection Pump and Governor - Disassemble

SMCS - 1286-015

Disassembly Procedure

Table 1

Required Tools			
Tool	Part Number	Part Description	Qty
A	390-1150	Injection Pump Gear Puller	1
	154-6360	Bolt	1
B	8H-0663	Bearing Puller	1

Start By:

- a. Remove fuel injection pump and governor.

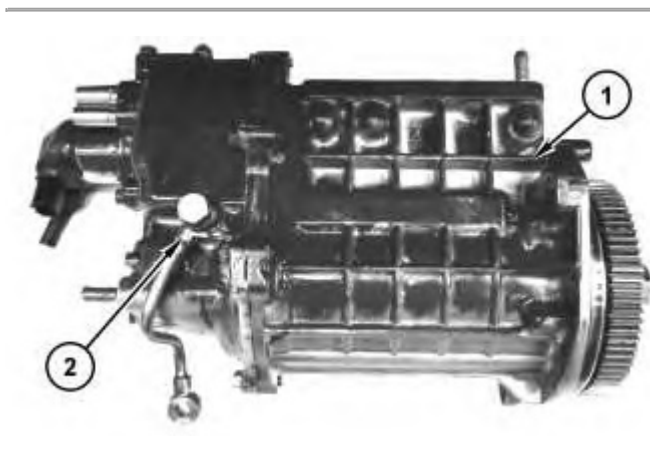

1. Inspect fuel injection pump and governor (1).
2. Remove tube (2).

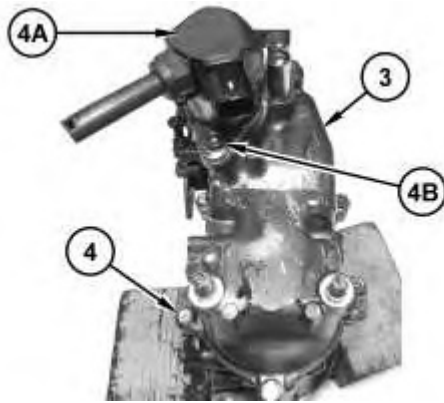

Illustration 2

g02805639

3. Use suitable blocking and position the fuel injection pump and governor. Remove bolts (4) and remove governor housing assembly (3).
4. Remove two bolts (4B) and remove stop solenoid (4A). Replace o-ring if necessary.

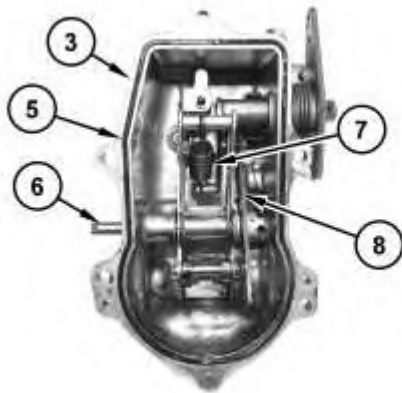

Illustration 3

g02805640

5. Remove and inspect O-ring seal (5) from governor housing assembly (3). If necessary, replace O-ring seal (5) with new.
 6. Remove shaft (6) and spring (7) from governor housing assembly (3). Remove governor lever (8).
-

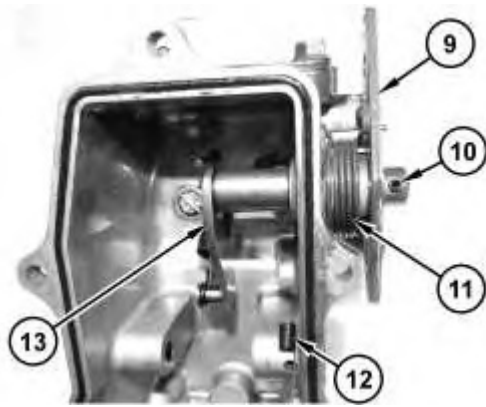

Illustration 4

g02805641

7. Remove pin (10) from governor lever assembly (12).
 8. Remove speed control lever (9) and spring (11) from governor lever assembly (12).
 9. Remove spring (13) and remove governor lever assembly (12) with the O-ring seals.
-

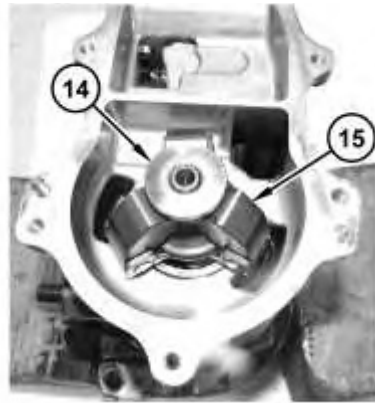

Illustration 5

g02805656

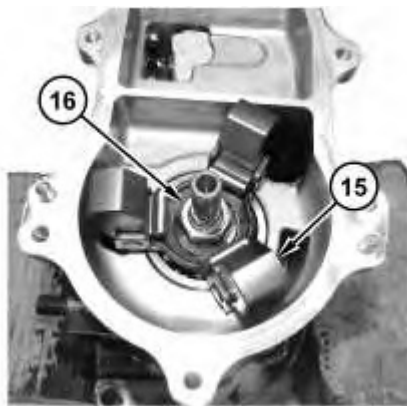

Illustration 6

g02805658

10. Remove governor sleeve (13) and nut (16). Remove governor weights (15).
-



Illustration 7

g02805660

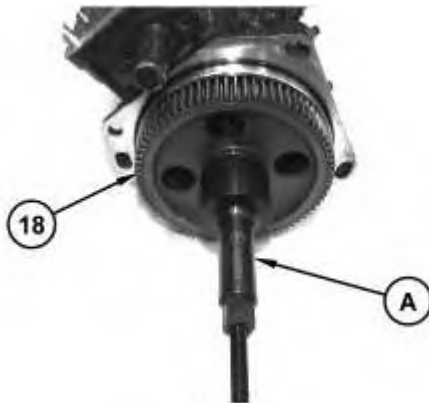

Illustration 8

g02805696

11. Remove nut (17) from gear (18).

Note: Nut (17) has reverse threads.

12. Use Tooling (A) to remove gear (18).

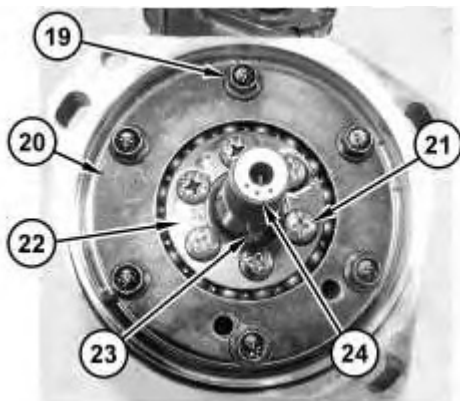

Illustration 9

g02805716

13. Remove bolts (19) and retaining plate (20).

14. Remove fuel camshaft (24) from the housing assembly.

15. Remove screws (21) and retaining plate (22). If necessary, replace key (23) with new.

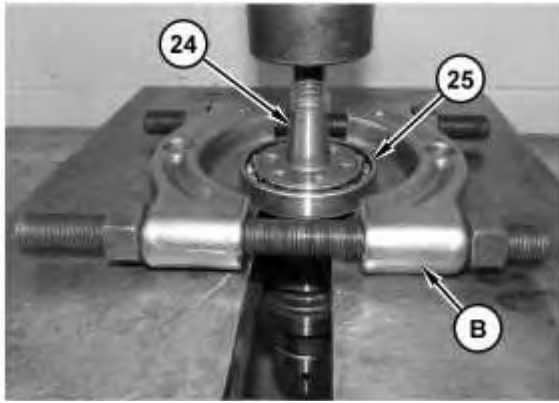

Illustration 10

g02805762

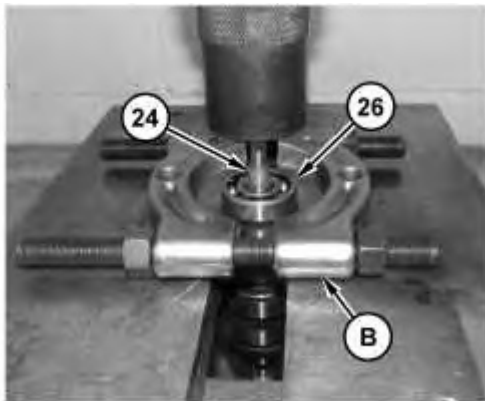

Illustration 11

g02805764

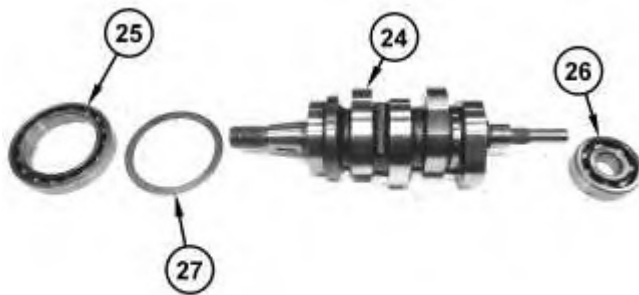

Illustration 12

g02805765

16. Use a suitable press and Tooling (B) to remove bearing (25) from fuel camshaft (24) and ring (27).
17. Use a suitable press and Tooling (B) to remove bearing (26) from fuel camshaft (24).
-

Product: WHEEL LOADER

Model: 907K WHEEL LOADER L77

Configuration: 907K Wheel Loader L7700001-UP (MACHINE) POWERED BY C3.3B Engine

Disassembly and Assembly C2.6 and C3.3B Engines for Caterpillar Built Machines

Media Number -UENR0137-11

Publication Date -01/08/2015

Date Updated -12/07/2018

i05242445

Fuel Injection Pump and Governor - Assemble

SMCS - 1286-016

Assembly Procedure

Table 1

Required Tools			
Tool	Part Number	Part Description	Qty
A	390-1150	Injection Pump Gear Puller	1
	154-6360	Bolt	1
B	8H-0663	Bearing Puller	1

Note: Refer to Specification UENR0995 "Engine Design" for non-specified engine Torque Values.

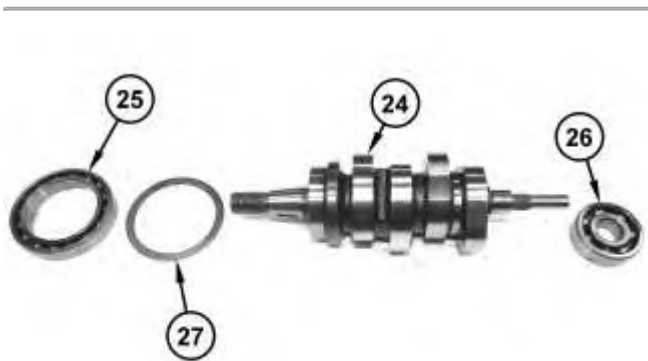

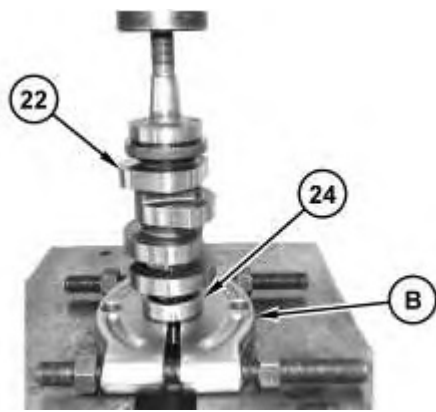

Illustration 2

g02807019

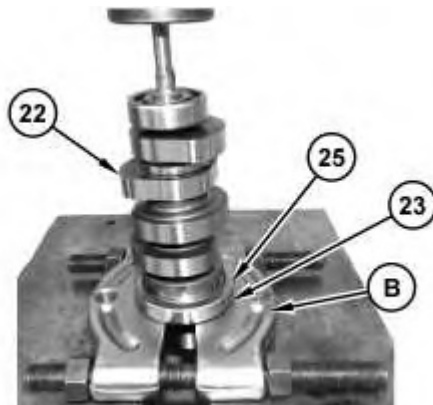

Illustration 3

g02807020

1. Use Tooling (B) and a suitable press to install bearings (26) onto fuel camshaft (24).
 2. Position ring (27). Use Tooling (B) and a suitable press to install bearings (25) onto fuel camshaft (24).
-

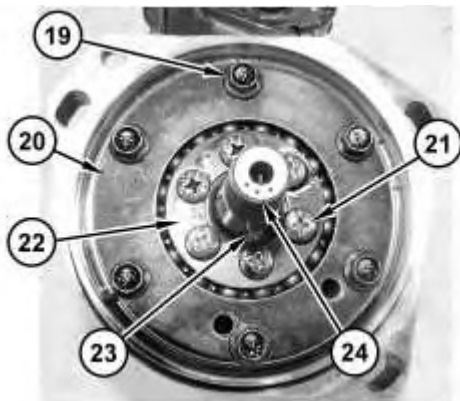

Illustration 4

g02805716

3. If necessary, replace key (23) with new. Position retaining plate (22) and install screws (21). Tighten screws (21) to a torque of 3.9 to 4.2 N·m (34.5 to 37.4 lb in).

4. Position fuel camshaft (24) in the housing assembly.
5. Position retaining plate (20) and install bolts (19). Tighten bolts (19) to a torque of 10 to 11 N·m (87 to 100 lb in).



Illustration 5

g02805660

6. Install gear (18).
7. Install nut (17) to gear (18).
8. For the C3.3B Tighten nut (17) to a torque of 138 to 156 N·m (102 to 115 lb ft).
9. For the C2.6 Tighten nut (17) to a torque of 93 to 102 N·m (69 to 75 lb ft).

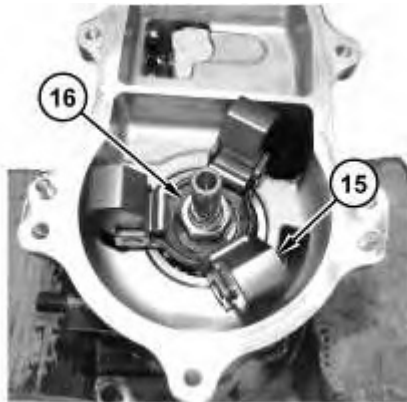

Illustration 6

g02805658

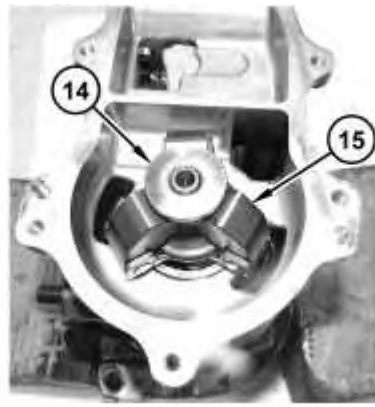

Illustration 7

g02805656

10. Position governor weights (15) and install nut (16). Tighten nut (16) to a torque of 63 to 72 N·m (47 to 53 lb ft). Install governor sleeve (14).

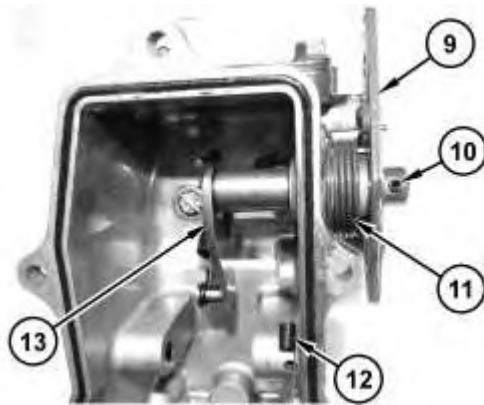
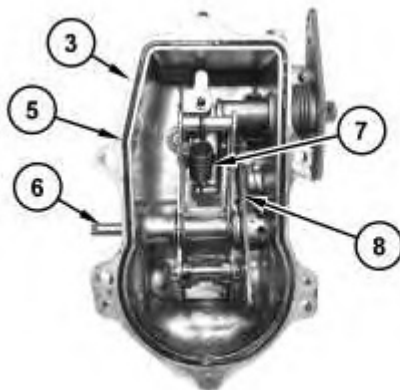

Illustration 8

g02805641

Note: Apply engine oil to all internal parts of governor.

11. Install O-ring seals on governor lever assembly (13). Position governor lever assembly (13) into the governor housing and install spring (12).
12. Install spring (11) and speed control lever (9) on governor lever assembly (13).
13. Install pin (10) into governor lever assembly (13).



14. Position governor lever (8). Install shaft (6) and spring (7) in governor housing assembly (3).
15. If necessary, replace O-ring seal (5) with new. Install O-ring seal (5) in governor housing assembly (3).

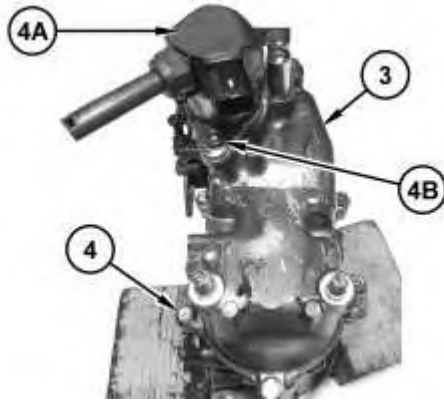

Illustration 10

16. Use a suitable blocking to support the fuel injection pump and governor. Position governor housing assembly (3) and install bolts (4). Tighten bolts (4) to a torque of 10 to 11 N·m (87 to 100 lb in).

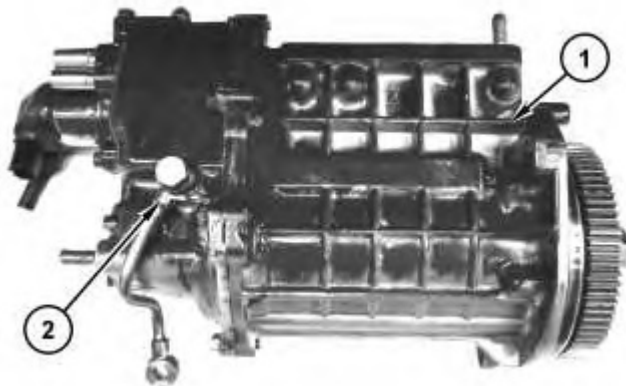

Illustration 11

17. Inspect fuel injection pump and governor (1) for installation.
18. Install tube (2).

End By:

- a. Install fuel injection pump and governor.
-

Product: WHEEL LOADER

Model: 907K WHEEL LOADER L77

Configuration: 907K Wheel Loader L7700001-UP (MACHINE) POWERED BY C3.3B Engine

Disassembly and Assembly C2.6 and C3.3B Engines for Caterpillar Built Machines

Media Number -UENR0137-11

Publication Date -01/08/2015

Date Updated -12/07/2018

i05242446

Fuel Injection Pump and Governor - Install - C3.3B

SMCS - 1286-012

S/N - A9W1-UP

S/N - A9Z1-UP

S/N - AJ71-UP

S/N - CE21-UP

S/N - DML1-UP

S/N - EML1-UP

S/N - F8C1-UP

S/N - FMR1-UP

S/N - FTK1-UP

S/N - GBJ1-UP

S/N - GTK1-UP

S/N - HAM1-UP

S/N - HEL1-UP

S/N - HMR1-UP

S/N - JBE1-UP

S/N - JRD1-UP

S/N - JRF1-UP

S/N - JRS1-UP

S/N - JSL1-UP

S/N - JSN1-UP

S/N - KTS1-UP

S/N - L661-UP

S/N - L771-UP

S/N - L881-UP

S/N - LST1-UP

S/N - MLT1-UP

S/N - MPW1-UP

S/N - NTL1-UP

S/N - PPT1-UP

S/N - RCX1-UP

S/N - SEN1-UP

S/N - STK1-UP

S/N - TAZ1-UP

S/N - TLK1-UP

S/N - WCT1-UP

Installation Procedure

Note: Refer to Specification UENR0995 "Engine Design" for non-specified engine Torque Values.

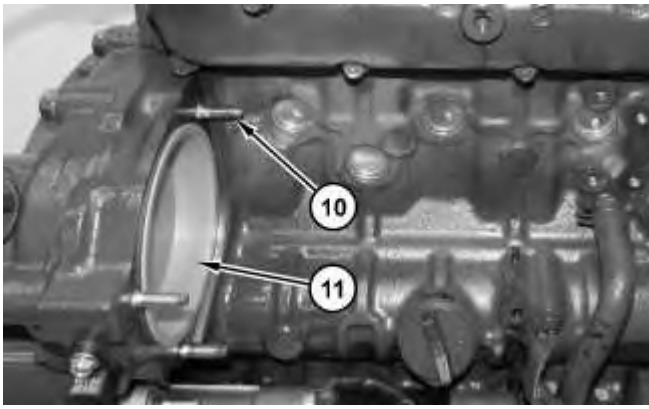

Illustration 1

g03177762

1. If necessary, install studs (10) and remove cover (11).

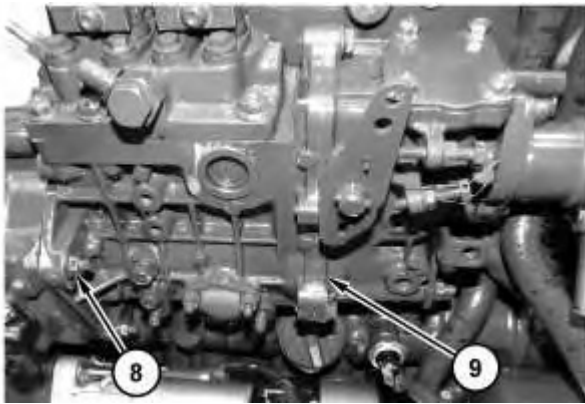

Illustration 2

g03177759

2. Install the O-ring seal on fuel injection pump and governor (9). Position fuel injection pump and governor (9) onto the flywheel housing.
3. Install three nuts (8) to fuel injection pump and governor (9). Tighten nuts (8) to a torque of 18 to 20 N·m (159 ± 177 lb in).

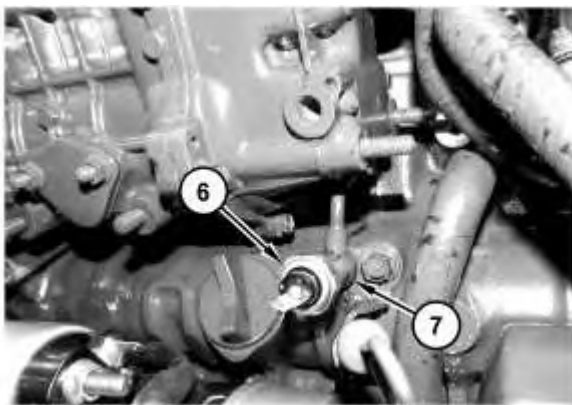

Illustration 3

g03177783

4. Apply engine oil to threads and torque fitting (7) to a torque of 16 to 19 N·m (12 to 14 lb ft).
5. Install engine oil pressure sensor (6) and connect the wiring harness assembly. Tighten the engine oil pressure sensor (6) to a torque of 15 to 19 N·m (11 to 14 lb ft).

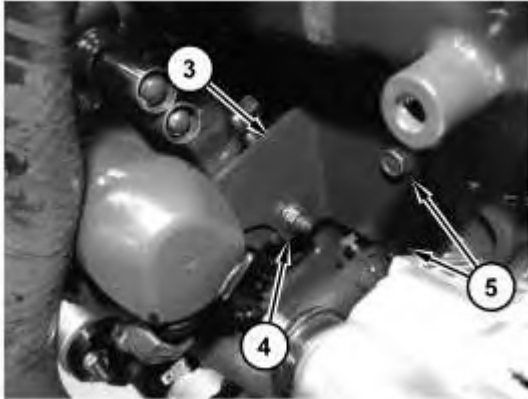

Illustration 4

g02804519

6. Position bracket (3) and install two nuts (4) and two bolts (5).



Illustration 5

g02804516

7. Check the timing marks and install the O-ring seal and oil plug cap (1). Install the O-ring seal and cover (2) on flywheel housing (3).

End By:

- a. Install the fuel injection lines.
-

Product: WHEEL LOADER

Model: 907K WHEEL LOADER L77

Configuration: 907K Wheel Loader L7700001-UP (MACHINE) POWERED BY C3.3B Engine

Disassembly and Assembly C2.6 and C3.3B Engines for Caterpillar Built Machines

Media Number -UENR0137-11

Publication Date -01/08/2015

Date Updated -12/07/2018

i05242455

Fuel Injection Pump - Remove and Install

SMCS - 1251-010

Removal Procedure

Table 1

Required Tools			
Tool	Part Number	Part Description	Qty
A	390-1150	Injection Pump Gear Puller	1

Start By:

- a. Remove fuel injection line.

Note: Refer to Specification UENR0995 "Engine Design" for non-specified engine Torque Values.

1. Turn the fuel supply to the OFF position.
2. Turn the battery disconnect switch to the OFF position.

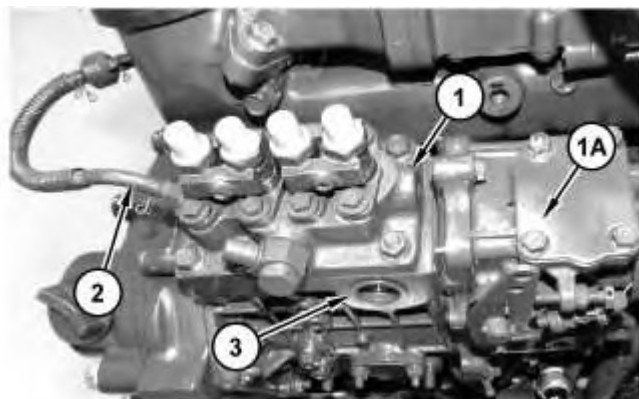

3. Disconnect hose assembly (2) from fuel injection pump (1).
4. Remove sight cover (3) from fuel injection pump (1).

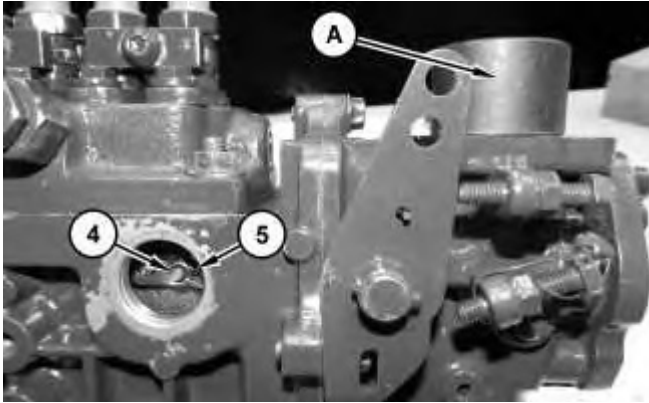

Illustration 2

5. Remove the shutoff solenoid and cover (1A). Install Tooling (A) to hold back the governor control arm and assist removing the spring (5) and nut (4).

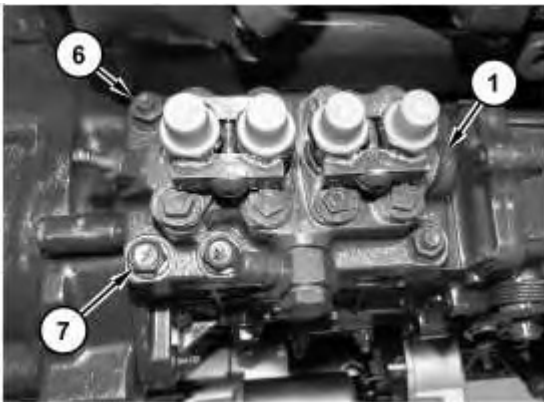

Illustration 3

6. Disconnect spring (5) and attach a thin wire (6) to spring (5). Remove nut (4). Position the lever (7) off the stud.



Personal injury can result from parts and/or covers under spring pressure.

Spring force will be released when covers are removed.

Be prepared to hold spring loaded covers as the bolts are loosened.

7. Remove two nuts (6) and four bolts (7) from fuel injection pump (1). The fuel injection pump (1) is spring loaded.
8. Carefully remove fuel injection pump (1) from the fuel injection pump housing.

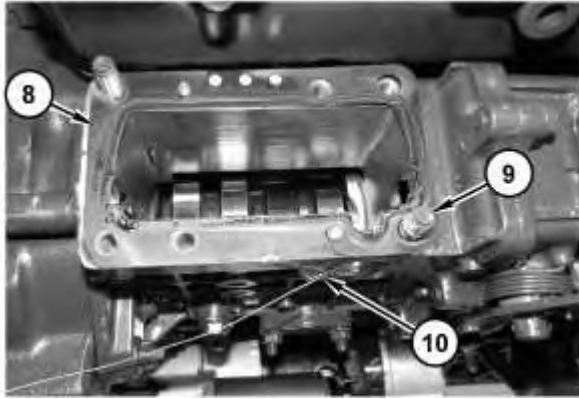

Illustration 4

g02781040

9. Remove gasket shims (8).
10. If necessary, remove studs (9) from the fuel injection pump housing.
11. To secure the spring from falling inside the housing use wire (10).
12. Clean fuel injection pump (1) and the area around the fuel injection pump. Ensure that the area is free from contamination before beginning installation.

Installation Procedure

NOTICE

Refer to System Operation, Testing and Adjusting, "Cleanliness of Fuel System Components" for detailed information on the standards of cleanliness that must be observed during ALL work on the fuel system.

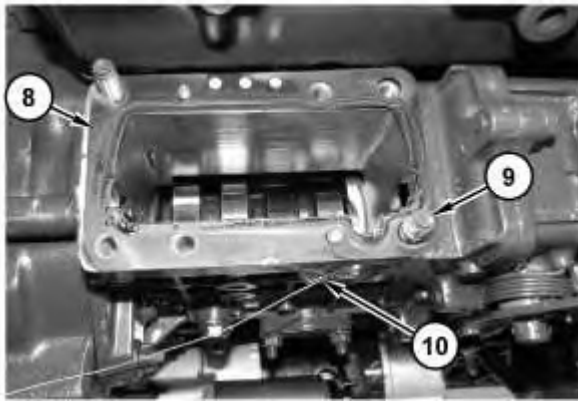

Illustration 5

g02781040

1. Keep wire (10) secure to the spring to prevent falling into the housing.
2. If necessary, install studs (9) into the fuel injection pump housing.
3. Position new gasket shims (8) onto the fuel injection pump housing.

Note: When you disassemble or replace, make sure that you use the same number of new gasket shims with the same thickness.

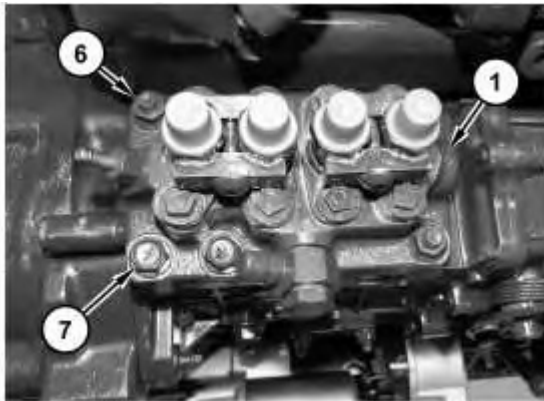

Illustration 6

g02781105

4. Carefully install fuel injection pump (1) into the fuel injection pump housing .
 5. Install four new bolts (7) into fuel injection pump (1). Install two nuts (6) into fuel injection pump (1). Tighten bolts (7) to a torque of 24 to 27 N·m (214 to 240 lb in). Tighten nuts (6) to a torque of 18 to 20 N·m (159 to 178 lb in).
-



Illustration 7

g02781722

6. Position the lever on the stud. Install nut (4) to hold the lever in place. Tighten nut (4) to a torque of 3 to 4 N·m (26 to 36 lb in).
7. Connect spring (5) with the thin wire.

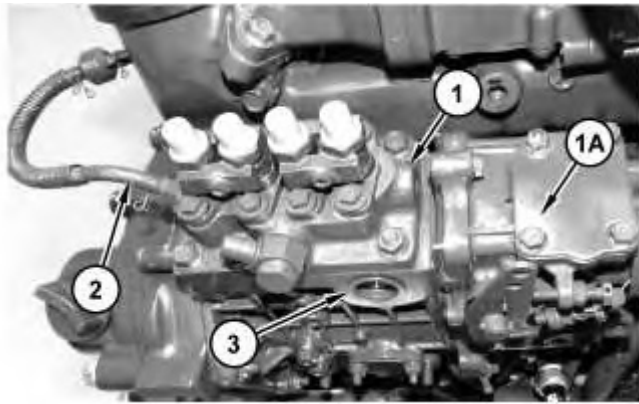

Illustration 8

g02781037

8. Install sight cover (3).
9. Connect hose assembly (2) to fuel injection pump (1).
10. Turn the fuel supply to the ON position.
11. Turn the battery disconnect switch to the ON position.
12. After replacement of the fuel injection pump, the fuel injection pump must be calibrated. Refer to System Operation, Testing and Adjusting, "Fuel Injection Timing - Check".

End By:

- a. Install fuel injection lines.

Thank you so much for reading.
Please click the “Buy Now!”
button below to download the
complete manual.



After you pay.

You can download the most
perfect and complete manual in
the world immediately.

Our support email:

ebooklibonline@outlook.com