

Product: COMPACTOR

Model: CB-34B XW COMPACTOR 472

Configuration: CB34B XW Compactor 47200001-UP (MACHINE) POWERED BY C2.2 Engine

## **Disassembly and Assembly C1.1, C1.5 and C2.2 Engines for Caterpillar Built Machines**

Media Number -KENR6948-06

Publication Date -01/06/2015

Date Updated -02/08/2018

i02602632

# **Engine Oil Pump - Remove**

SMCS - 1304-011

## **Removal Procedure**

### **Start By:**

- a. Remove the front housing. Refer to Disassembly and Assembly, "Housing (Front) - Remove".

---

### **NOTICE**

**Care must be taken to ensure that fluids are contained during performance of inspection, maintenance, testing, adjusting and repair of the product. Be prepared to collect the fluid with suitable containers before opening any compartment or disassembling any component containing fluids.**

**Dispose of all fluids according to local regulations and mandates.**

---

### **NOTICE**

**Keep all parts clean from contaminants.**

**Contaminants may cause rapid wear and shortened component life.**

---

---

## NOTICE

If the front housing is not installed, do not turn the crankshaft.  
Damage to the engine may occur.

---

### Engine Oil Pump

---

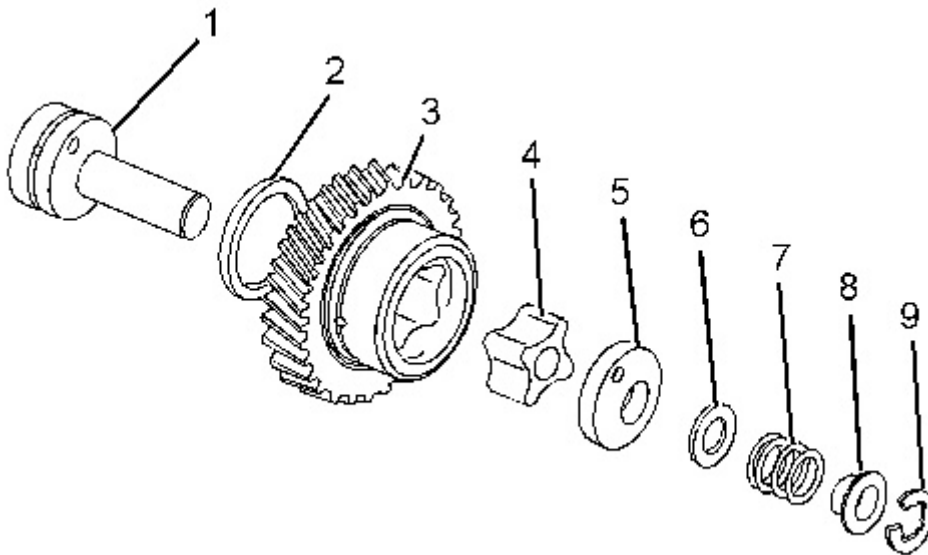

Illustration 1

g01304840

### **WARNING**

**Personal injury can result from being struck by parts propelled by a released spring force.**

**Make sure to wear all necessary protective equipment.**

**Follow the recommended procedure and use all recommended tooling to release the spring force.**

---

1. Remove C-clip (9) that retains idler gear (3) on idler hub (1).
2. Remove the following items from idler hub (1):
  - Collar (8)
  - Spring (7)

- Shim (6)
  - Oil pump cover (5)
3. Remove idler gear (3) from idler hub (1).
  4. Remove inner rotor (4) from idler hub (1).
  5. Remove thrust washer (2) from idler hub (1).
  6. In order to remove the suction pipe, follow Steps 6.a through 6.d .

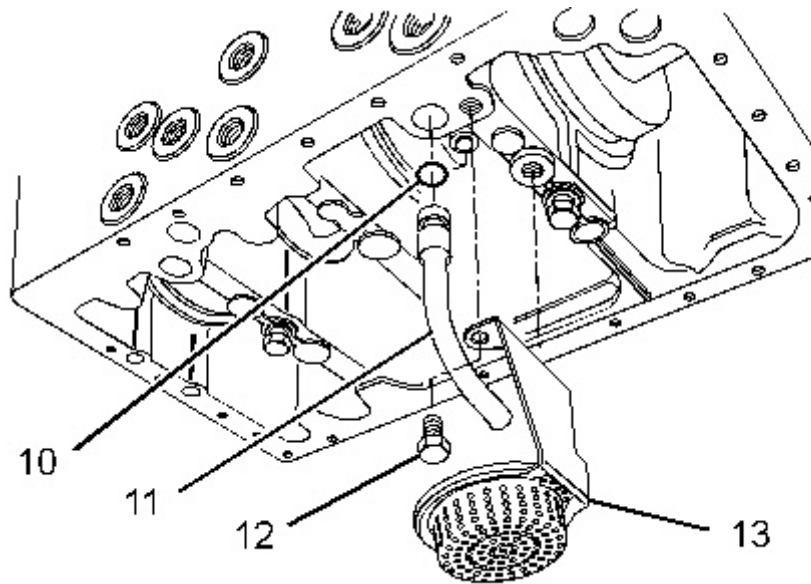

---

Illustration 2

g01327023

- a. Remove the engine oil pan. Refer to Disassembly and Assembly, "Engine Oil Pan - Remove and Install".
- b. Remove bolts (12) and oil strainer (13) from the cylinder block. Inspect the oil strainer for damage. If the oil strainer is damaged, use a new part for replacement.
- c. Remove suction pipe (11) from the cylinder block.
- d. Remove O-ring seal (10) from the suction pipe.

## Idler Hub

---

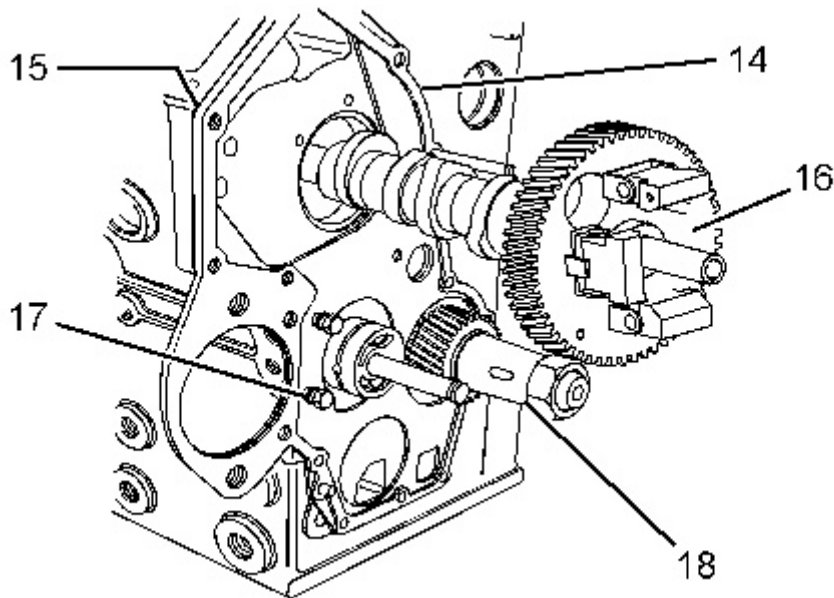

Illustration 3  
Typical example

g01320621

1. Remove camshaft (16). Refer to Disassembly and Assembly, "Camshaft - Remove".
2. Remove bolts (17) and plate (14) from the cylinder block. Remove joint (15).
3. Remove crankshaft (18). Refer to Disassembly and Assembly, "Crankshaft - Remove".

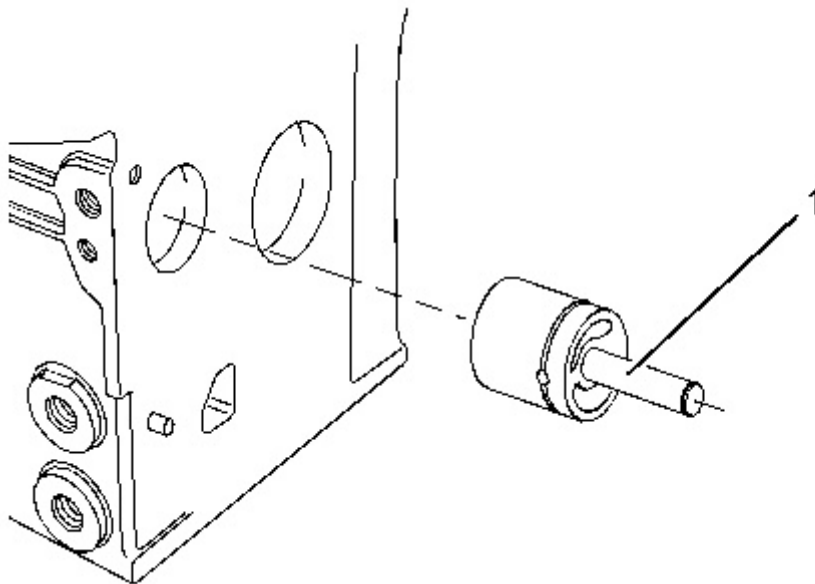

Illustration 4  
Typical example

g01311490

4. Use a hammer and use a suitable drift to remove idler hub (1) from the cylinder block. Align the drift to the rear face of the hub and drive the hub from the inside of the cylinder block outward.

Product: COMPACTOR

Model: CB-34B XW COMPACTOR 472

Configuration: CB34B XW Compactor 47200001-UP (MACHINE) POWERED BY C2.2 Engine

## Disassembly and Assembly C1.1, C1.5 and C2.2 Engines for Caterpillar Built Machines

Media Number -KENR6948-06

Publication Date -01/06/2015

Date Updated -02/08/2018

i07360149

# Engine Oil Pump - Install

SMCS - 1304-012

## Installation Procedure

Table 1

Required Tools			
Tool	Part Number	Part Description	Qty
A <sup>(1)</sup>	256-4864	Alignment Tool	1
A <sup>(2)</sup>	301-0285	Alignment Tool	1

<sup>(1)</sup> C1.1 engine

<sup>(2)</sup> C1.5 and C2.2 engines

---

### NOTICE

**Keep all parts clean from contaminants.**

**Contaminants may cause rapid wear and shortened component life.**

---

### NOTICE

**If the front housing is not installed, do not turn the crankshaft.  
Damage to the engine may occur.**

---

## Idler Hub

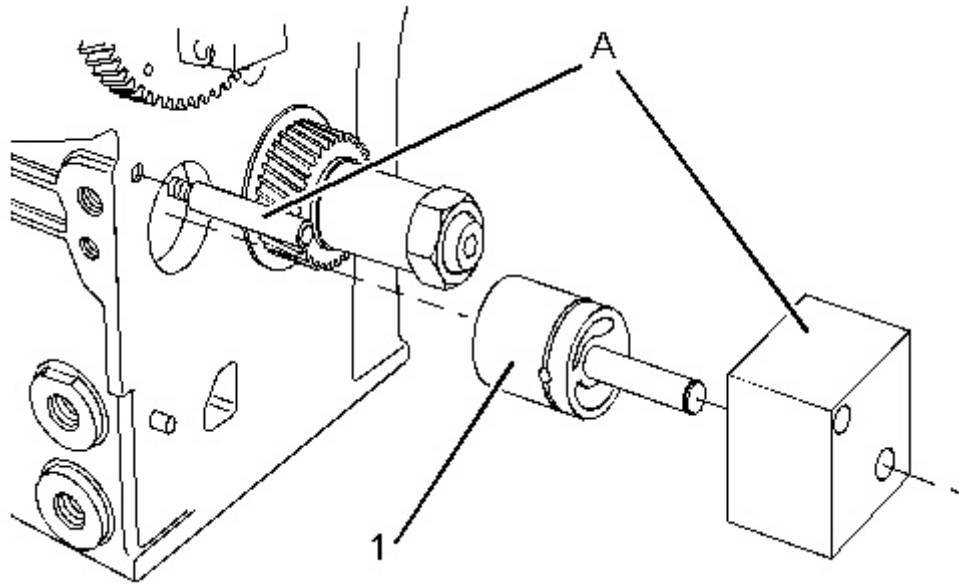
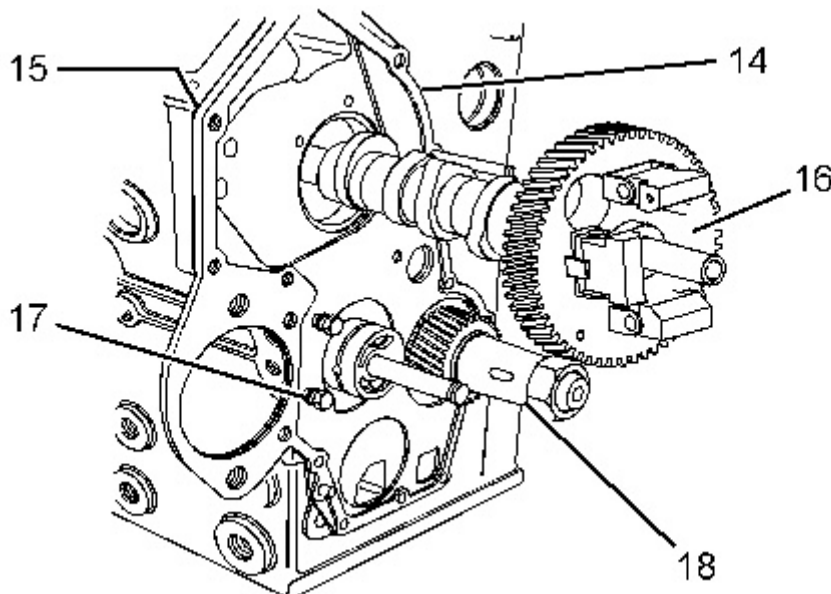

Illustration 1

g01305803

Typical example

1. Install the pin of Tooling (A) to the cylinder block.
2. Install idler hub (1) into the guide plate of Tooling (A). Align the guide plate of Tooling (A) with pin of Tooling (A).
3. Use a hammer to strike the guide plate of Tooling (A). Drive idler hub (1) into the cylinder block until the guide plate contacts the front of the cylinder block.
4. Remove Tooling (A).



5. Install crankshaft (18). Refer to Disassembly and Assembly, "Crankshaft - Install".
6. Position a new joint (15) on the cylinder block. Align plate (14) with the dowels in the cylinder block and install the plate. Install bolts (17) and tighten to a torque of 10 N·m (89 lb in).
7. Install camshaft (18). Refer to Disassembly and Assembly, "Camshaft - Install".

## Engine Oil Pump

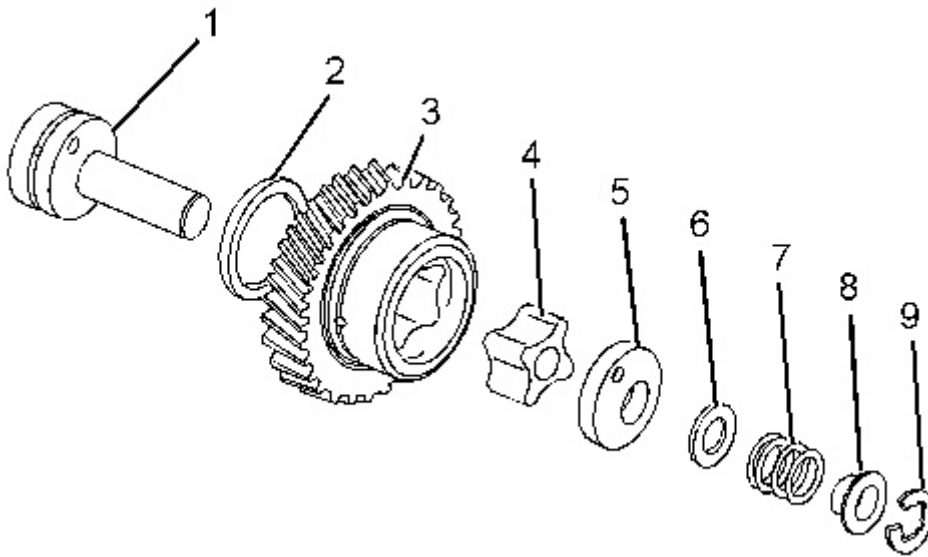

Illustration 3

g01304840

Typical example

1. Install thrust washer (2). Lubricate the thrust washer with clean engine oil.
-

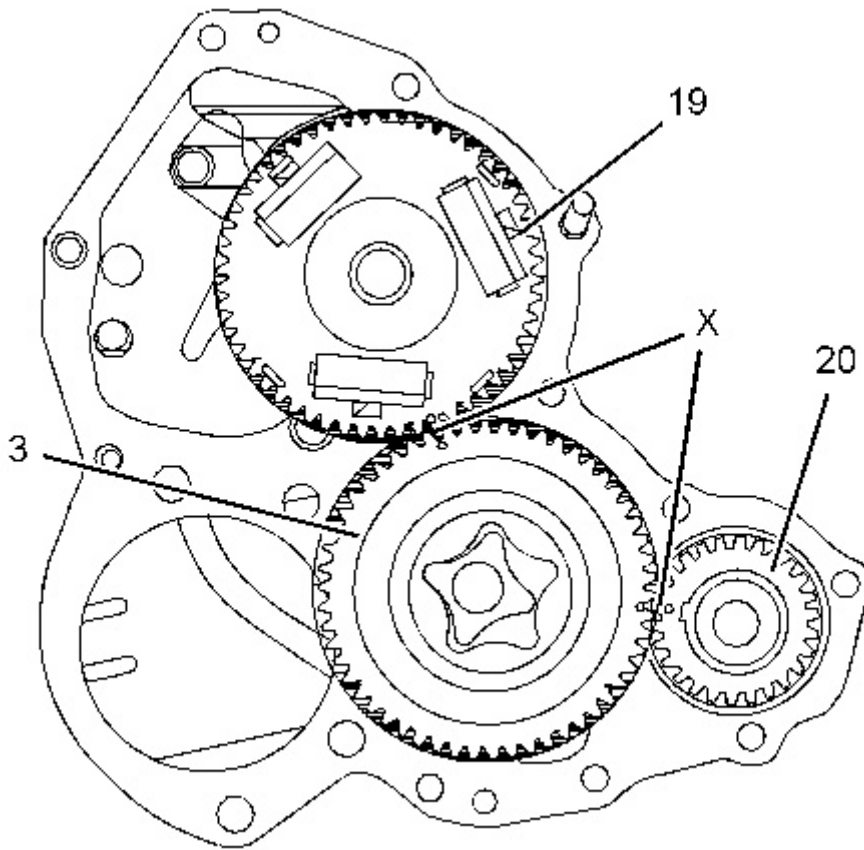

Illustration 4  
Typical example

g01305805

**! WARNING**

**Improper assembly of parts that are spring loaded can cause bodily injury.**

**To prevent possible injury, follow the established assembly procedure and wear protective equipment.**

2. Apply clean engine oil to the faces of inner rotor (4) and to the vanes of idler gear (3).
3. Align timing marks (X) on idler gear (3) with the respective timing marks on gears (19) and (20). Install idler gear (3) onto idler hub (1).
4. Install inner rotor (4) to idler gear (3).

**! WARNING**

**Personal injury can result from the release of the spring force.**



**The drive shaft, the piston, and the drive gear are under spring force.**

**Use a press to slowly release the spring force before the components are removed.**

---

5. Install the following items to idler hub (1):

- Oil pump cover (5)
- Shim (6)
- Spring (7)
- Collar (8)

Refer to Illustration 3.

6. Install retaining ring (9) on idler hub (1).

---

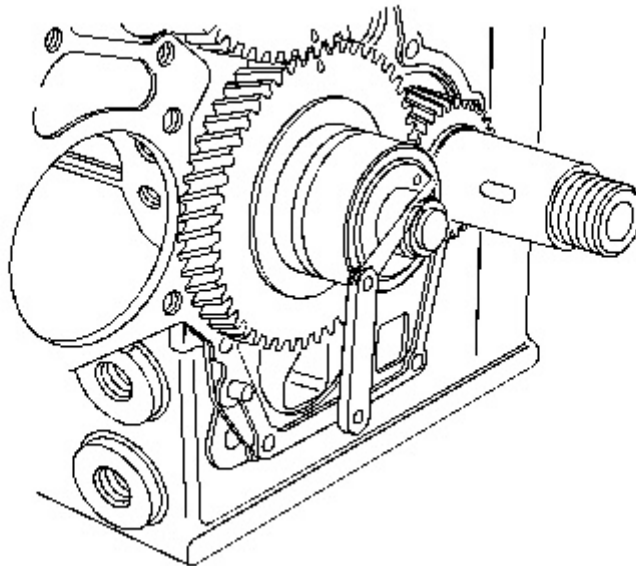

---

Illustration 5

g01320625

Checking end play by using a feeler gauge

7. Use a feeler gauge to measure the end play of the engine oil pump. Refer to Specifications, "Engine Oil Pump".
  8. If the oil strainer was removed, follow Steps 8.a through 8.c to install the oil strainer.
-

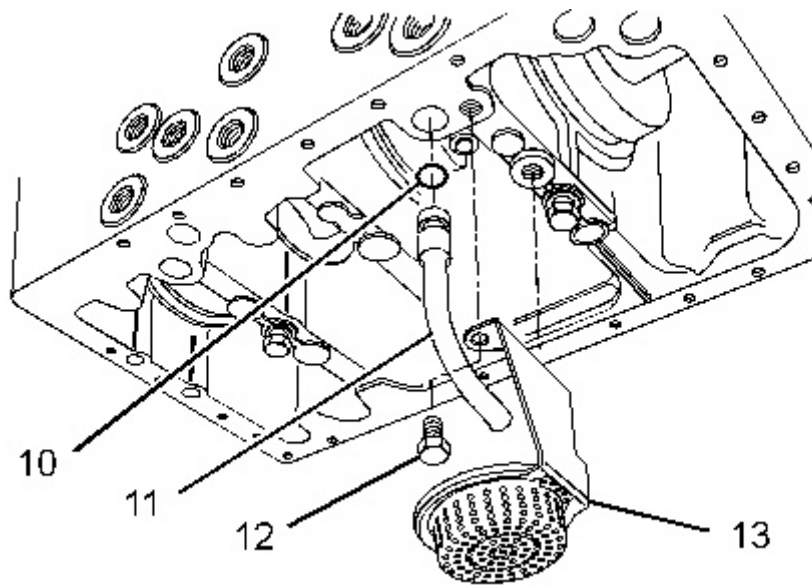

---

Illustration 6

g01327023

- a. Install a new O-ring seal (10) on oil tube assembly (11).
- b. Install oil suction pipe (11) in the cylinder block.
- c. Install oil strainer (13) to the cylinder block and tighten bolts (12) to a torque of 11 N·m (97 lb in).

**End By:**

- a. Install the front housing. Refer to Disassembly and Assembly, "Housing (Front) - Install".
  - b. Install the engine oil pan. Refer to Disassembly and Assembly, "Engine Oil Pan - Remove and Install".
-

Product: COMPACTOR

Model: CB-34B XW COMPACTOR 472

Configuration: CB34B XW Compactor 47200001-UP (MACHINE) POWERED BY C2.2 Engine

## **Disassembly and Assembly C1.1, C1.5 and C2.2 Engines for Caterpillar Built Machines**

Media Number -KENR6948-06

Publication Date -01/06/2015

Date Updated -02/08/2018

i07360814

# **Water Pump - Remove and Install - C1.5 and C2.2 Engines**

SMCS - 1361-012; 1361-011

S/N - CMY1-UP

S/N - CYP1-UP

S/N - CYS1-UP

## **Removal Procedure**

### **Start By:**

- a. Remove the fan. Refer to Disassembly and Assembly, "Fan - Remove and Install" for the correct procedure.
- b. If necessary, remove the alternator. Refer to Disassembly and Assembly, "Alternator - Remove and Install" for the correct procedure.

---

### **NOTICE**

**Keep all parts clean from contaminants.**

**Contaminants may cause rapid wear and shortened component life.**

---

---

### **NOTICE**

**Care must be taken to ensure that fluids are contained during performance of inspection, maintenance, testing, adjusting and repair of the product. Be prepared to collect the fluid with suitable containers**

**before opening any compartment or disassembling any component containing fluids.**

**Dispose of all fluids according to local regulations and mandates.**

---

1. Drain the coolant from the cooling system into a suitable container for storage or disposal. Refer to Operation and Maintenance Manual, "Cooling System Coolant - Drain" for more information.
- 

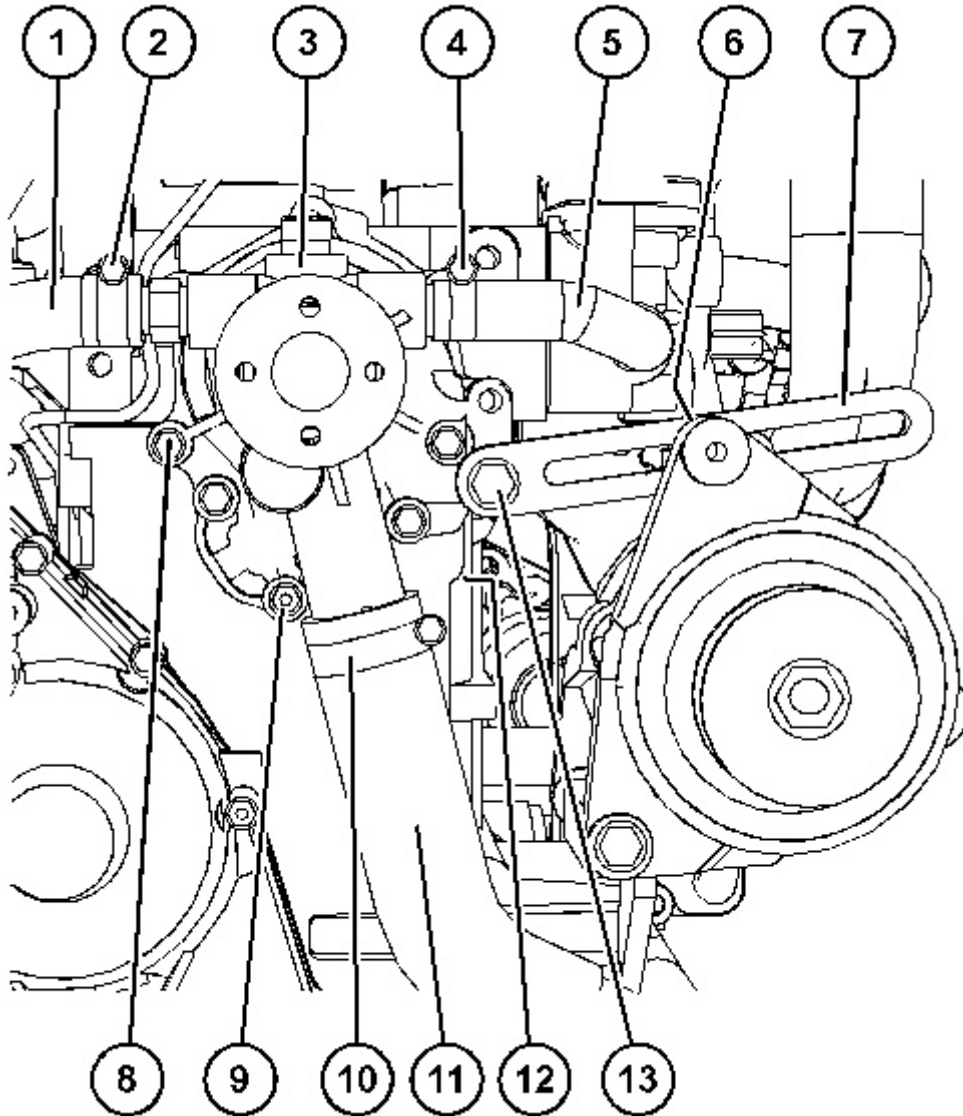

---

Illustration 1  
Typical example

g06215571

2. Loosen hose clamp (10) and disconnect hose (11) from water pump (3).
3. Loosen hose clamp (2) and disconnect hose (1) from water pump (3).

4. Loosen hose clamps (4) and disconnect hose (5) from water pump (3) and the thermostat housing
5. Remove bolt (13) for alternator bracket (7). Position the alternator bracket away from water pump (3).

**Note:** The alternator bracket on some engines is secured by two bolts.

6. Remove bolts (8) and nut (9) from water pump (1). Remove the water pump from the cylinder block.

**Note:** If necessary, gently tap the water pump with a soft faced hammer to loosen the water pump.

7. Remove gasket (12) (not shown).

## Installation Procedure

Table 1

Required Tools			
Tool	Part Number	Part Description	Qty
A	-	Loctite 242	1

---

### NOTICE

**Keep all parts clean from contaminants.**

**Contaminants may cause rapid wear and shortened component life.**

---

1. Ensure that the gasket surfaces of the water pump and the cylinder block are clean and free from damage.
-

TOP

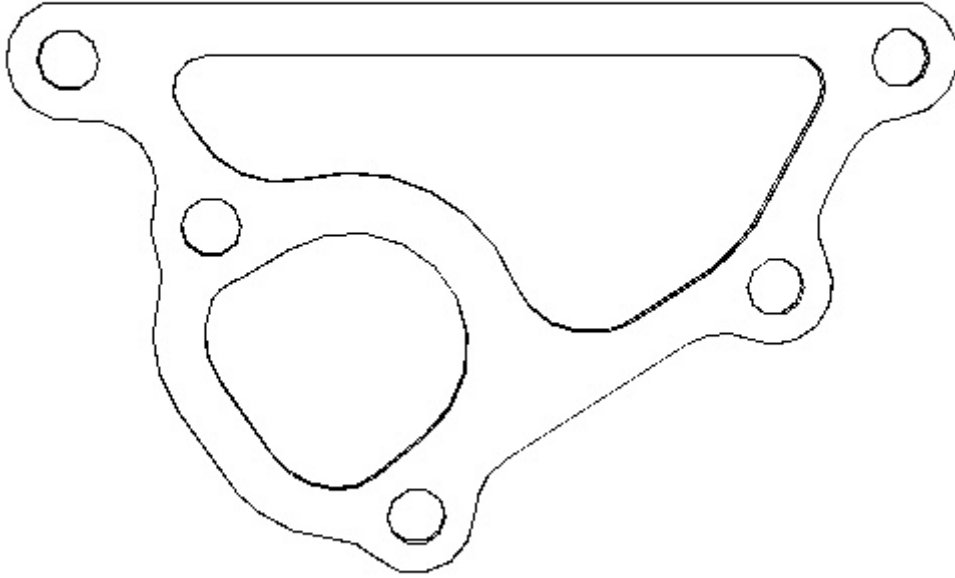

---

Illustration 2

g06217509

Correct orientation of the water pump to block gasket

---

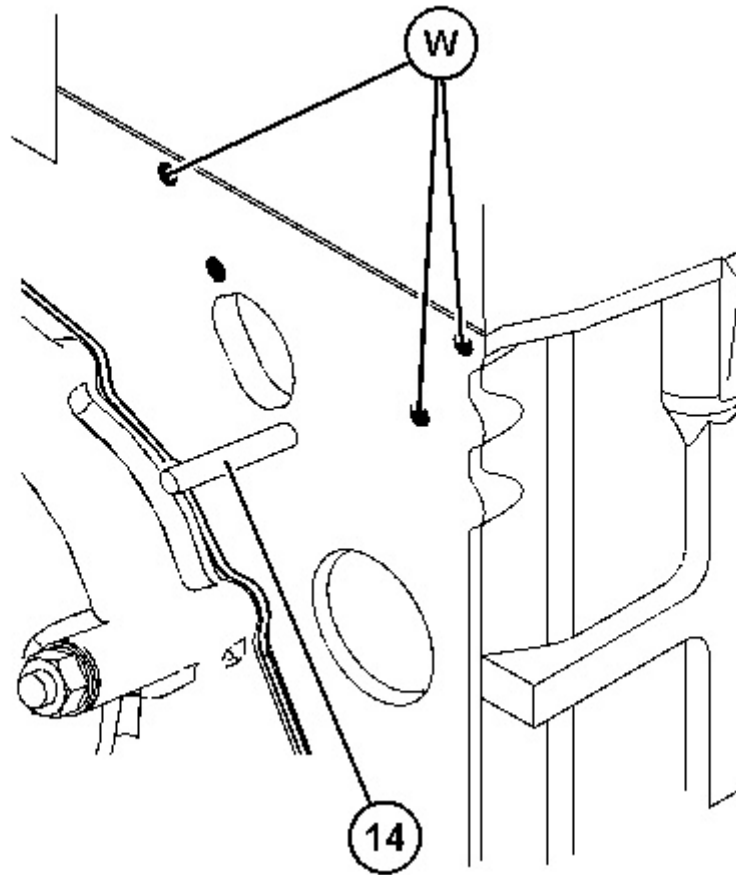

---

Illustration 3  
Typical example

g06218256

2. Ensure that the bolt holes in Position (W) and stud (14) are clean and free from oil and coolant.
  3. Install a new gasket (12) (not shown) over stud (14). Ensure that the gasket is correctly oriented. Refer to Illustration 2.
-

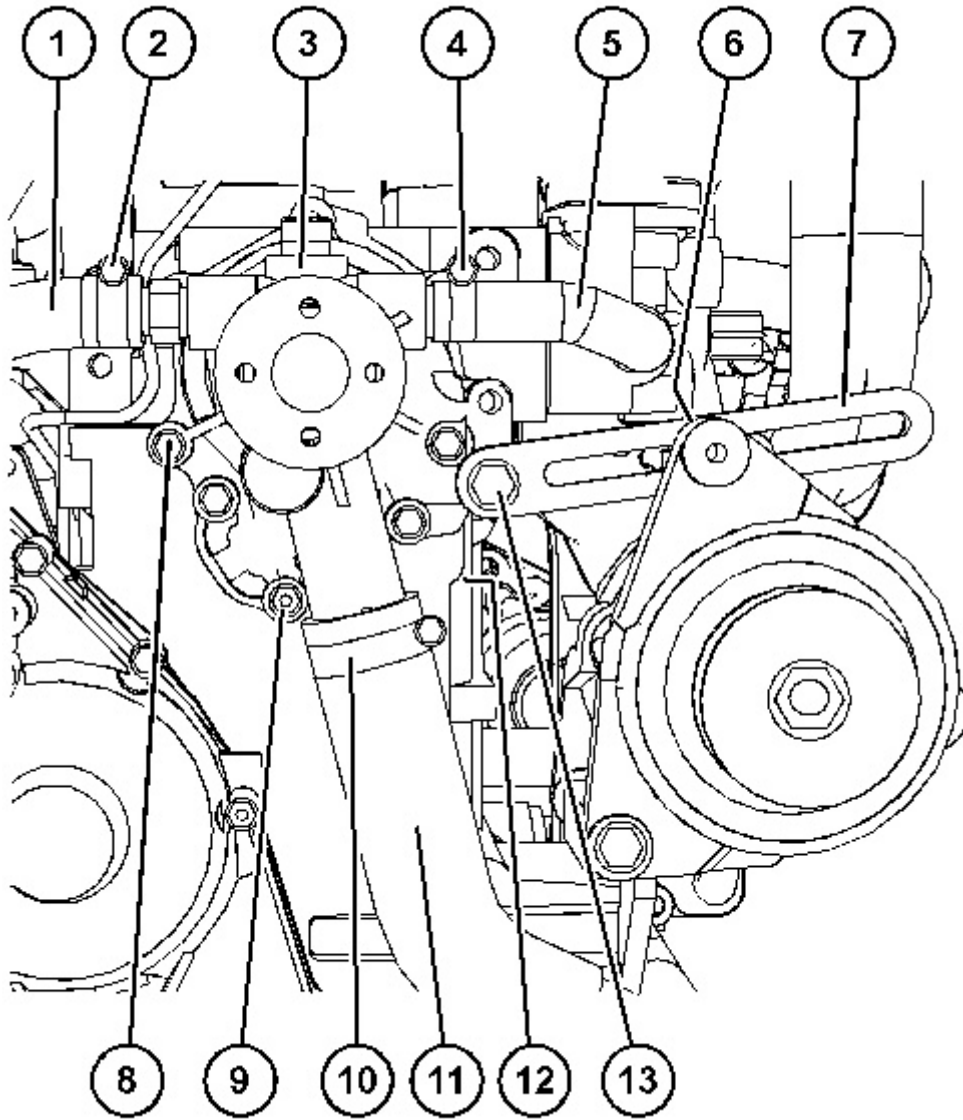

---

Illustration 4  
Typical example

---

g06215571



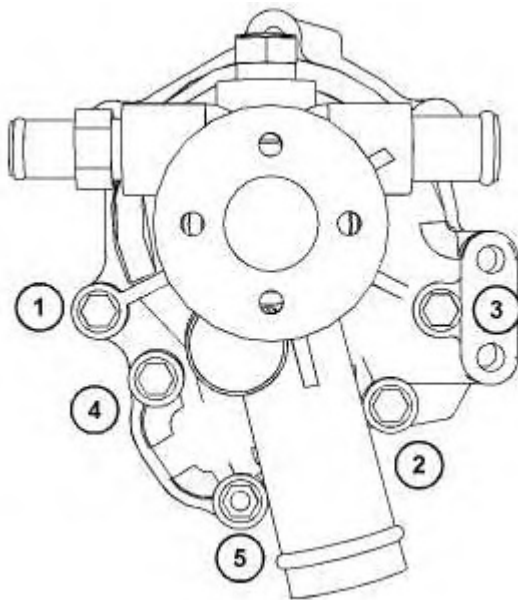

Illustration 5

g06215627

Water pump bolts and nut tightening sequence

4. Apply Tooling (A) to the first two threads of bolts (8) and nut (9).
5. Install water pump (3).
6. Install bolts (8) and nut (9) hand tight. Ensure that gasket (12) (not shown) is correctly positioned.
7. Tighten bolts (8) and nut (9) to a torque of 5 N·m (44 lb in) in the sequence shown in Illustration 5.
8. Tighten bolts (8) and nut (9) to a torque of 10 N·m (89 lb in) in the sequence shown in Illustration 5.
9. Connect hose (1) to water pump (3). Securely tighten hose clamp (2).
10. Connect hose (5) to water pump (3). Securely tighten hose clamp (4).
11. Connect hose (11) to water pump (3). Securely tighten hose clamp (10).
12. Position alternator bracket (7) onto water pump (3). Loosely install bolt (13) to the alternator bracket.

**Note:** The alternator bracket on some engines is secured by two bolts.

13. Fill the cooling system with coolant. Refer to Operation and Maintenance Manual, "Cooling System Coolant - Fill" for the correct procedure.

**End By:**

- a. If necessary, install the alternator. Refer to Disassembly and Assembly, "Alternator - Remove and Install" for the correct procedure.

- b. Install the fan. Refer to Disassembly and Assembly, "Fan - Remove and Install" for the correct procedure.
-

Product: COMPACTOR

Model: CB-34B XW COMPACTOR 472

Configuration: CB34B XW Compactor 47200001-UP (MACHINE) POWERED BY C2.2 Engine

## **Disassembly and Assembly**

### **C1.1, C1.5 and C2.2 Engines for Caterpillar Built Machines**

Media Number -KENR6948-06

Publication Date -01/06/2015

Date Updated -02/08/2018

i02602667

# **Water Temperature Regulator Housing - Remove and Install**

SMCS - 1393-010

## **Removal Procedure**

---

### **NOTICE**

**Keep all parts clean from contaminants.**

**Contaminants may cause rapid wear and shortened component life.**

---

---

### **NOTICE**

**Care must be taken to ensure that fluids are contained during performance of inspection, maintenance, testing, adjusting and repair of the product. Be prepared to collect the fluid with suitable containers before opening any compartment or disassembling any component containing fluids.**

**Dispose of all fluids according to local regulations and mandates.**

---

1. Drain the coolant from the cooling system into a suitable container for storage or disposal. Refer to Operation and Maintenance Manual, "Cooling System Coolant - Drain" for more information.
-

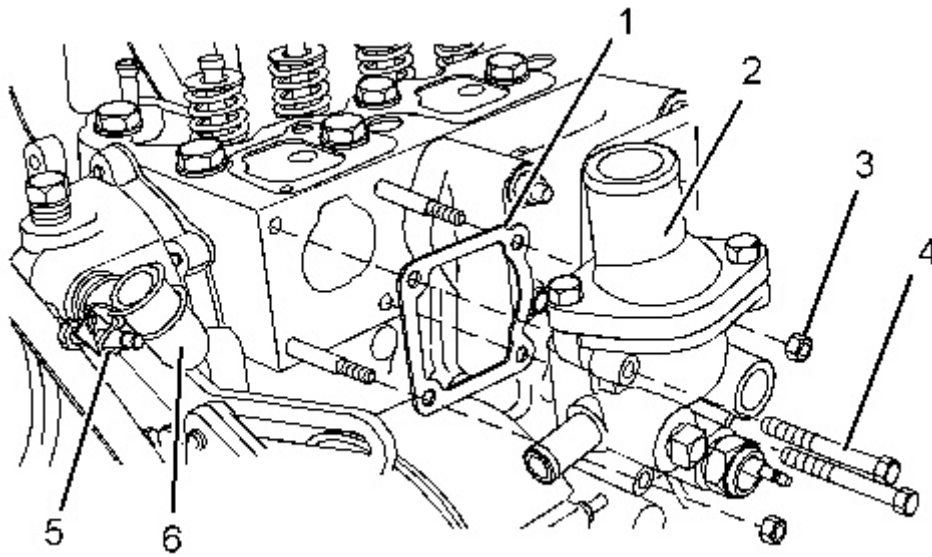

---

Illustration 1

g01307377

Typical example

2. Loosen hose clamps (5) and disconnect hose (6) from water temperature regulator housing (2).
3. Remove bolts (4) and nuts (3).
4. Remove water temperature regulator housing (2) from the cylinder head.
5. Remove joint (1) from the cylinder head.
6. If necessary, remove the water temperature regulator. Refer to Disassembly and Assembly , " Water Temperature Regulator - Remove and Install".

## Installation Procedure

---

### NOTICE

**Keep all parts clean from contaminants.**

**Contaminants may cause rapid wear and shortened component life.**

---

1. Ensure that the mating surfaces of the cylinder head and the water temperature regulator housing are clean and free from damage.
-

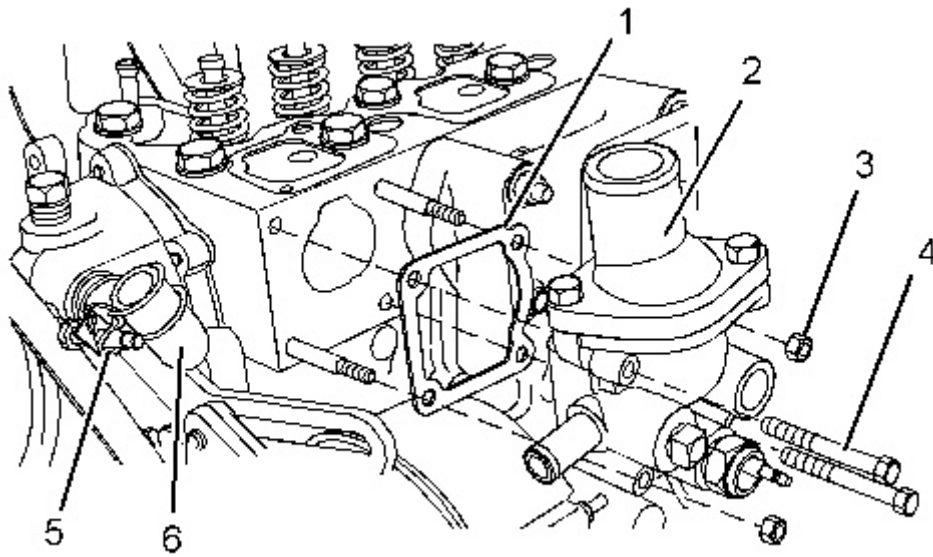

---

Illustration 2  
Typical example

g01307377

2. Install a new joint (1) to the cylinder head.
  3. Install water temperature regulator housing (2) to the cylinder head.
  4. Install bolts (4) and nuts (3). Tighten the fasteners to a torque of 10 N·m (89 lb in).
  5. Connect hose (6) to water temperature regulator housing (2). Tighten hose clamps (5).
  6. If necessary, install the water temperature regulator. Refer to Disassembly and Assembly , " Water Temperature Regulator - Remove and Install".
  7. Fill the cooling system with coolant. Refer to Operation and Maintenance Manual, "Cooling System Coolant - Fill" for the correct procedure.
-

Product: COMPACTOR

Model: CB-34B XW COMPACTOR 472

Configuration: CB34B XW Compactor 47200001-UP (MACHINE) POWERED BY C2.2 Engine

## **Disassembly and Assembly C1.1, C1.5 and C2.2 Engines for Caterpillar Built Machines**

Media Number -KENR6948-06

Publication Date -01/06/2015

Date Updated -02/08/2018

i07360155

# **Water Temperature Regulator - Remove and Install**

SMCS - 1355-010

## **Removal Procedure**

---

### **NOTICE**

**Keep all parts clean from contaminants.**

**Contaminants may cause rapid wear and shortened component life.**

---

---

### **NOTICE**

**Care must be taken to ensure that fluids are contained during performance of inspection, maintenance, testing, adjusting and repair of the product. Be prepared to collect the fluid with suitable containers before opening any compartment or disassembling any component containing fluids.**

**Dispose of all fluids according to local regulations and mandates.**

---

1. Drain the coolant from the cooling system into a suitable container for storage or disposal. Refer to Operation and Maintenance Manual, "Cooling System Coolant - Drain" for more information.
-

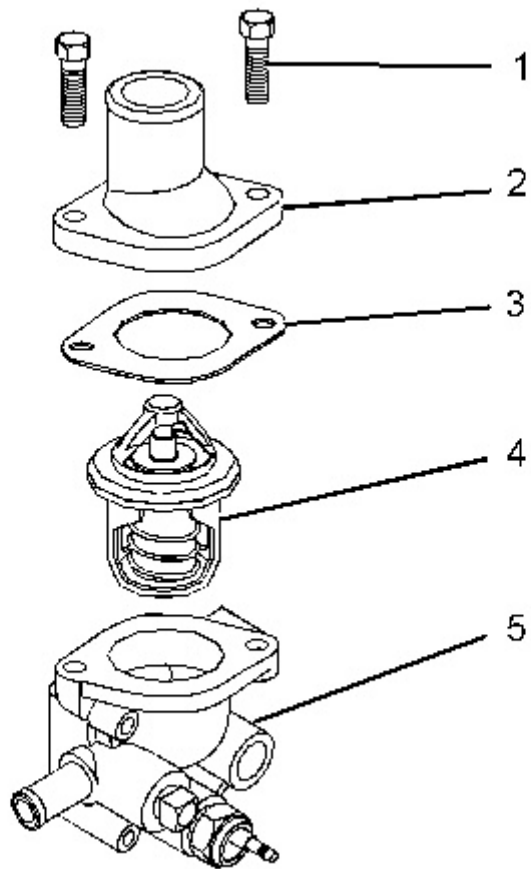

---

Illustration 1  
Typical example

g01327027

2. Remove fasteners (1).

3. Remove outlet connection (2).

**Note:** Identify the orientation of the outlet connection for installation.

4. Remove joint (3).

5. Remove water temperature regulator (4) from water temperature regulator housing (5).

## Installation Procedure

---

### NOTICE

**Keep all parts clean from contaminants.**

**Contaminants may cause rapid wear and shortened component life.**

---

1. Inspect the water temperature regulator for wear, damage, and correct operation. Refer to Systems Operation, Testing and Adjusting, "Water Temperature Regulator - Test" for more information. If necessary, replace the water temperature regulator.
2. Ensure that the mating surfaces of the outlet connection and the water temperature regulator housing are clean and free from damage.

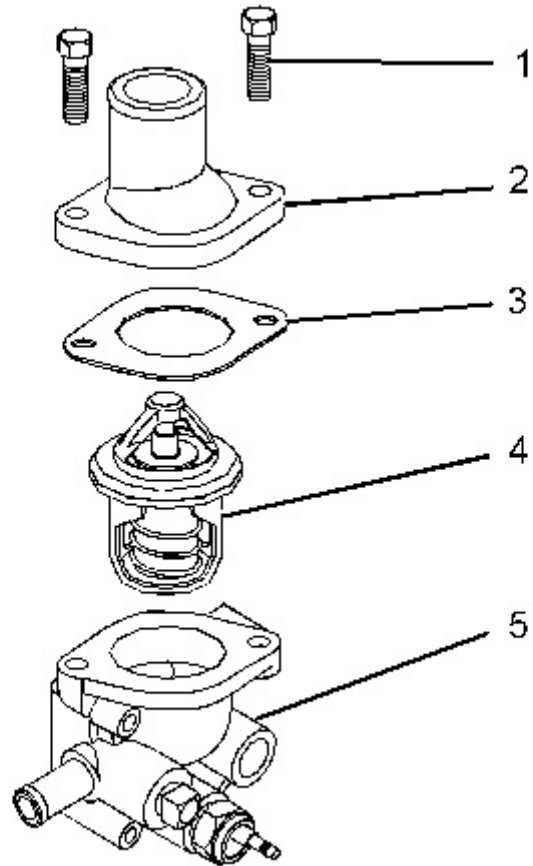

---

Illustration 2

g01327027

Typical example

3. Install water temperature regulator (4) to water temperature regulator housing (5). Refer to Specifications, "Water Temperature Regulator Housing" for the correct orientation of the water temperature regulator.
4. Install a new joint (3).
5. Install outlet connection (2) to water temperature regulator housing (5).

**Note:** Ensure the correct orientation of the outlet connection.

6. Install fasteners (1).

For the C1.1 engine, tighten the fasteners to a torque of 6 N·m (53 lb in).

For C1.5 and C2.2 engines, tighten the fasteners to a torque of 14 N·m (124 lb in).



Thank you so much for reading.  
Please click the “Buy Now!”  
button below to download the  
complete manual.



After you pay.

You can download the most  
perfect and complete manual in  
the world immediately.

Our support email:

[ebooklibonline@outlook.com](mailto:ebooklibonline@outlook.com)