

Product: VIBRATORY COMPACTOR

Model: CB-54B VIBRATORY COMPACTOR LXD

Configuration: CB54B, CB44B Compactor LXD00001-UP (MACHINE) POWERED BY C4.4 Engine

Disassembly and Assembly CB54B Vibratory Asphalt Compactor Machine Systems

Media Number -UENR3258-08

Publication Date -01/12/2014

Date Updated -29/11/2017

i07231507

Piston Motor (Drum Propel) - Disassemble

SMCS - 5058-015

Disassembly Procedure

Table 1

| Required Tools | | | |
|----------------|-------------|-------------------------|-----|
| Tool | Part Number | Part Description | Qty |
| A | 3E-3879 | Eyebolt | 2 |
| B | 150-1782 | Crossblock | 1 |
| | 9U-6754 | Adapter Plate | 1 |
| | 1U-6150 | Adapter Plate | 1 |
| | FT-1129 | Spacer | 1 |
| C | 1U-5230 | Hydraulic Pump Assembly | 1 |
| | 4C-5660 | Threaded Adapter | 2 |
| | 5P-5247 | Hydraulic Puller As | 1 |
| | 8B-7548 | Push-Puller Tool Gp | 1 |
| D | 8B-7554 | Bearing Cup Puller Gp | 1 |
| | 9S-9153 | Puller Jaw | 2 |
| | 1P-0510 | Driver Gp | 1 |

Start By:

- a. Remove the piston motor (drum propel).

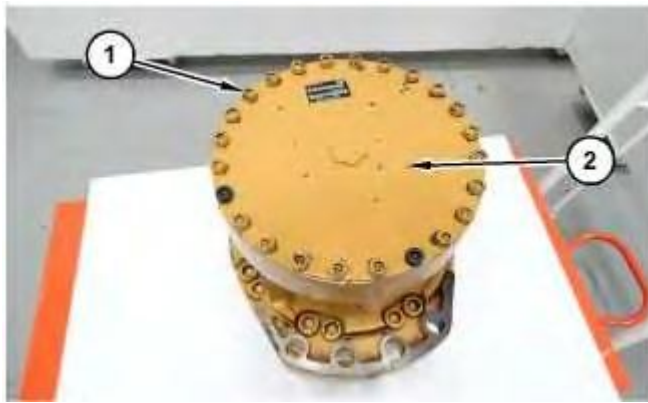

Illustration 1

g06261577

1. Remove bolts (1), cover (2), and the gasket.



Illustration 2

g06261584

2. Use compressed air in the port in housing (4) to remove piston (3).



Illustration 3

g06261588

3. Remove seal ring (5) from piston (3).

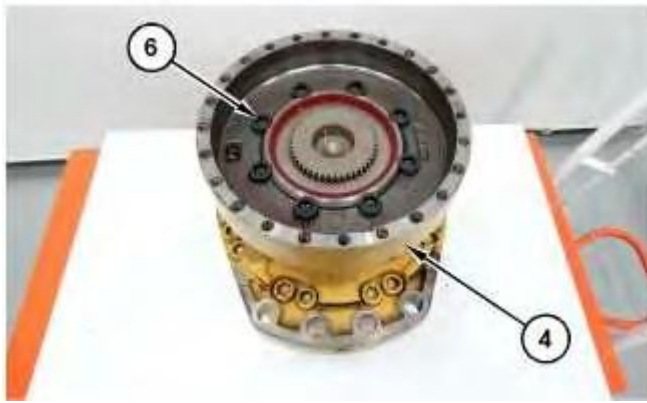

Illustration 4

g06261590

4. Remove bolts (6) and housing (4).



Illustration 5

g06261593

5. Remove seal (7) from housing (4).



Illustration 6

g06261603

Note: Note the orientation of brake discs (8) for assembly purposes.

6. Remove brake discs (8).



Illustration 7

g06261611

7. Remove piston assembly (9).

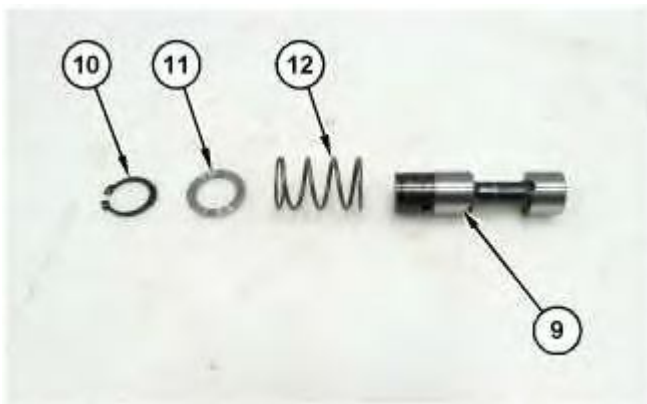

Illustration 8

g06261617

8. Remove retaining ring (10), washer (11), and spring (12) from piston assembly (9).



Illustration 9

g06261621

9. Remove O-ring seal (14) and plug (13).

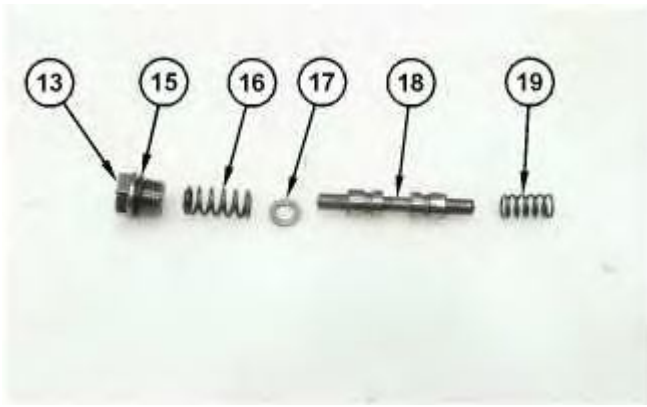

Illustration 10

g06261623

10. Remove O-ring seal (15) from plug (13). Remove spring (16), washer (17), spool (18), and spring (19) from the head assembly.



Illustration 11

g06262011



Illustration 12

g06262013

11. Remove shaft (20) and bolts (21). Attach Tooling (A) to head assembly (22). Remove head assembly (22).



Illustration 13

g06262015

12. Remove seal (23) and distributor (24) from head assembly (22).



Illustration 14

g06262016

13. Remove springs (25) and pin (26) from distributor (24).

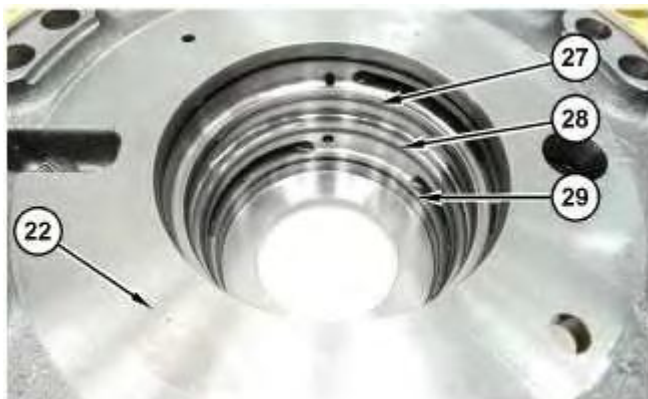

Illustration 15

g06262017

14. Remove O-ring seal (27), O-ring seal (28), and O-ring seal (29) from head (22).



Illustration 16

g06262018

15. Remove cam ring (30) and cylinder block (31).



Illustration 17

g06262019

16. Remove retaining ring (32) and spacer (33) from cylinder block (31).



Illustration 18

g06262020

17. Invert cylinder block (31). Remove retaining ring (34) and spacer (35) from cylinder block (31).

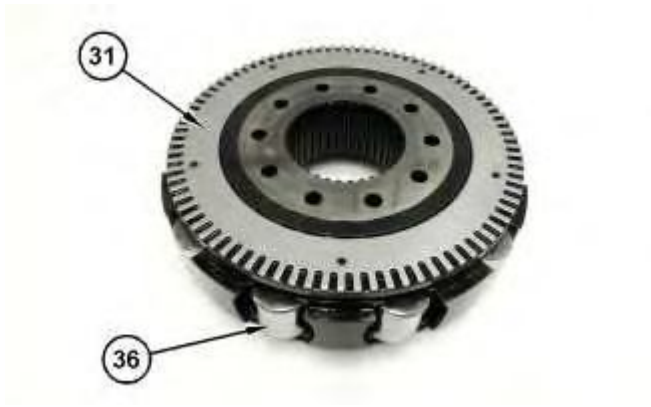

Illustration 19

g06262021

18. Remove piston assemblies (36) from cylinder block (31).



Illustration 20

g06262025

19. Remove piston ring (37) and roller (38) from piston assembly (36).

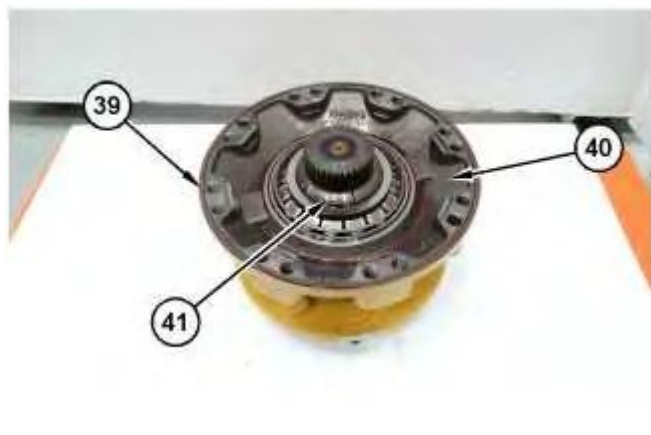

Illustration 21

g06262557

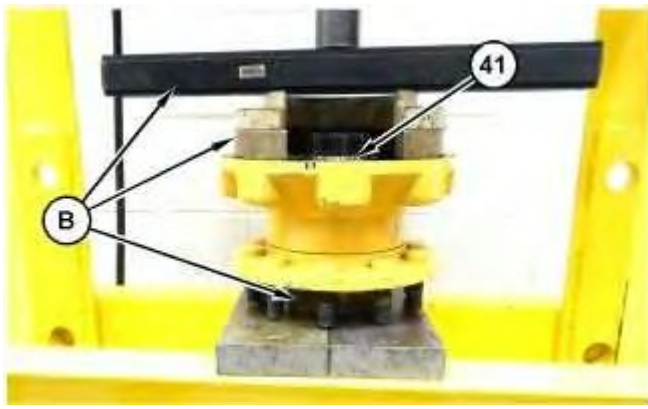

Illustration 22

g06262028

20. Remove O-ring seal (39) from housing (40). Use Tooling (B) and a suitable press to remove split ring (41).

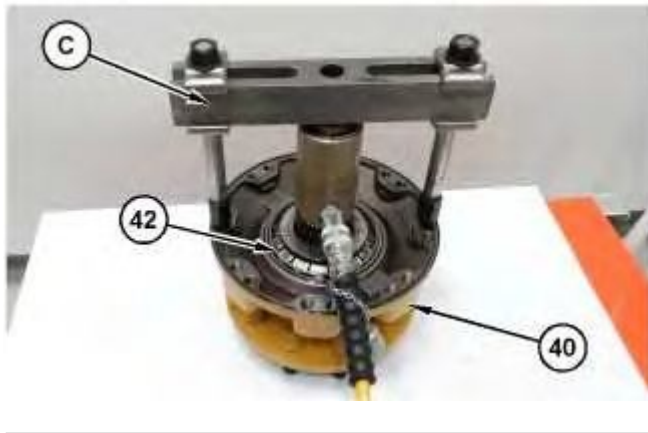

Illustration 23

g06262053

21. Use Tooling (C) to remove bearing cone (42) and housing (40).



Illustration 24

g06262056

22. Remove bearing cup (43) from housing (40).



Illustration 25

g06262058

23. Remove duo cone seal (44) and bearing cup (45) from housing (40).



Illustration 26

g06262059

24. Remove lip seal (46) from housing (40).



Illustration 27

g06262060

25. Remove duo cone seal (47) from flange assembly (48).
-



Illustration 28

g06262062

Note: Damage to bearing cone (49) will occur.

26. Use Tooling (D) to remove bearing cone (49) from flange assembly (48).

Product: VIBRATORY COMPACTOR

Model: CB-54B VIBRATORY COMPACTOR LXD

Configuration: CB54B, CB44B Compactor LXD00001-UP (MACHINE) POWERED BY C4.4 Engine

Disassembly and Assembly CB54B Vibratory Asphalt Compactor Machine Systems

Media Number -UENR3258-08

Publication Date -01/12/2014

Date Updated -29/11/2017

i06901484

Piston Motor (Drum Propel) - Assemble

SMCS - 5058-016

Assembly Procedure

Table 1

| Required Tools | | | |
|----------------|-------------|--------------------------|-----|
| Tool | Part Number | Part Description | Qty |
| A | 136-1452 | Retaining Ring Pliers As | 1 |
| B | 1P-1863 | Retaining Ring Pliers | 1 |
| C | - | Loctite 243 | - |
| D | - | Loctite 263 | - |

Note: Cleanliness is an important factor. Before assembly, all parts should be thoroughly cleaned in cleaning fluid. Allow the parts to air dry. Wiping cloths or rags should not be used to dry parts. Lint may be deposited on the parts which may cause later trouble. Inspect all parts. If any parts are worn or damaged, use new parts for replacement.

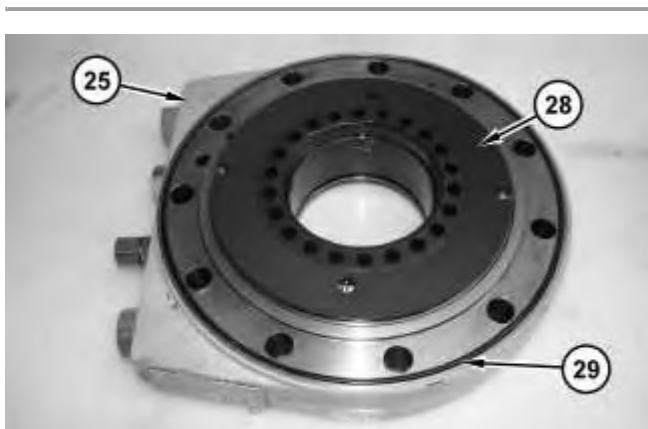

1. Install valve plate (28) to distribution block (25).
2. Install O-ring seal (29) to distribution block (25).
3. Turn over distribution block (25). Place a continuous bead of Tooling (C) around distribution block (25).



Illustration 2

4. Install distribution block (25) and bolts (26). Tight bolts (26) to a torque of 230 ± 23 N·m (170 ± 17 lb ft).
5. Install O-ring seal (27).



Illustration 3

6. Install O-ring seal (24) to ring gear (23).
-

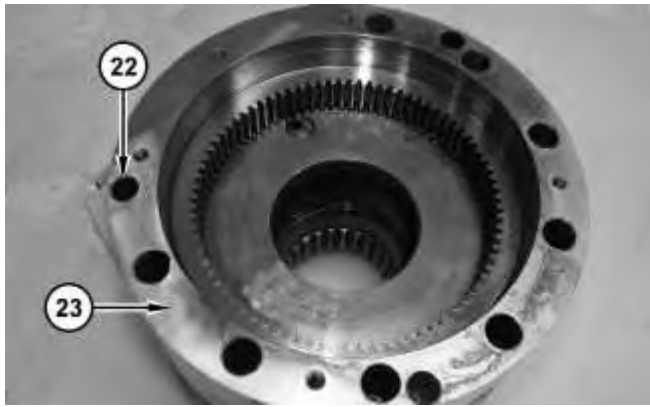

Illustration 4

g01802520

7. Install ring gear (23) and bolts (22). Tight bolts (22) to a torque of $35 \pm 3.5 \text{ N}\cdot\text{m}$ ($26 \pm 3 \text{ lb ft}$).

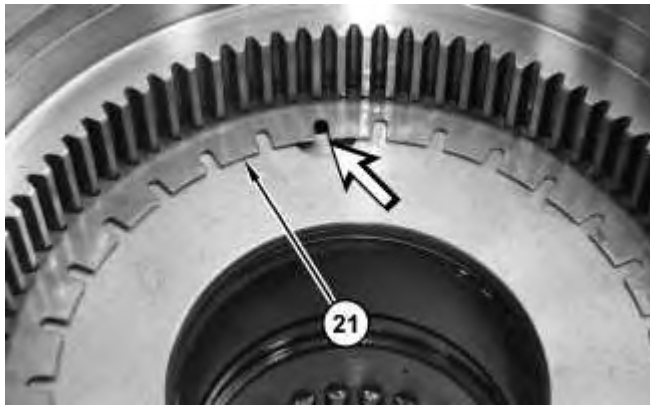

Illustration 5

g01802553

Note: Align the feeder passage of the cover to the disc.

8. Install disc (21).

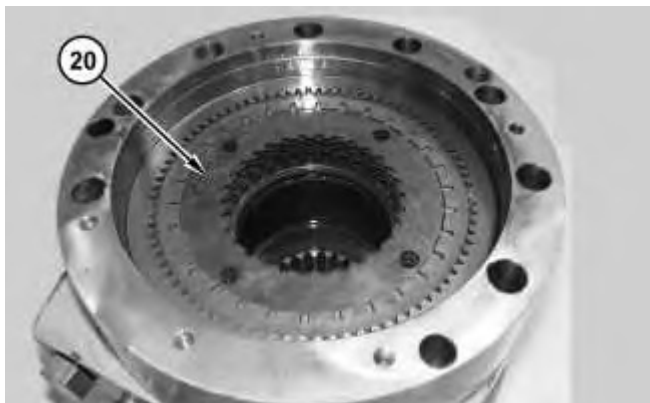

Illustration 6

g01802555

9. Install brake discs (20).

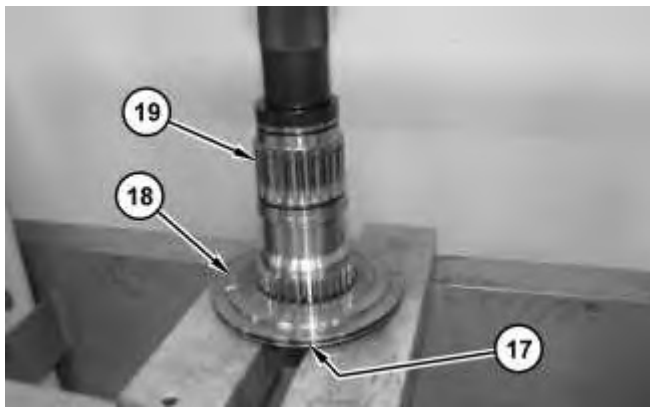

Illustration 7

g01802561

10. Use a suitable press and install brake piston (18) and bearing (17) to shaft (19).

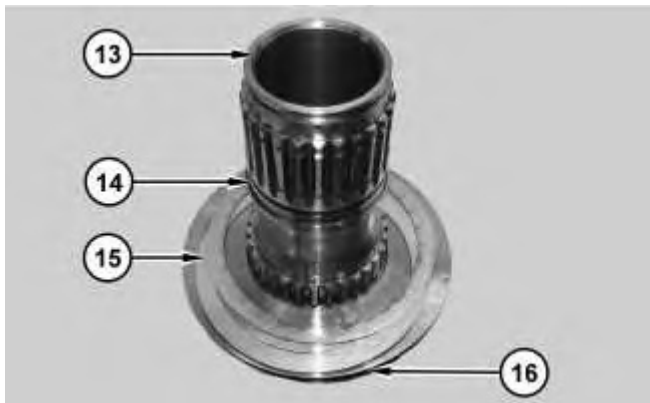

Illustration 8

g01802558

11. Install O-ring seal (16) to shaft assembly (13).
12. Install shims (15).
13. Install O-ring seal (14) to shaft assembly (13).



Illustration 9

g01802559

14. Install shaft assembly (13).

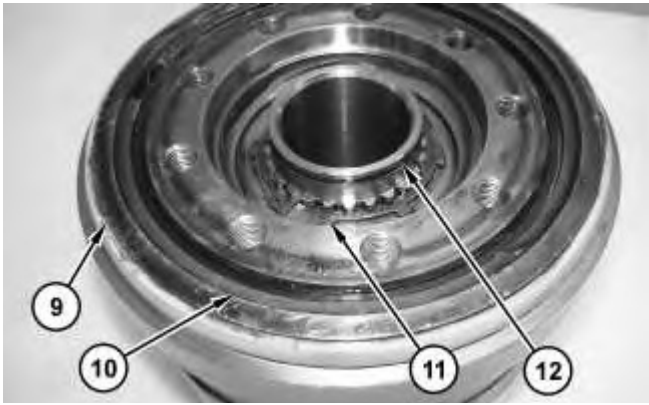

Illustration 10

g01802563

15. Install O-ring seal (12).

16. Use Tooling (B) and install retaining ring (11).

17. Use Tooling (A) and install retaining ring (10).

18. Install seal (9).

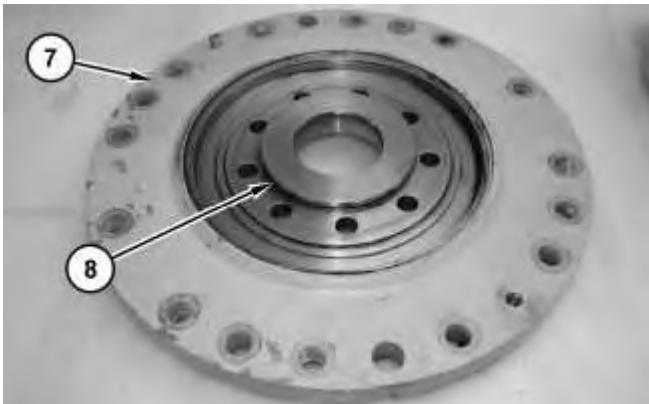

Illustration 11

g01802593

Note: Some adapter plates may not have O-ring seal (8).

19. Install O-ring seal (8) to adapter plate (7), if equipped.

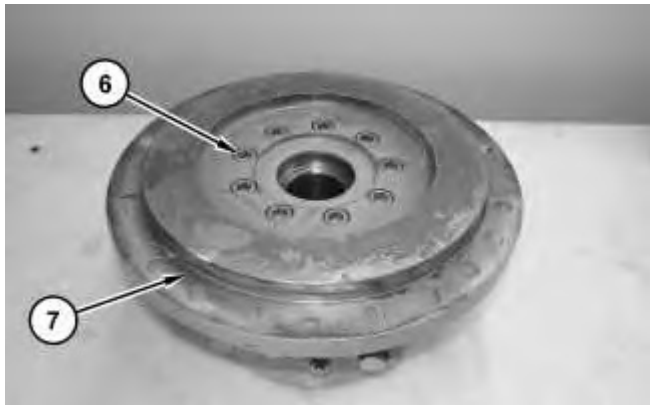

Illustration 12

g01802613

20. Use two people and install adapter plate (7). The weight of adapter plate (7) is approximately 27 kg (60 lb). Apply Tooling (D) to bolts (6). Install bolts (6). Tight bolts (6) to a torque of 355 ± 3.5 N·m (262 ± 2.6 lb ft).

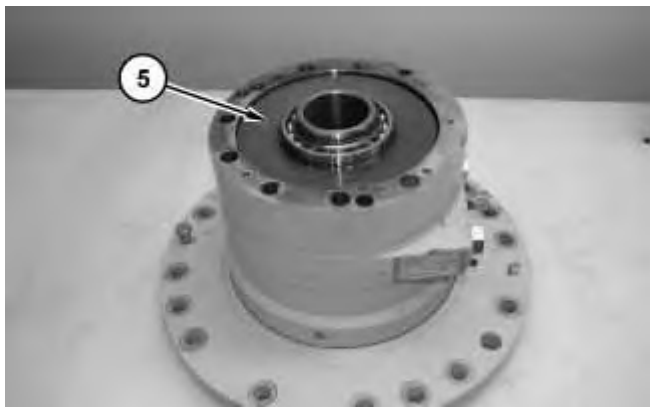

Illustration 13

g01802633

21. Install belleville washer (5).



Illustration 14

g01802636

22. Install O-ring seal (4) and seal (3) to cover (2).

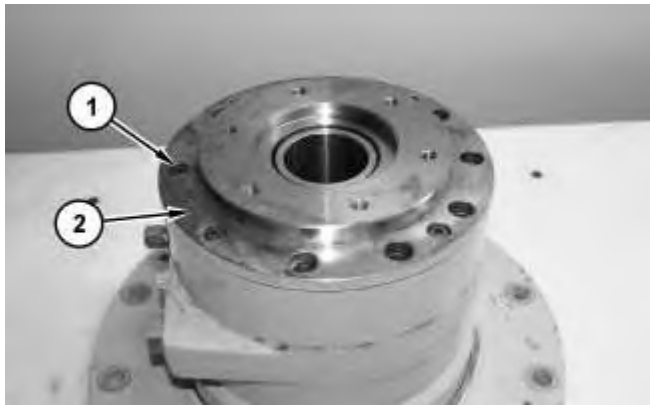

Illustration 15

g01802653

23. Install cover (2) and bolts (1). Apply Tooling (D) to bolts (1). Install bolts (1). Tight bolts (1) to a torque of $35 \pm 3.5 \text{ N}\cdot\text{m}$ ($26 \pm 2.6 \text{ lb ft}$).

End By:

- a. Install the piston motor (drum propel).
-

Product: VIBRATORY COMPACTOR

Model: CB-54B VIBRATORY COMPACTOR LXD

Configuration: CB54B, CB44B Compactor LXD00001-UP (MACHINE) POWERED BY C4.4 Engine

Disassembly and Assembly CB54B Vibratory Asphalt Compactor Machine Systems

Media Number -UENR3258-08

Publication Date -01/12/2014

Date Updated -29/11/2017

i07231508

Piston Motor (Drum Propel) - Assemble

SMCS - 5058-016

Assembly Procedure

Table 1

| Required Tools | | | |
|----------------|-------------|----------------------------|-----|
| Tool | Part Number | Part Description | Qty |
| A | 3E-3879 | Eyebolt | 2 |
| B | 1U-6150 | Adapter Plate | 1 |
| | 150-1782 | Crossblock | 1 |
| | 9U-6754 | Adapter Plate | 1 |
| | FT-1129 | Spacer | 1 |
| E | 1U-8697 | Duo-Cone Seal Installer As | 1 |



1. Raise the temperature of bearing (49). Install bearing cone (49) onto flange assembly (48).



Illustration 2

2. Use Tooling (E) to install Duo-Cone seal (47) into flange assembly (48). Refer to Special Instruction, SEHS8364, "Assembly and Installation of Conventional Duo-Cone Seals".



Illustration 3

3. Install lip seal (46) into housing (40).



Illustration 4

4. Install bearing cup (45). Use Tooling (E) to install Duo-Cone seal (44) into housing (40). Refer to Special Instruction, SEHS8364, "Assembly and Installation of Conventional Duo-Cone Seals".



Illustration 5

g06262056

5. Install bearing cup (43) into housing (40).

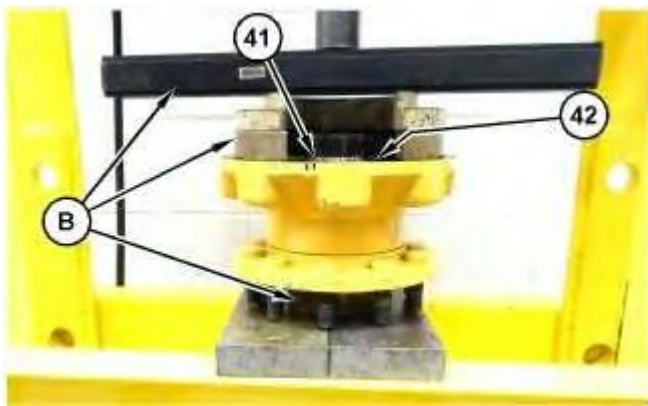

Illustration 6

g06262623

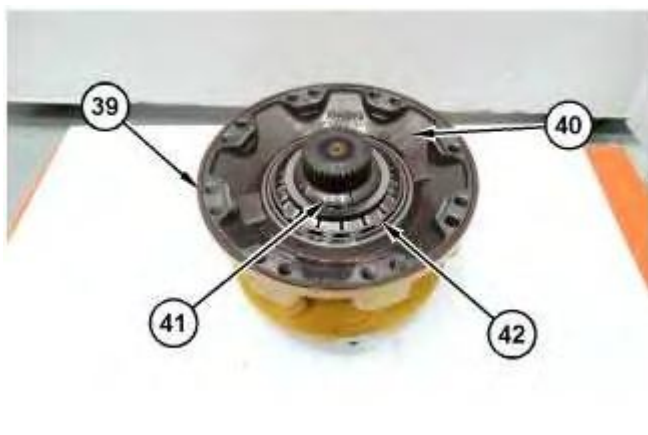

Illustration 7

g06262621

6. Use Tooling (B) and a suitable press to install bearing cone (42), split ring (41), and O-ring seal (39) into housing (40).



Illustration 8

g06262025

7. Install roller (38) and piston ring (37) into piston assembly (36).
-



Illustration 9

g06262021

8. Install piston assemblies (36) into cylinder block (31).
-



Illustration 10

g06262020

9. Install spacer (35) and retaining ring (34) into cylinder block (31).
-



Illustration 11

g06262019

10. Invert cylinder block (31). Install spacer (33) and retaining ring (32) into cylinder block (31).



Illustration 12

g06262018

11. Install cylinder block (31) and cam ring (30).

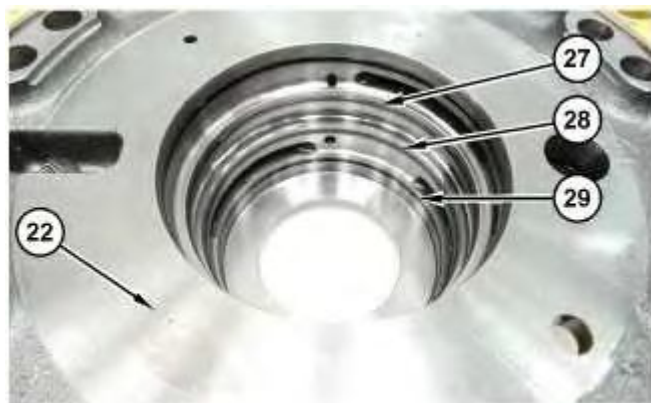

Illustration 13

g06262017

12. Install O-ring seal (29), O-ring seal (28), and O-ring seal (27) into head (22).



Illustration 14

g06262016

13. Install pin (26) and springs (25) into distributor (24).



Illustration 15

g06262015

14. Install distributor (24) and seal (23) into head assembly (22).



Illustration 16

g06262013

Thank you so much for reading.
Please click the “Buy Now!”
button below to download the
complete manual.



After you pay.

You can download the most
perfect and complete manual in
the world immediately.

Our support email:

ebooklibonline@outlook.com