

# ISEKI E3112 MANUAL

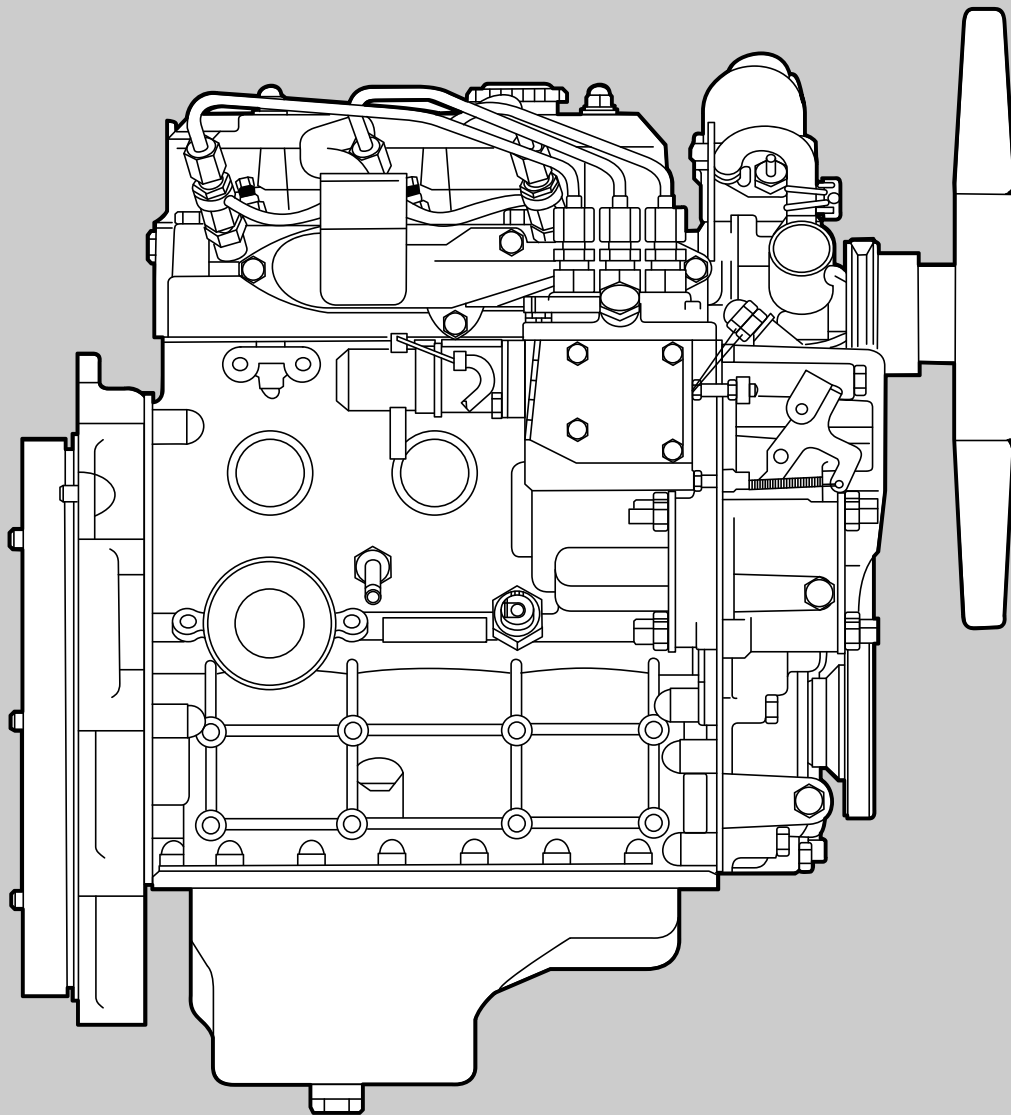



**CHAPTER 1**

**CHAPTER 2**

**CHAPTER 3**

**CHAPTER 4**

**CHAPTER 5**

# **3-cylinder Engines**

## **E3112**

# TABLE OF CONTENTS

<b>TABLE OF CONTENTS</b> .....	<b>3</b>
<b>CHAPTER 1. ENGINE ACCESSORIES</b> .....	<b>7</b>
1. RADIATOR.....	7
2. COOLING FAN AND BELT .....	8
3. AIR CLEANER.....	9
4. FUEL SYSTEM.....	9
5. TROUBLE SHOOTING.....	11
<b>CHAPTER 2. ENGINES</b> .....	<b>13</b>
1. REMOVAL OF THE ENGINE FROM THE CHASSIS .....	13
2. SPECIFICATIONS .....	14
3. INSPECTION AND ADJUSTMENT.....	16
3.1. INSPECTION OF ENGINE OIL .....	16
3.2. INSPECTION OF FAN BELT .....	16
3.3. INSPECTION AND ADJUSTMENT OF VALVE CLEARANCES .....	18
3.4. INSPECTION AND ADJUSTMENT OF NOZZLE OPENING PRESSURE AND INJECTION TIMING.....	18
3.4.1. Adjustment of the valve opening pressure of the injection nozzles. ....	18
3.4.2. Inspection of oil tightness of valve seats .....	19
3.4.3. Spraying condition of injection nozzle .....	19
3.4.4. Inspection and adjustment of injection timing.....	19
3.5. COMPRESSION AND IDLING SPEEDS.....	21
3.5.1. Inspection of compression.....	21
3.5.2. Inspection and adjustment of the idling speeds .....	21
3.6. INSPECTION OF WATER PUMP.....	21
3.6.1. Inspection of the pump and pulley.....	21
3.6.2. Inspection of the bearing unit .....	22
3.7. INSPECTION OF THERMOSTAT.....	22
4. ENGINE BODY .....	22
4.1. CYLINDER HEAD.....	22
4.1.1. REMOVAL OF THE CYLINDER HEAD .....	23
4.1.2. DISASSEMBLY .....	24
4.1.3. INSPECTION.....	24
4.1.4. DISASSEMBLY AND INSPECTION OF THE ROCKER ARM SHAFT .....	27
4.1.5. INSPECTION OF THE PUSH RODS .....	28
4.1.6. INSTALLATION OF THE CYLINDER HEAD .....	28
4.2. GEAR CASE.....	30
4.2.1. EXPLODED VIEW.....	30
4.2.2. REMOVAL OF THE GEAR CASE .....	30
4.2.3. RE-INSTALLATION OF THE GEAR CASE .....	31
4.3. CYLINDER BLOCK .....	32
4.3.1. EXPLODED VIEW.....	32
4.3.2. DISASSEMBLY OF THE CYLINDER BLOCK.....	33
4.3.3. INSPECTION OF CYLINDER BLOCK, CRANKSHAFT, CAMSHAFT, AND TAPPETS.....	34

## **SFH220 & SFH240 FRONT MOWER SERVICE MANUAL**

4.3.4. INSPECTION OF PISTONS AND CONNECTING RODS.....	39
4.3.5. ASSEMBLY OF PISTON AND CONNECTING ROD.....	41
4.3.6. INSTALLATION OF CRANKSHAFT.....	42
4.3.7. INSTALLATION OF PISTON/CONNECTING-ROD ASSEMBLIES.....	43
4.3.8. INSTALLATION OF REAR OIL SEAL.....	44
4.3.9. INSTALLATION OF STRAINER AND OIL PAN.....	44
4.3.10. INSTALLATION OF REAR PLATE AND FLYWHEEL.....	44
4.3.11. INSTALLATION OF FRONT PLATE AND GEARS.....	45
5. SERVICE STANDARDS.....	48
6. TIGHTENING TORQUE OF MAJOR FASTENERS.....	55
7. TROUBLESHOOTING.....	56
<b>CHAPTER 3. LUBRICATION SYSTEM.....</b>	<b>63</b>
1. GENERAL DESCRIPTION.....	63
1.1. LUBRICATION DIAGRAM.....	63
1.2. RELIEF VALVE.....	64
1.3. OIL FILTER.....	64
1.4. EXPLODED VIEW OF OIL PUMP.....	65
2. REMOVAL, DISASSEMBLY, INSPECTION AND RE-INSTALLATION OF OIL PUMP.....	66
2.1. REMOVAL OF OIL PUMP.....	66
2.2. DISASSEMBLY OF OIL PUMP.....	66
2.3. INSPECTION.....	66
2.4. INSTALLATION OF OIL PUMP.....	67
3. OIL FILTER.....	67
3.1. REMOVAL OF OIL FILTER.....	67
3.2. INSTALLATION OF OIL FILTER.....	67
<b>CHAPTER 4. COOLING SYSTEM.....</b>	<b>69</b>
1. COOLING SYSTEM DIAGRAM.....	69
2. THERMOSTAT.....	69
2.1. REMOVAL OF THERMOSTAT.....	69
2.2. INSTALLATION OF THERMOSTAT.....	69
2.3. INSPECTION OF THERMOSTAT.....	69
3. WATER PUMP.....	70
3.1. REMOVAL OF WATER PUMP.....	70
3.2. INSTALLATION OF WATER PUMP.....	70
3.3. INSPECTION OF WATER PUMP.....	70
<b>CHAPTER 5. FUEL SYSTEM.....</b>	<b>71</b>
1. INJECTION PUMP CONSTRUCTION.....	71
2. REMOVAL, DISASSEMBLY, INSPECTION, RE-ASSEMBLY, AND INSTALLATION.....	72
2.1. REMOVAL OF INJECTION PUMP.....	72
2.2. DISASSEMBLY OF INJECTION PUMP.....	72
2.3. INSPECTION OF INJECTION PUMP.....	73
2.4. RE-ASSEMBLY OF INJECTION PUMP.....	73
2.5. ADJUSTMENT OF INJECTION VOLUME AND ADJUSTMENT CONDITIONS.....	75
3. INJECTION NOZZLES AND HOLDERS.....	76
3.1. REMOVAL OF INJECTION NOZZLES AND HOLDERS.....	76

3.2. INSPECTION OF INJECTION NOZZLES .....	76
3.3. DISASSEMBLY AND WASHING OF INJECTION NOZZLES.....	77
3.4. INSTALLATION OF INJECTION NOZZLES AND HOLDERS .....	78
3.5. INSTALLATION OF INJECTION NOZZLES AND HOLDERS .....	78
4. GOVERNOR.....	79
4.1. GOVERNOR CONSTRUCTION.....	79
4.2. GOVERNOR OPERATION .....	80
5. ANGLEICHUNG DEVICE .....	80
5.1. ANGLEICHUNG OPERATION.....	80
6. STARTER .....	81
6.1. CONSTRUCTION.....	81
6.2. REMOVAL AND DISASSEMBLY OF STARTER.....	82
6.3. INSPECTION OF COMPONENTS.....	82
6.4. REASSEMBLY OF STARTER .....	85
6.5. INSPECTION OF THE STARTER AFTER REMOVAL FROM THE TRACTOR .....	86
6.6. PERFORMANCE TEST.....	86
6.7. INSTALLATION OF THE STARTER.....	87
7. ALTERNATOR.....	88
7.1. EXPLODED VIEW, SPECIFICATIONS, AND PERFORMANCE CURVES .....	88
7.2. TROUBLESHOOTING.....	89
7.3. REMOVAL AND DISASSEMBLY .....	89
7.4. INSPECTION.....	91
7.5. RE-ASSEMBLY .....	94
8. GLOW PLUGS.....	95
8.1. SECTIONAL VIEW .....	95
8.2. REMOVAL, INSPECTION, AND RE-ASSEMBLY.....	96

# CHAPTER 1. ENGINE ACCESSORIES

## 1. RADIATOR

### (1) CONSTRUCTION

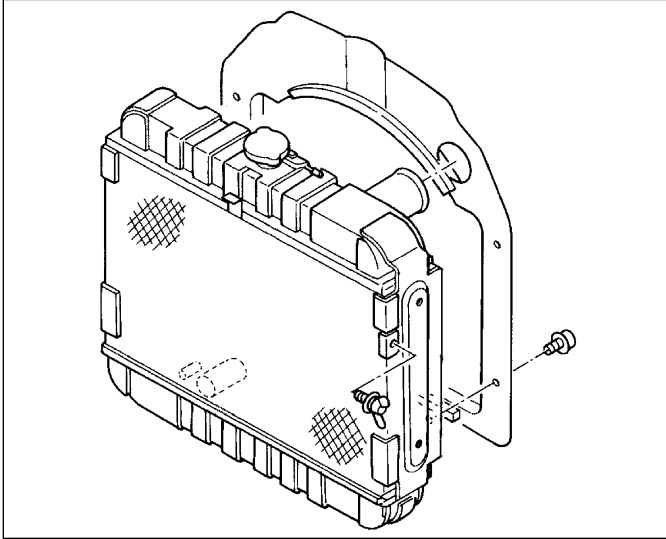

Fig. 1-1

### (2) REMOVAL AND RE-ASSEMBLE

Remove and reassemble the radiator in accordance with the instruction of "DISASSEMBLY OF FUNCTIONAL BLOCKS."

**NOTE:** Coolant should be replaced if it becomes contaminated with rust or sludge. Before adding new coolant, flush inside of the radiator and engine block with clean water

### PRECAUTION FOR FILLING ANTI FREEZE

Follow manufacturer's instructions for mixing ratio of antifreeze.

Antifreeze should be blended well with water before filling.

When the coolant level is lowered due to evaporation, maintain the level by adding water, not by using an antifreeze solution.

When the coolant level is lowered due to leaks, maintain the level by adding an antifreeze solution of the same mixing ratio.

Take care not to spill antifreeze on painted parts.

### (3) INSPECTION FOR RADIATOR WATER LEAKS

Water leaks are liable to occur at the fitting portion between the upper tank and the core section or between the lower tank and the core section.

Test the radiator for leaks with compressed air in a manner as shown below.

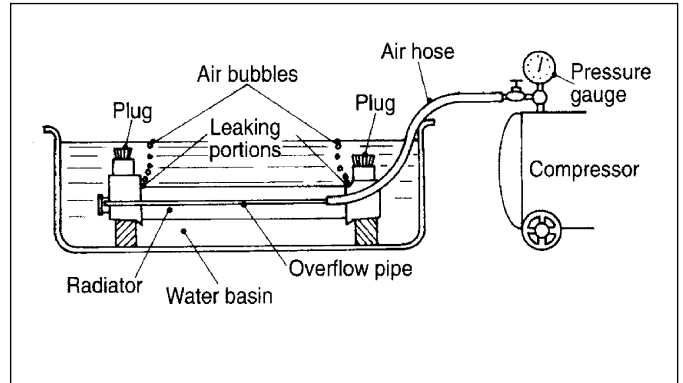

Fig. 1-2

Or check for leaks with a radiator cap tester as shown as below.

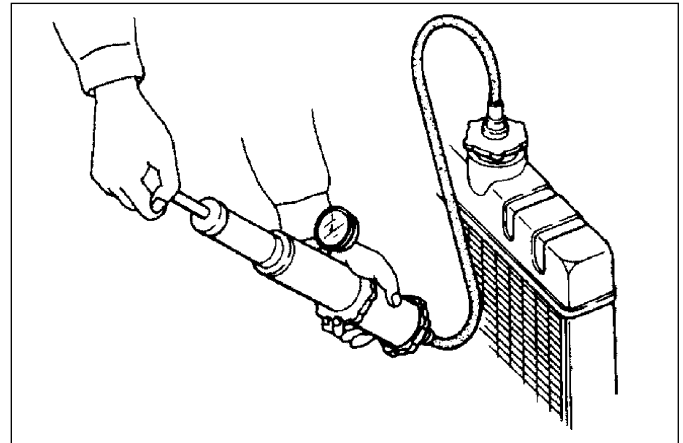

Fig. 1-3

**NOTE:** Never allow the test pressure to exceed 1kgf/cm<sup>2</sup> (14.2 psi) in both cases.

**SFH220 & SFH240 FRONT MOWER SERVICE MANUAL**

(4) INSPECTION FOR RADIATOR CLOGGING

Inside:

Clean the radiator inside as shown below.

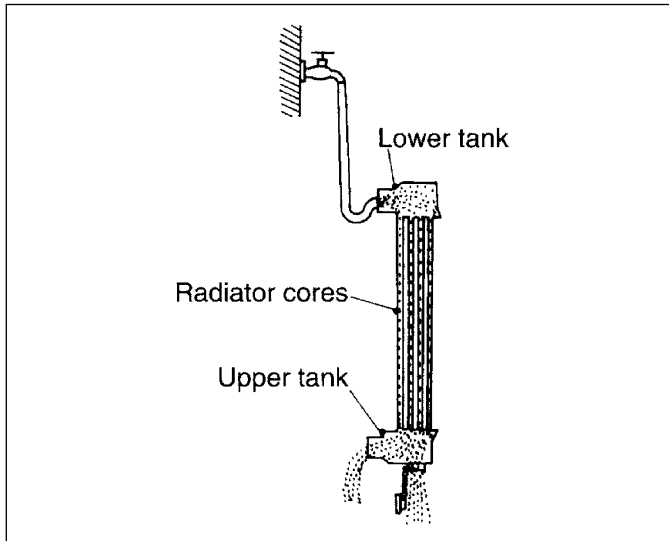

Fig. 1-4

Clean with a detergent.

Outside:

Clean the radiator screen (wire mesh).

After the tractor has been operated in dusty conditions, check the screen daily and clean if necessary.

Clean the radiator cores by applying water spray or compressed air so as to form a right angle with the radiator cores, moving water application in parallel.

*NOTE: When cleaning the radiator cores with pressurized water be sure to apply it at a right angle to the cores. Slanted applications might deform their cooling fins.*

Clean the radiator cores by applying water spray or compressed air so as to form a right angle with the radiator cores, moving water application in parallel.

*NOTE: When cleaning the radiator cores with pressurized water be sure to apply it at a right angle to the cores. Slanted applications might deform their cooling fins.*

(5) VISUAL INSPECTION OF THE EXTERIOR PARTS

When the radiator exterior is corroded, cracked, or badly damaged and the radiator core fins are crushed or damaged, replace the radiator. Also replace damaged or fatigued water hoses. Retighten loose hose clamps securely if water is leaking through the hose clamps, or replace them if necessary.

**2. COOLING FAN AND BELT**

(1) SPECIFICATION

Cooling fan ..... 320 mm (12.6 inches) 5 blades  
 Drive ..... Belt  
 Pulley ratio.....Crank/Fan106/82=1.29

(2) ADJUSTMENT OF BELT

To adjust belt tension, loosen the alternator pivot bolt and nut and tensioning bracket bolt. Pull outward on top the alternator to correctly tension belt and tighten the bolt first and then tighten the pivot bolt.

*NOTE: Do not pry against the alternator housing or pulley. Carefully pry against the alternator-mounting flange to prevent damage.*

Belt deflection at "X" point	13 to 16 mm
------------------------------	-------------

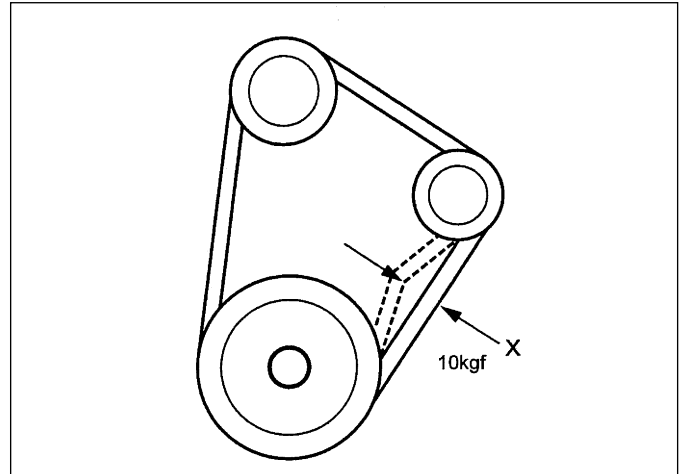

Fig. 1-5

**3. AIR CLEANER**

**(1) REMOVAL AND REASSEMBLY**

Release clips on the cover. Remove the element. Examine the element and seals for damage and brittleness. If the element is damaged in any way, it must be replaced. Reassemble in reverse order of removal and clip securely.

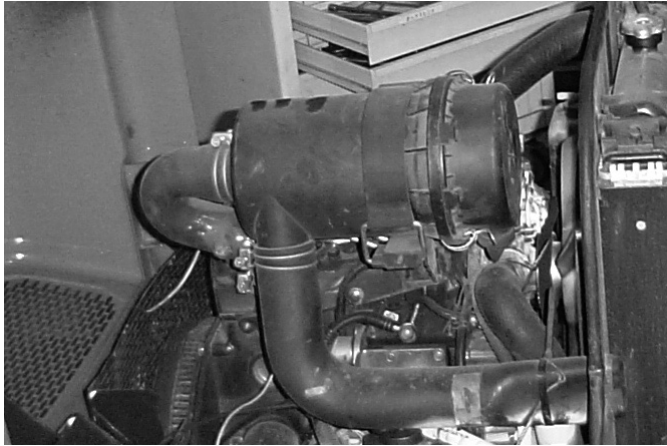

Fig. 1-6

**(2) INSPECTION**

Inspect the air cleaner visually for cracks, deformation, or other damage.

Check the rubber packing at each joint, rubber pipes and the evacuator valve.

Inspect the paper element.

**(3) CLEANING ELEMENT**

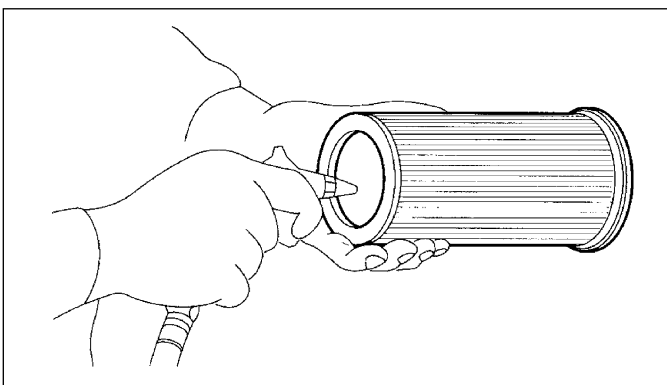

Fig. 1-7

The element may be cleaned (if in serviceable condition) using the following procedures.

Using compressed air [not exceeding 200 kPa (30 psi)] from the inside of the element, remove loose dirt, grass, chaff, etc.

Be careful not to damage element pleats with air flow.

If the element is coated with oil or soot:

- a. Prepare solution of warm water and nonfoaming detergent.
- b. Soak the element for thirty minutes.
- c. Agitate the element in solution until oil and soot are loosened.
- d. Rinse the element until rinse water is clear.
- e. Allow the element to completely dry. Do not dry by using compressed air or heat.

After cleaning (or washing) the element examine for pinholes, punctures, or tears. If the element paper, canister or seal show any signs of physical damage, the element must be replaced.

*NOTE: Replace an element, which has already been washed five times.*

**4. FUEL SYSTEM**

**(1) FUEL CIRCUIT**

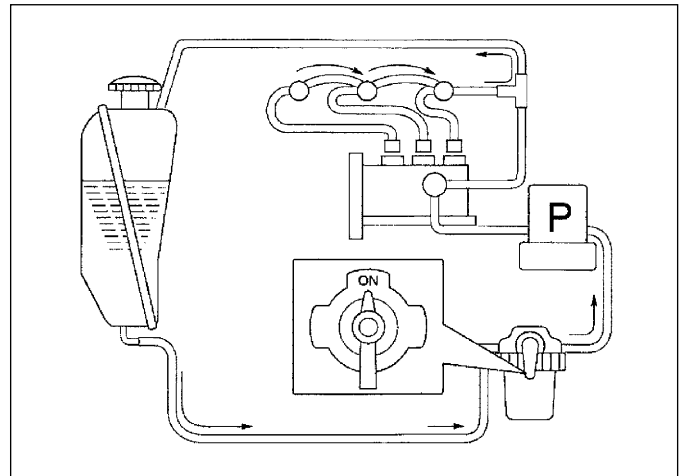

Fig. 1-8

## SFH220 & SFH240 FRONT MOWER SERVICE MANUAL

### (2) INSPECTION

Use only clean diesel fuel of correct grade. Introduction of water or dirt into the fuel tank or other part of the fuel system can cause repeated plugging of the fuel filter and possible injection pump and injector damage.

### (3) FUEL FILTER

To replace the fuel filter element or clean sediment, turn the fuel valve to the OFF position (top). Inspect the filter element sediment bowl and O-ring.

Examine the small O-ring in the filter head and replace as necessary.

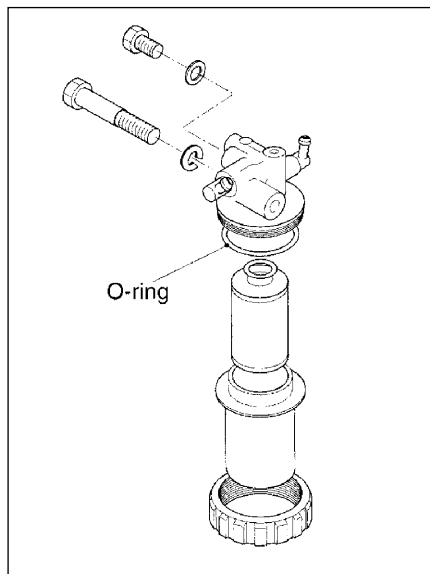

Fig. 1-9

### (4) AIR-BLEEDING

#### PROCEDURE:

- Turn key switch "ON".
- Fill the fuel tank.
- Turn the fuel valve (1) to "ON".
- Loosen the air-bleeding screw (2) and let air bubbles out.
- Loosen the air-bleeding screw of the fuel injection pump and let air bubbles out of the pump.

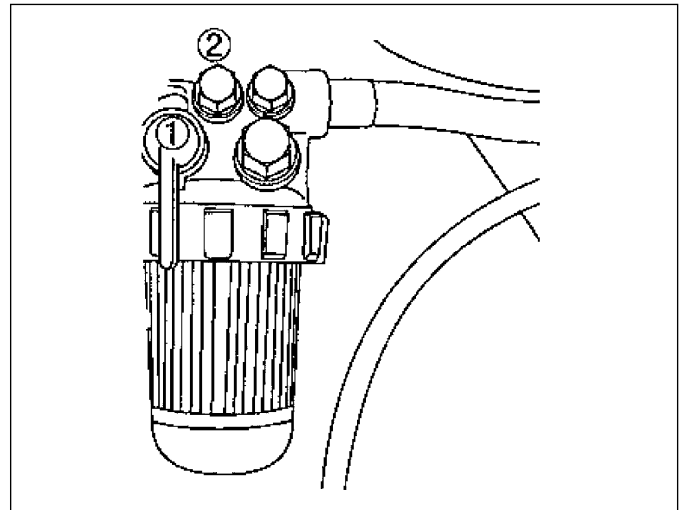

Fig. 1-10



**CAUTION:** Fuel emitted from loosened injection lines is under high pressure. Keep hands and face away when the engine is cranked. Clean all spilled fuel following air-bleeding procedure.

**IMPORTANT:** When turning key switch ON, don't start engine.

Thank you so much for reading.  
Please click the “Buy Now!”  
button below to download the  
complete manual.



After you pay.

You can download the most  
perfect and complete manual in  
the world immediately.

Our support email:

[ebooklibonline@outlook.com](mailto:ebooklibonline@outlook.com)