

Operation Manual

Yanmar Marine Diesel Engine

6CXM-GTE2

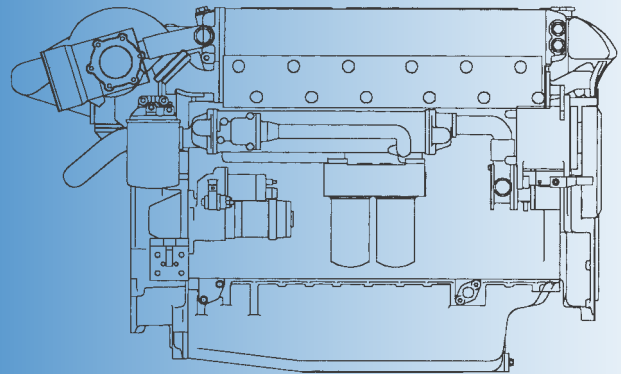

Be sure to read this manual for safe and proper operation.
Store this manual carefully after use.

1. For Safe Operation

- 1.1 Warning Symbols
- 1.2 Safety Precautions
- 1.3 Location of Product Safety Labels

2. Product Explanation

- 2.1 Use & Driving System
- 2.2 Engine Specifications
- 2.3 Location of Component
- 2.4 Operation Equipment
- 2.4. 1 Instruments

3. Before Operation

- 3.1 Fuel, Lube Oil and Cooling Water
- 3.2 Supplying Fuel
- 3.3 Supplying Engine Lube Oil
- 3.4 Supplying Cooling Water
- 3.5 Cranking
- 3.7 Checking the Lube Oil and Cooling Water

4. How to Operate

- 4.1 Inspection Before Starting
- 4.2 Checking the Instrument Panel and Alarm Devices
- 4.3 Starting
- 4.4 Adjusting the Engine Speed
- 4.5 Check During Operations
- 4.6 Stopping the Engine
- 4.7 Operation Procedure
- 4.8 Long-Term Storage

5. Maintenance & Inspection

- 5.1 List of Periodic Inspections
- 5.2 Periodic Inspection Items
 - 5.2.1 Inspection After Initial 50 Hrs. of Operation
 - 5.2.2 Inspection Every 50 Hours
 - 5.2.3 Inspection Every 250 Hrs. or 1 yr
 - 5.2.4 Inspection Every 500 Hrs. or 2 yrs.
 - 5.2.5 Inspection Every 1000 Hrs. or 4 yrs.
- 5.3 Replacement Parts

6. Trouble and Troubleshooting

- 6.1 Simple problems and the appropriate countermeasures
- 6.2 Consulting Your Yanmar Dealer or Distributor

1

Following the precautions described in this manual will enable you to use this engine with complete satisfaction. Failure to observe any of the rules and precautions, however, may result in injury, burns, fires and engine damage. Read this manual carefully and be sure you fully understand it before beginning operation.

1.1 Warning Symbols

These are the warning signs, which are used in this manual and on the products. Pay special attention to them.

DANGER

DANGER indicates an imminently hazardous situation, which, if not avoided, **WILL** result in death or serious injury.

WARNING

WARNING indicates a potentially hazardous situation, which, if not avoided, **COULD** result in death or serious injury.

CAUTION

CAUTION indicates a potentially hazardous situation, which, if not avoided, **MAY** result in minor or moderate injury. It may also be used to alert against unsafe practices.

The descriptions captioned by **[NOTICE]** are for particularly important cautions for handling. If you ignore them, the performance of your machine may deteriorate, leading to trouble.

1

1.2 Safety Precautions

Precautions for Operation

Burns from Scalding



- Never remove the filler cap of the fresh water cooler while the engine is still hot. Steam and hot water will spurt out and seriously burn you. Wait until the water temperature has dropped, then wrap a cloth around the cap and

loosen it slowly. After inspection, refasten the filler cap firmly. If the cap is not secure, steam or scalding water may be emitted during operation causing burns.

Proper Ventilation of the Battery Area



- Be sure the area around the battery is well ventilated and there is nothing which could start a fire. During operation and charging, hydrogen gas is emitted from the battery and can easily be ignited.

Fires from Oil Ignition



- Be sure to use the correct type of fuel when refueling. Mistakenly filling with gasoline, or the like, will result in ignition.
- Be sure to stop the engine before refueling. If you spill fuel, wipe such spillage carefully.

- Never place oils or other flammable material close to the engine as this could result in ignition.

Exhaust Gas Poisoning



- Be sure to establish good ventilation in the engine room with windows, vents, or other ventilation equipment. Check again during operation to be sure that ventilation is good. Exhaust gas contains poisonous carbon monoxide and should not be inhaled.

Moving Parts



- Do not touch the moving parts of the engine (propeller shaft, V-belt, PTO-pulley, etc.) during operation or let your clothing get caught in them as this can result in injury.

- Never operate the engine without the covers on the moving parts.
- Before starting the engine, check to see that any tools or cloths used in maintenance have been removed from the area.

1

Burns from Contact with Hot Engine Parts



- The whole engine is hot during operation and immediately after stopping. The turbocharger, exhaust manifold, exhaust pipe and engine are very hot. Never touch these parts with your body or clothing.

Alcohol



- Never operate the engine while you are under the influence of alcohol, when you are ill or feel unwell as this results in accidents.

Safety Precautions for Inspection

Battery Fluid



- Battery fluid is diluted sulfuric acid. It can blind you if it gets in your eyes, or burn your skin. Keep the fluid away from your body. If you get any on you, wash it off immediately with a large quantity of fresh water.

Fire due to Electric Short-Circuits



- Always turn off the battery switch or detach the earth cable (-) before inspecting the electrical system. Failure to do so could cause short-circuiting and fires.

Precautions for Moving Parts



- Stop the engine before you service it. If you must inspect while the engine is operating, never touch moving parts. Keep your body and clothing well clear of all moving parts as this could result in injury.

Precautions for Removing Hot Oil and Water to Prevent Burns



- If extracting oil from the engine while it is still hot, do not let the oil splash on you. To avoid getting scalded, wait until the temperature has dropped before removing cooling water from the engine.

[NOTICE] Do not alter the diesel engine.

Rebuilding the engine or altering parts to increase the speed or the amount of fuel discharged, etc., will make operation unsafe and result in damage and shortening of engine life.

[NOTICE] Disposal of waste materials

- Save oil or liquids to be disposed of in a container. Never dispose of waste oil or other fluids outside, in a sewer, river, or the sea.
- Treat waste materials safely observing all regulations and laws. Ask a waste recovery company to collect and dispose of it.

1

1.3 Location of Product Safety Labels

To insure safe operation, product safety labels have been attached. Their location is shown in the diagram below. Keep the labels from becoming dirty or torn and replace them if they are lost or damaged. Replace labels as well when parts are replaced, ordering them in the same manner as the parts.

Product Safety Labels Parts Code Numbers

①	128296-07300
②	128296-07240
③	128296-07360
④	128296-07260

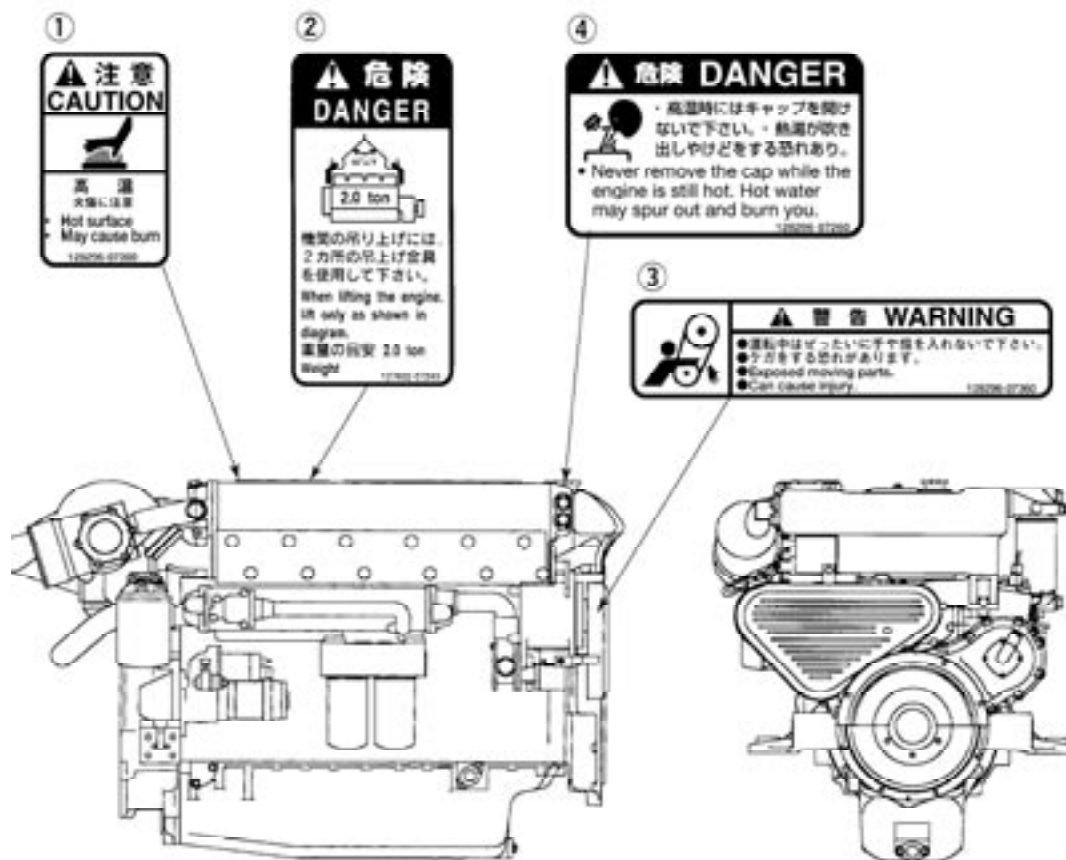

2

2.1 Use & Driving System

This is a light, compact diesel engine for use in pleasure boats. The engine is equipped with a turbocharger and an intercooler, which insures maximum output while preserving lightness and compact size. It is imperative that the size and structure of the boat be suited to the engine, in order to get full performance from your engine. It is equally important to use the correct driving device and a propeller of the appropriate size and specifications. The engine must be installed correctly with safe cooling water, exhaust piping and electrical wiring. The PTO work should be easy to use for onboard equipment. Consult your Yanmar dealer or distributor when selecting optional parts. When selecting optional parts, operational and surrounding conditions should be taken into account.

2

2.2 Engine Specifications

Engine Model		6CXM-GTE2
Use		Pleasure boat
Type		Vertical water-cooled 4-cycle diesel engine
Number of cylinders-Bore X strokemm		6-11 x 130
Displacement <i>l</i>		7.413
Aspiration system		Turbocharger
Cont. rating output kW(PS)/rpm		324(440) / 2800
High idling rpm		3250 ±25
Low idling rpm		750 ±25
Combustion system		Direct injection
Starting system		Electric Starting
Cooling system		Constant high temperature fresh water-cooling
Lubrication system		Forced lubrication system with gear pump
Direction of rotation (When viewed from stern side)	Crankshaft	Counterclockwise viewed from flywheel side
Fuel injection pump		In-line type
Fuel injection valve		Hole type
Turbocharger		Holset HX50
Electric devices	Starter	12V-4.8kW
	Alternator	12V-55A
	Battery	12V-200Ah
Lube oil capacity <i>l</i>	Engine oil (oil pan) Full/effective	22.8
Cooling water capacity	System	20
	Sub-tank	1.5
Dimension (LXWXH) mm		1190 x 805 x 905
Dry Mass kg		825

2

2.3 Location of Component

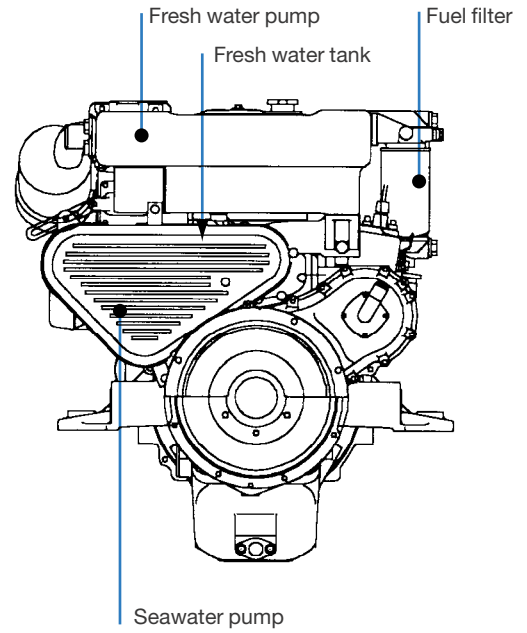
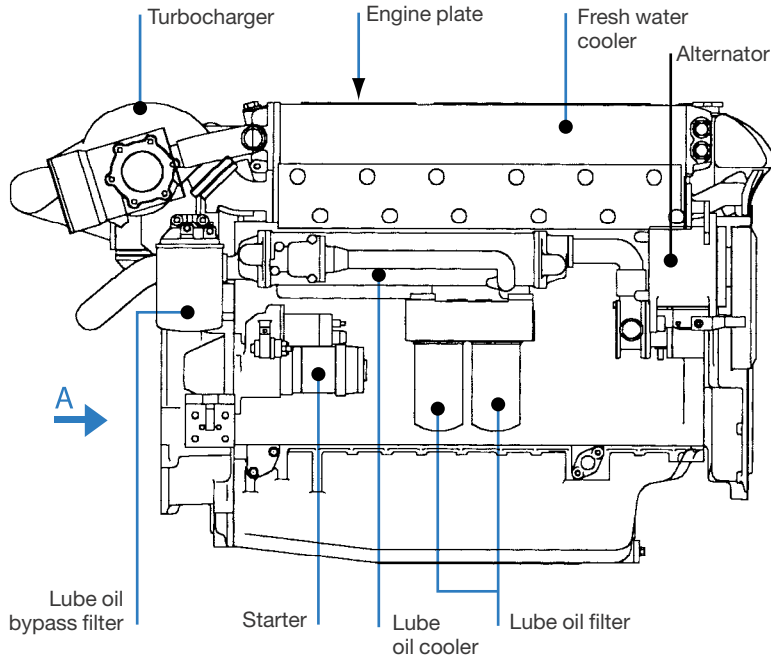

As seen from A

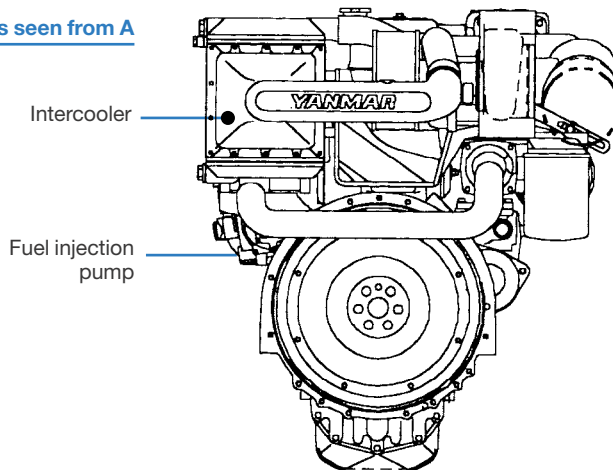

Thank you so much for reading.
Please click the “Buy Now!”
button below to download the
complete manual.



After you pay.

You can download the most
perfect and complete manual in
the world immediately.

Our support email:

ebooklibonline@outlook.com