

**YANMAR**

OPERATION MANUAL

# MARINE PROPULSION ENGINE

**6LY2M-WST  
6LY2M-WDT**

# CONTENTS

---

|  |           |
|--|-----------|
| <b>FOR YOUR SAFETY</b> .....                       | <b>1</b>  |
| Safety Symbols .....                               | 1         |
| Safety Precautions .....                           | 2         |
| Warning Labels .....                               | 5         |
| Precautions for Lifting the Engine .....           | 7         |
| Engine Nameplates .....                            | 8         |
| <b>SPECIFICATIONS</b> .....                        | <b>9</b>  |
| Location of Components .....                       | 10        |
| <b>FUEL OIL, LUBRICATING OIL AND COOLANT</b> ..... | <b>12</b> |
| Fuel .....   | 12        |
| Lubricating Oil .....                              | 13        |
| Coolant .....                                      | 14        |
| <b>RUNNING-IN</b> .....                            | <b>15</b> |
| Fuel .....   | 15        |
| Lubricating Oil .....                              | 17        |
| Cooling System (Seawater and Coolant) .....        | 18        |
| Lubrication .....                                  | 20        |
| Remote Control Device (Option).....                | 20        |
| Cranking .....                                     | 20        |
| Instruments Check before Starting.....             | 21        |
| Rechecking after Starting.....                     | 23        |
| <b>OPERATION</b> .....                             | <b>24</b> |
| Starting .....                                     | 24        |
| Notice while Running with Load .....               | 27        |
| Stopping .....                                     | 29        |
| Long-Term Storage .....                            | 30        |
| <b>PERIODICAL MAINTENANCE</b> .....                | <b>31</b> |
| Periodic Maintenance Schedule .....                | 31        |
| Fuel System .....                                  | 33        |
| Lubricating Oil System .....                       | 34        |
| Cooling Water System (Seawater and Coolant) .....  | 36        |
| Checking and Servicing the Turbocharger .....      | 39        |
| Remote Control Cables .....                        | 40        |
| Electrical Parts .....                             | 41        |
| Valve Clearance Adjustment .....                   | 41        |
| <b>TROUBLESHOOTING AND COUNTERMEASURES</b> .....   | <b>42</b> |
| <b>SYSTEM DIAGRAMS</b> .....                       | <b>46</b> |
| Piping Diagrams .....                              | 46        |
| Wiring Diagrams .....                              | 50        |

# FOR YOUR SAFETY

---

Following the precautions described in this manual will enable you to use this engine with complete satisfaction. Failure to observe any of the rules and precautions, however, may result in injury, burns, fires and engine damage. Read this manual carefully and be sure you fully understand it before beginning operation.

## Safety Symbols

These are the warning signs used in this manual and on the product.



This safety alert symbol appears with most safety statements. It means attention, become alert, your safety is involved! Please read and abide by the message that follows the safety alert symbol.

 **DANGER**

**DANGER** indicates a hazardous situation which, if not avoided, will result in death or serious injury.

 **WARNING**

**WARNING** indicates a hazardous situation which, if not avoided, could result in death or serious injury.

 **CAUTION**

**CAUTION** indicates a hazardous situation which, if not avoided, could result in minor or moderate injury.

**NOTICE**

**NOTICE** indicates a situation which can cause damage to the machine, personal property and/or the environment or cause the equipment to operate improperly.

# Safety Precautions

## Safety precautions for operation

### DANGER



#### Burns from steam

- Never remove the filler cap from the coolant tank while the engine is still hot. Steam and hot air will spurt out and seriously burn you. After engine stop, wait until the water temperature drops. Wrap a cloth around the filler cap and slowly loosen the cap.
- After inspection, tighten the filler cap firmly. If the cap is not secure, steam or hot air can spurt out during operation and seriously burn you.



#### Ventilation of the battery area

- Make sure that the area around the battery is well-ventilated and that no flammable materials are near. The battery emits hydrogen gas during operation and charging. The gas can catch fire.



#### Fires from oil ignition

- Be sure to use the correct type of fuel oil. Always double-check before fueling. The wrong fuel oils (e.g. gasoline) can cause a fire.
- Be sure to stop the engine before fueling. If you spill fuel oil, wipe the spillage carefully.
- Keep oil and other inflammable materials away from the engine. They can catch fire.

### WARNING



#### Exhaust gas poisoning

- Never cover or block the windows, air vents, fans or other ventilation devices in the engine room. Always maintain good ventilation in the engine room during operation. Breathing exhaust gas is dangerous to your health.



#### Moving parts

- Keep your hands, other body parts and clothing away from moving parts (e.g. the front drive shaft, V-belt or propeller shaft). You will get caught and injured.
- Never operate the engine without the covers on the moving parts.
- Before engine start, check that you removed all tools and cloths from the area near the engine.



#### Alcohol and drugs

- Never operate the engine while you are under the influence of alcohol or drugs. Never operate the engine when you feel ill or unwell.

**⚠ CAUTION**



**Burns**

- Be careful of burns. The entire engine is very hot during and after operation.
- Keep your hands, other body parts and clothing away from the exhaust manifold, exhaust pipes, turbocharger, air cooler and engine body.

## Safety precautions for maintenance

**⚠ DANGER**



**Burns from steam**

- Never remove the filler cap from the coolant tank while the engine is still hot. Steam and hot air will spurt out and seriously burn you. After engine stop, wait until the water temperature drops. Wrap a cloth around the filler cap and slowly loosen the cap.
- After inspection, tighten the filler cap firmly. If the cap is not secure, steam or hot air can spurt out during operation and seriously burn you.



**Fires from oil ignition**

- Be sure to use the correct type of fuel oil. Always double-check before fueling. The wrong fuel oils (e.g. gasoline) can cause a fire.
- Be sure to stop the engine before fueling. If you spill fuel oil, wipe the spillage carefully.
- Keep oil and other inflammable materials away from the engine. They can catch fire.

**⚠ WARNING**



**Fires from electric short-circuits**

- Always turn off the battery switch or detach the earth cable (-) before you inspect the electrical system. If you cause a short-circuit, a fire can occur.



**Moving parts**

- Stop the engine before you inspect it. If you have no choice but to inspect the engine while it operates, keep your hands, other body parts and clothing away from rotating parts. You will get caught and injured.



**Exhaust gas poisoning**

- Never cover or block the windows, air vents, fans or other ventilation devices in the engine room. Always maintain good ventilation in the engine room during operation. Breathing exhaust gas is dangerous to your health.

**⚠ WARNING****Side cover opening**

- Do not open the side cover when the engine is hot. The new air intrusion may lead to an explosion.

**⚠ CAUTION****Battery fluid**

- Be very careful not to expose your skin or eyes to the battery electrolyte. The electrolyte is a strong acid and can cause inflammations. If you come in contact with the battery fluid, wash it off immediately with a lot of freshwater.

**Burns**

- Be careful of burns. The entire engine is very hot during and after operation.
- Keep your hands, other body parts and clothing away from the exhaust manifold, exhaust pipes, turbocharger, air cooler and engine body.

**NOTICE****No modification**

To keep the engine in good condition, the engine has been sealed to control the engine speed limit and the fuel injection quantity. If a seal is removed, the sliding and moving parts of the engine will suffer from increased wear. Engine performance will deteriorate and service life may shorten significantly. Removing a seal may also lead to increased lubricating oil and fuel consumption, seizure and breakage in all portions of the engine. Therefore, do not remove any seals. If the seal is removed, no warranty will be given even during the warranty period.

**Regulation on NOx**

Laws on maritime pollution and hazard prevention regulate the replacement of certain parts. The laws require that a record and the signature of personnel who replaces these parts is kept. All inspections and maintenance must be performed by our professional service technicians with the necessary expertise and skills.

**Waste disposal**

- Never dispose of waste oil, such as lubricating oil, by dumping it into a sewer, river, lake or ocean waters.
- Do not spill waste oil into ocean waters. Use a container to collect waste oil from the engine.
- Comply with relevant laws and/or regulations for the disposal of hazardous materials such lubricating oil, fuel, filters or batteries.

# Warning Labels

For safe operation, the affixed position of the warning labels is indicated.

Read the remarks of the warning labels carefully to attempt prevention of the accident.

Also, if you need to replace a part that has a label affixed to it, make sure you order the new part and label at the same time.

If the warning labels are damaged or fallen, order them from your authorized YANMAR dealer or distributor.

## ■ Operation side

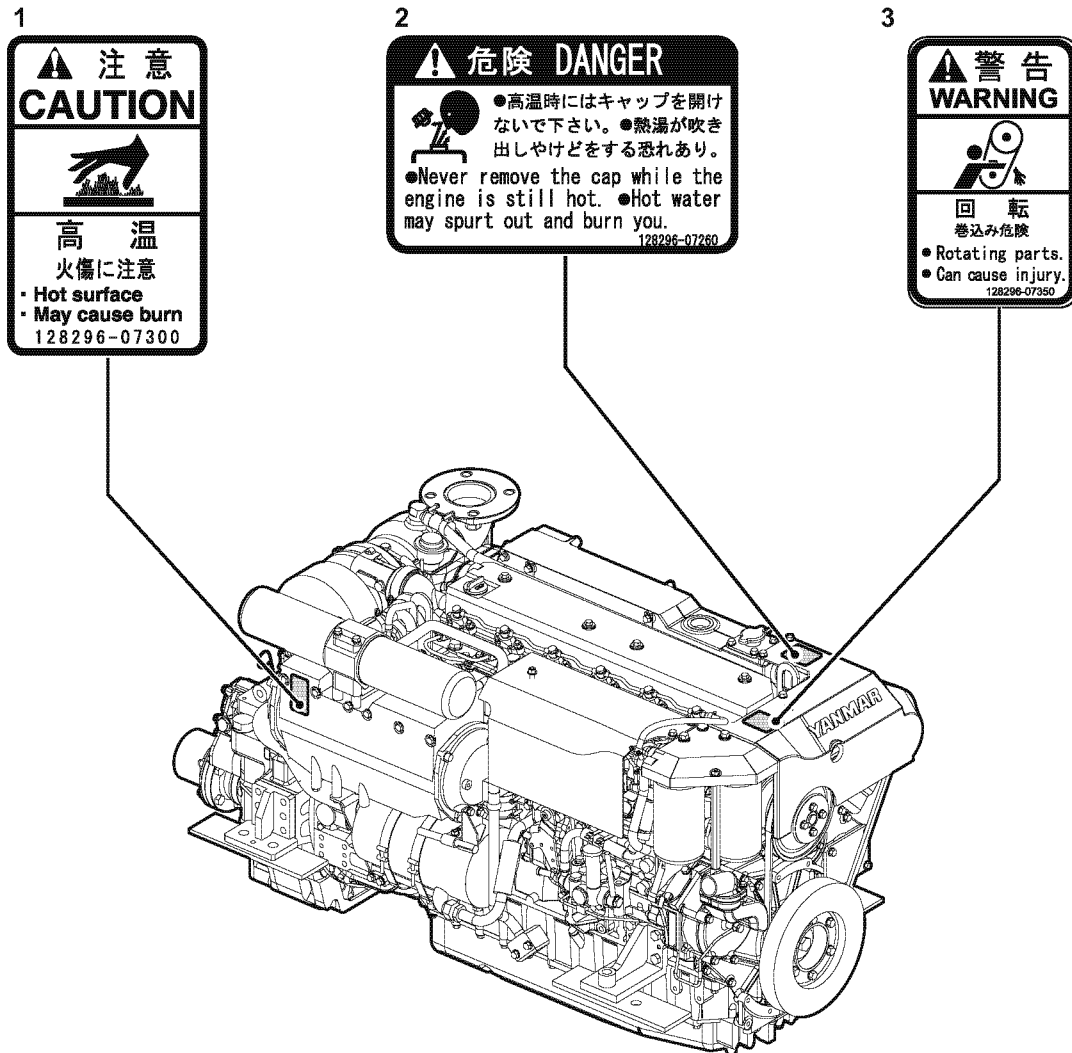

| No. | Part No.     |
|-----|--------------|
| 1   | 128296-07300 |
| 2   | 128296-07260 |
| 3   | 128296-07350 |

■ Non-operation side

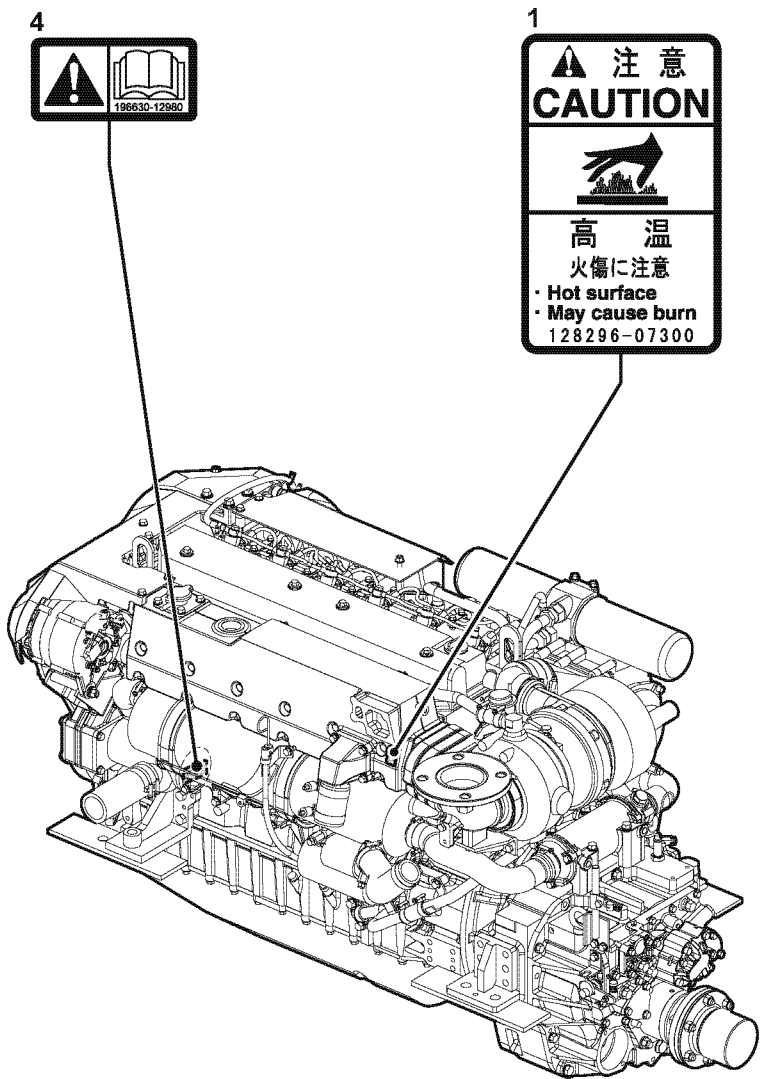

| No. | Part No.     |
|-----|--------------|
| 1   | 128296-07300 |
| 4   | 196630-12980 |

062629-01X00

## Precautions for Lifting the Engine

The engine can cause serious injury when it falls during lifting. Obey the below instructions to prevent accidents during lifting.

### **⚠ WARNING**

- Make sure that the engine is lifted by qualified persons.
- Before lifting, make sure that the engine lifting bracket and mounting bolt have no damage and are in good shape. If you find a fault, stop immediately and contact your authorized YANMAR dealer or distributor.
- Select lifting tools (e.g. wire rope and shackle) that are appropriate for heavy loads.
- Select the wire rope length so that the engine does not tilt during lifting.
- Before lifting, examine the lifting tools and make sure that they have no damage and are in good shape.
- Protect the parts of the engine or driven equipment that touch the wire rope with protective material.
- The tension of the wire rope changes depending on the lifting angle. Make sure that the angle is within 60°.
- If you use a marine gear that is not listed in this operation manual, separate the marine gear from the engine, and lift the marine gear and engine separately.
- During lifting and moving the engine, do not go under the engine or near the engine.

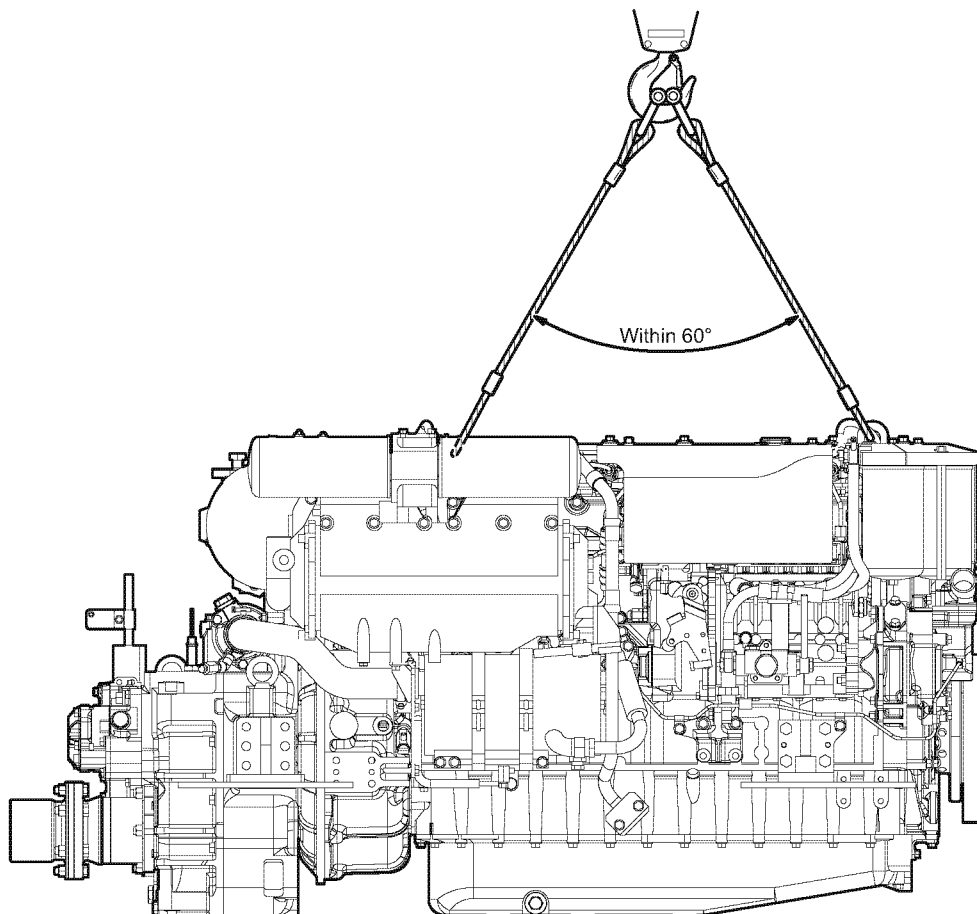

062631-00EN00

For the mass, refer to Specifications in the Operation Manual.

Thank you so much for reading.  
Please click the “Buy Now!”  
button below to download the  
complete manual.



After you pay.

You can download the most  
perfect and complete manual in  
the world immediately.

Our support email:

[ebooklibonline@outlook.com](mailto:ebooklibonline@outlook.com)