

## GLP/GDP16-20AF/BF (A810)

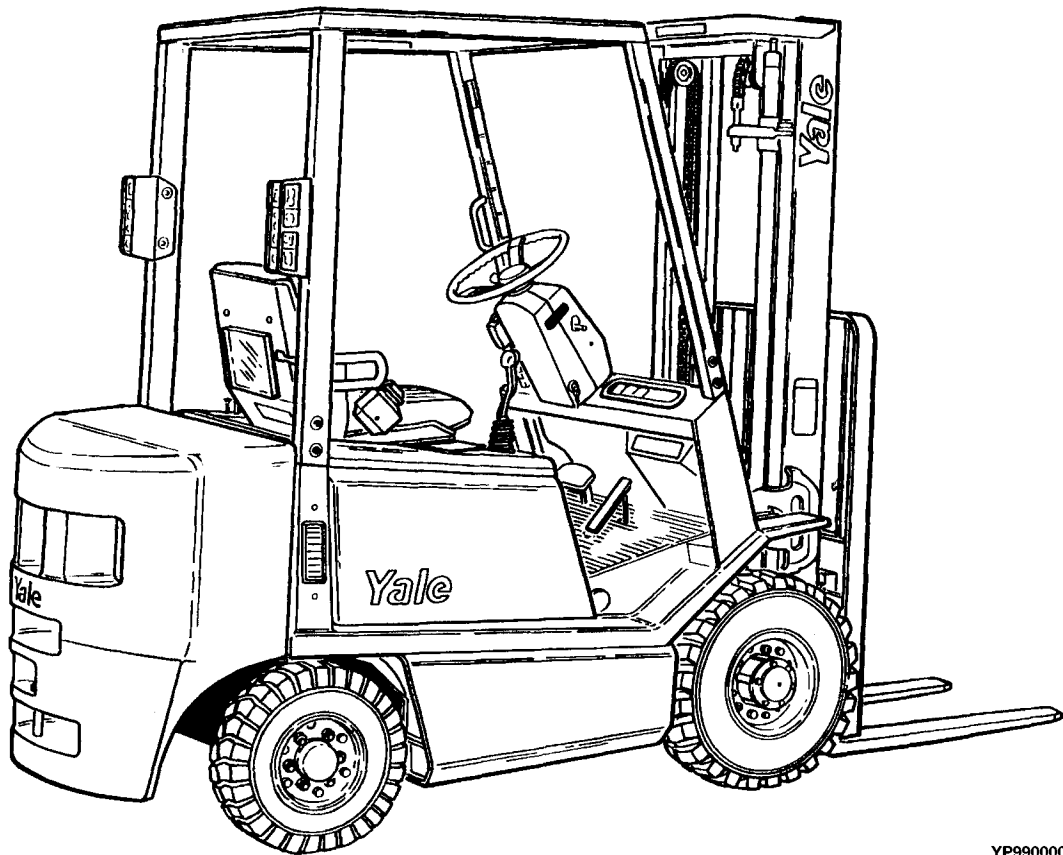

YP990000

<b>1</b>	<b>GENERAL TRUCK</b>	
<b>2</b>	<b>DIESEL ENGINE (2.5L)</b>	
<b>3</b>	<b>LPG ENGINE (1.5L)</b>	
<b>4</b>	<b>LPG ENGINE (2.0L)</b>	
<b>5</b>	<b>FUEL SYSTEM</b>	
<b>6</b>	<b>ELECTRICAL SYSTEM</b>	
<b>7</b>	<b>STEERING SYSTEM</b>	
<b>8</b>	<b>BRAKE SYSTEM</b>	
<b>9</b>	<b>TRANSMISSION</b>	
<b>10</b>	<b>HYDRAULIC SYSTEM</b>	
<b>11</b>	<b>MAST-TWO STAGE LIMITED FREE-LIFT</b>	
<b>12</b>	<b>MAST-THREE STAGE FULL FREE-LIFT</b>	
<b>13</b>	<b>MAST-TWO STAGE FULL FREE-LIFT</b>	
<b>14</b>	<b>FORKS, LOAD BACKREST, AND MAST INSTALLATION</b>	
<b>15</b>	<b>OPTIONS</b>	
<b>16</b>	<b>NUMERICAL INDEX</b>	

ALPHABETICAL INDEX

DESCRIPTION	PAGE NO.
<b>A</b>	
ABBREVIATIONS QUICK REFERENCE SHEET .....	ix
AIR FILTER	
GDP AF	
⇒S/N A810B-3831 .....	5.26
S/N A810B-3832⇒ .....	5.28
GP/GLP AF/BF	
⇒S/N A810B-3831 .....	5.24
ALPHABETICAL INDEX .....	i
ALTERNATOR .....	6.16
<b>B</b>	
BACK-UP ALARM .....	15.28
BATTERY .....	6.28
BRAKE ASSEMBLY	
⇒S/N A810B03647U .....	8.10
S/N A810B03648U⇒ .....	8.12
BRAKE LINES .....	8.14
BRAKE MASTER CYLINDER .....	8.16
BRAKE PEDAL LINKAGE	
⇒S/N A810B-2577 .....	8.2
S/N A810B-2578⇒ .....	8.6
<b>C</b>	
CAMSHAFT AND VALVES	
GDP AF .....	2.16
GP/GLP AF .....	4.16
GP/GLP BF .....	3.14
CARBURETOR	
GLP AF/BF .....	5.22
GP AF/BF .....	5.20
CARRIAGE	
SIX ROLLER	
THREE STAGE FULL FREE-LIFT .....	12.22
TWO STAGE FULL FREE-LIFT .....	13.20
TWO STAGE LIMITED FREE-LIFT .....	11.14
CONTROL VALVE	
D/B 08/2001⇒ .....	9.32
D/B 11/1998↔D/B 08/2001 .....	9.30
FOUR FUNCTION	
DUAL RELIEF VALVE	
⇒D/B 07/1996 .....	10.58
DUAL RELIEF VALVE WITH UNLOADER VALVE	
D/B 07/1996⇒ .....	10.62
SINGLE RELIEF	
⇒D/B 07/1996 .....	10.42
SINGLE RELIEF WITH UNLOADER VALVE	

DESCRIPTION	PAGE NO.
-------------	----------

**C** (continued)

D/B 07/1996⇒ .....	10.46
⇒S/N A810B-2577 .....	9.26
S/N A810B-2578⇔D/B 11/1998 .....	9.28
<b>THREE FUNCTION</b>	
<b>DUAL RELIEF VALVE</b>	
⇒D/B 07/1996 .....	10.50
<b>DUAL RELIEF VALVE WITH UNLOADER VALVE</b>	
D/B 07/1996⇒ .....	10.54
<b>SINGLE RELIEF</b>	
⇒D/B 07/1996 .....	10.30
<b>SINGLE RELIEF WITH UNLOADER VALVE</b>	
D/B 07/1996⇒ .....	10.38
<b>SINGLE RELIEF WITHOUT UNLOADER VALVE</b>	
D/B 07/1996⇒ .....	10.34
<b>CONTROL VALVE ATTACHING PARTS</b>	
<b>FOUR FUNCTION</b> .....	10.28
<b>THREE FUNCTION</b> .....	10.24
<b>COOLING</b>	
GDP AF .....	2.34
GP/GLP AF .....	4.28
GP/GLP BF .....	3.28
COUNTERWEIGHT .....	1.8
<b>CRANKSHAFT AND PISTON</b>	
GDP AF .....	2.18
GP/GLP AF .....	4.14
GP/GLP BF .....	3.12
<b>CYLINDER BLOCK</b>	
GP/GLP AF .....	4.10
GP/GLP BF .....	3.8
XA, GDP AF .....	2.12
<b>CYLINDER HEAD</b>	
GDP AF .....	2.14
GP/GLP AF .....	4.12
GP/GLP BF .....	3.10

**D**

DIFFERENTIAL .....	9.24
<b>DIRECTIONAL CONTROL PEDAL</b>	
D/B 02/1999⇒ .....	5.38
<b>DIRECTIONAL CONTROL PEDAL LINKAGE</b>	
D/B 02/1999⇒ .....	5.36
<b>DISTRIBUTOR</b>	
GP/GLP AF .....	6.12
GP/GLP BF .....	6.14
DRIVE AXLE .....	9.34
<b>DRIVE WHEEL AND TIRE</b>	
1060 MM .....	15.20
887 MM .....	

DESCRIPTION	PAGE NO.
<b>D (continued)</b>	
SHEET 1 OF 2 .....	15.10
SHEET 2 OF 2 .....	15.12
930 MM	
SHEET 1 OF 3 .....	15.14
SHEET 2 OF 3 .....	15.16
SHEET 3 OF 3 .....	15.18
WITH STUD .....	15.22
DRIVE, TURN, AND SIDELIGHTS.....	15.30
<b>E</b>	
<b>ELECTRICAL SYSTEM</b>	
COWL .....	6.8
GDP AF.....	6.6
2.5L .....	2.36
GP/GLP AF .....	6.2
2.0L .....	4.24
GP/GLP BF .....	6.4
1.5L .....	3.24
END PLATE .....	9.50
ENGINE COVER .....	1.6
<b>ENGINE MOUNT</b>	
GDP AF.....	2.2
GP/GLP AF	
⇒S/N A810B-2360.....	4.2
S/N A810B-2361⇒.....	4.4
GP/GLP BF .....	3.2
<b>EXHAUST MANIFOLD</b>	
GP/GLP BF .....	3.18
<b>F</b>	
FENDER.....	1.26
<b>FILTER AND LOCK-OFF VALVE</b>	
GLP AF/BF.....	5.10
FIRE EXTINGUISHER .....	15.40
<b>FLYWHEEL AND TORQUE CONVERTER</b>	
D5, GP/GLP BF	
⇒S/N A810B-2577 .....	3.30
S/N A810B-2578⇒.....	3.32
FE, GP/GLP AF	
⇒S/N A810B-02424S .....	4.30
S/N A810B-02425S⇒.....	4.32
XA, GDP AF	
⇒S/N A810B-2577 .....	2.8
S/N A810B-2578⇒.....	2.10
<b>FORK</b>	
1600 KG.....	14.4
2000 KG.....	14.5
FRAME AND FLOORPLATES.....	1.2

DESCRIPTION	PAGE NO.
-------------	----------

**F** (continued)

FREE-LIFT	
THREE STAGE FULL FREE-LIFT .....	12.14
TWO STAGE FULL FREE-LIFT .....	13.10
FREE-LIFT CYLINDER	
THREE STAGE FULL FREE-LIFT .....	12.20
TWO STAGE FULL FREE-LIFT .....	13.18
FUEL FILTER	
GDP AF .....	2.28
FUEL SYSTEM	
GDP AF .....	2.26
GLP AF/BF .....	5.8
GP/GLP AF .....	4.26
GP/GLP BF .....	3.26
FUEL TANK AND LINES	
GDP AF .....	5.6
GP AF/BF .....	5.2
FULL SUSPENSION SEAT	
D/B 01/2000⇒ .....	1.17

**G**

GEAR PUMP	
S/N A810B-07073Y⇒ .....	9.48
⇒S/N A810B-2577 .....	9.44
S/N A810B-2578↔S/N A810B-07072Y .....	9.46
GOVERNOR	
GP/GLP AF/BF .....	5.18

**H**

HEADER HOSE	
FOUR FUNCTION	
THREE STAGE FULL FREE-LIFT .....	12.28
TWO STAGE FULL FREE-LIFT .....	13.26
TWO STAGE LIMITED FREE-LIFT .....	11.18
THREE FUNCTION	
THREE STAGE FULL FREE-LIFT .....	12.24
TWO STAGE FULL FREE-LIFT .....	13.22
TWO STAGE LIMITED FREE-LIFT .....	11.16
HOOD LATCH .....	1.28
HOW TO FIND THE DESIRED PART NUMBER .....	xi
HOW TO USE THE ILLUSTRATED PARTS MANUAL .....	xi
HYDRAULIC CLUTCH	
FORWARD/REVERSE	
S/N A810B-07073Y⇒ .....	9.22
⇒S/N A810B-2577 .....	9.18
S/N A810B-2578↔S/N A810B-07072Y .....	9.20
HYDRAULIC PUMP	
DOUBLE GEAR	
GDP AF	

DESCRIPTION	PAGE NO.
<b>H (continued)</b>	
⇒S/N A810B-3179 .....	10.20
DUAL GEAR DIESEL .....	10.14
SINGLE GEAR	
GDP AF	
⇒S/N A810B-3179 .....	10.10
GP/GLP	
⇒S/N A810B-3179 .....	10.16
SINGLE PUMP	
GP/GLP	
S/N A810B-3180⇒ .....	10.18
SINGLE PUMP DIESEL	
S/N A810B-3180⇒ .....	10.12
HYDRAULICS GROUP	
D/B 01/1995⇒ .....	10.6
⇒D/B 01/1995 .....	10.2
<b>I</b>	
IDENTIFICATION OF ATTACHMENT AND SIDE-SHIFT CARRIAGE SERIAL NUMBERS .....	xiv
IDENTIFICATION OF MAST SERIAL NUMBER .....	xiii
IDENTIFICATION OF TRUCK SERIAL NUMBER .....	xii
INJECTION PUMP	
GDP AF .....	2.32
INNER MAST	
THREE STAGE FULL FREE-LIFT .....	12.6
TWO STAGE FULL FREE-LIFT .....	13.4
TWO STAGE LIMITED FREE-LIFT .....	11.4
INSTRUMENT PANEL .....	6.26
INTAKE AND EXHAUST MANIFOLD	
GP/GLP AF .....	4.20
INTAKE MANIFOLD	
GP/GLP BF .....	3.20
INTERMEDIATE MAST	
THREE STAGE FULL FREE-LIFT .....	12.4
<b>L</b>	
LABELS AND PAINT .....	1.23
LIFT	
TWO STAGE LIMITED FREE-LIFT	
⇒S/N A550B-2249 .....	11.6
S/N A550B-2250⇒ .....	11.8
LIFT CYLINDER	
LEFT HAND	
TWO STAGE LIMITED FREE-LIFT .....	11.10
RIGHT HAND	
TWO STAGE LIMITED FREE-LIFT .....	11.12
LIFTING EYE .....	15.2
LOAD BACKREST EXTENSION .....	14.2
LPG CONVERTER	

DESCRIPTION	PAGE NO.
<b>L (continued)</b>	
AF/BF	
IDENTIFY BY CODE LETTER "J" .....	5.12
IDENTIFY BY CODE LETTER "K"	
⇒D/B 06/1998 .....	5.14
IDENTIFY BY CODE LETTER "K"	
D/B 06/1998⇒ .....	5.16
LPG TANK	
GLP AF/BF .....	5.4
<b>M</b>	
MAIN CYLINDER	
LEFT HAND	
THREE STAGE FULL FREE-LIFT .....	12.16
TWO STAGE FULL FREE-LIFT .....	13.14
RIGHT HAND	
THREE STAGE FULL FREE-LIFT .....	12.18
TWO STAGE FULL FREE-LIFT .....	13.16
MAIN LIFT	
THREE STAGE FULL FREE-LIFT	
⇒S/N A554B-2099 .....	12.8
S/N A554B-2100⇒ .....	12.12
TWO STAGE FULL FREE-LIFT	
⇒S/N A558B-1670 .....	13.6
S/N A558B-1671⇒ .....	13.8
MANIFOLD	
GDP AF .....	2.24
MAST INSTALLATION	
THREE STAGE FULL FREE-LIFT .....	12.32
TWO STAGE FULL FREE-LIFT .....	13.30
TWO STAGE LIMITED FREE-LIFT .....	11.22
<b>N</b>	
NOISE REDUCTION	
ENGINE COVER .....	1.30
FRAME .....	1.32
NON-SUSPENSION SEAT	
D/B 01/2000⇒ .....	1.20
NOZZLE HOLDER	
GDP AF .....	2.30
<b>O</b>	
OIL PUMP	
GDP AF .....	2.22
OIL PUMP AND FILTER	
GP/GLP AF .....	4.22
GP/GLP BF .....	3.22
OIL SUMP AND TIMING GEAR	
GP/GLP AF .....	4.18



DESCRIPTION	PAGE NO.
<b>O</b> (continued)	
ORBITROL UNIT .....	7.8
OUTER MAST	
THREE STAGE FULL FREE-LIFT .....	12.2
TWO STAGE FULL FREE-LIFT .....	13.2
TWO STAGE LIMITED FREE-LIFT .....	11.2
OVERHEAD GUARD .....	1.34
<b>P</b>	
PARK BRAKE LEVER .....	8.18
PUMP DRIVE	
GDP AF .....	10.66
GP/GLP BF/AF .....	10.68
<b>R</b>	
RADIATOR	
GDP AF .....	2.6
GP/GLP AF .....	4.8
GP/GLP BF .....	3.6
<b>S</b>	
SEAT ASSEMBLY .....	1.10
SHIFT LEVER .....	8.20
SIDE-SHIFT CARRIAGE .....	15.4
SIDE-SHIFT CYLINDER .....	15.8
SOLENOID VALVE .....	9.36
STARTER MOTOR	
GDP AF .....	6.24
GP/GLP AF	
⇒S/N A810B-05935W .....	6.18
S/N A810B-05936W⇒ .....	6.20
GP/GLP BF .....	6.22
STEERING COLUMN .....	7.2
STEERING CYLINDER	
D/B 07/1997⇒ .....	7.12
⇒D/B 07/1997 .....	7.10
STEERING TIRE AND WHEEL .....	15.24
WITH STUD .....	15.26
STROBE LIGHT .....	15.32
SUSPENSION SEAT .....	1.12
⇒D/B 01/2000 .....	1.14
<b>T</b>	
TAIL LIGHTS	
EARLY PRODUCTION .....	15.34
LATE PRODUCTION .....	15.36
THROTTLE LINKAGE	
GDP AF/BF .....	5.30

---

**DESCRIPTION** **PAGE NO.**

---

**T** (continued)

GLP AF/BF.....	5.34
GP AF/BF.....	5.32
TILT CYLINDER.....	10.22
<b>TIMING GEAR COVER AND OIL SUMP</b>	
GDP AF.....	2.20
GP/GLP BF.....	3.16
TRAIL AXLE.....	7.6
<b>TRANSMISSION GEARS</b>	
⇒S/N A810B-2577.....	9.14
S/N A810B-2578⇒.....	9.16
<b>TRANSMISSION HOUSING</b>	
⇒S/N A810B-2577.....	9.2
S/N A810B-2578↔S/N A810B-07072Y.....	9.6
S/N A810B-7073Y⇒.....	9.10
<b>TRANSMISSION HYDRAULIC LINES</b>	
⇒S/N A810B-2577.....	9.38
S/N A810B-2578↔S/N A810B-3078.....	9.40
S/N A810B-3079⇒.....	9.42

**U**

<b>UPSWEPT EXHAUST</b>	
GDP AF.....	2.4
GP/GLP AF.....	4.6
GP/GLP BF.....	3.4

**W**

<b>WIRE HARNESS</b>	
CHASSIS.....	6.30
TAIL LIGHT.....	15.38

## SECTION 1 GENERAL TRUCK

DESCRIPTION	PAGE
COUNTERWEIGHT .....	1.8
ENGINE COVER .....	1.6
FENDER .....	1.26
FRAME AND FLOORPLATES .....	1.2
FULL SUSPENSION SEAT	
D/B 01/2000⇒ .....	1.17
HOOD LATCH .....	1.28
LABELS AND PAINT .....	1.23
NOISE REDUCTION	
ENGINE COVER .....	1.30
FRAME .....	1.32
NON-SUSPENSION SEAT	
D/B 01/2000⇒ .....	1.20
OVERHEAD GUARD .....	1.34
SEAT ASSEMBLY .....	1.10
SUSPENSION SEAT .....	1.12
⇒D/B 01/2000 .....	1.14

# FRAME AND FLOORPLATES

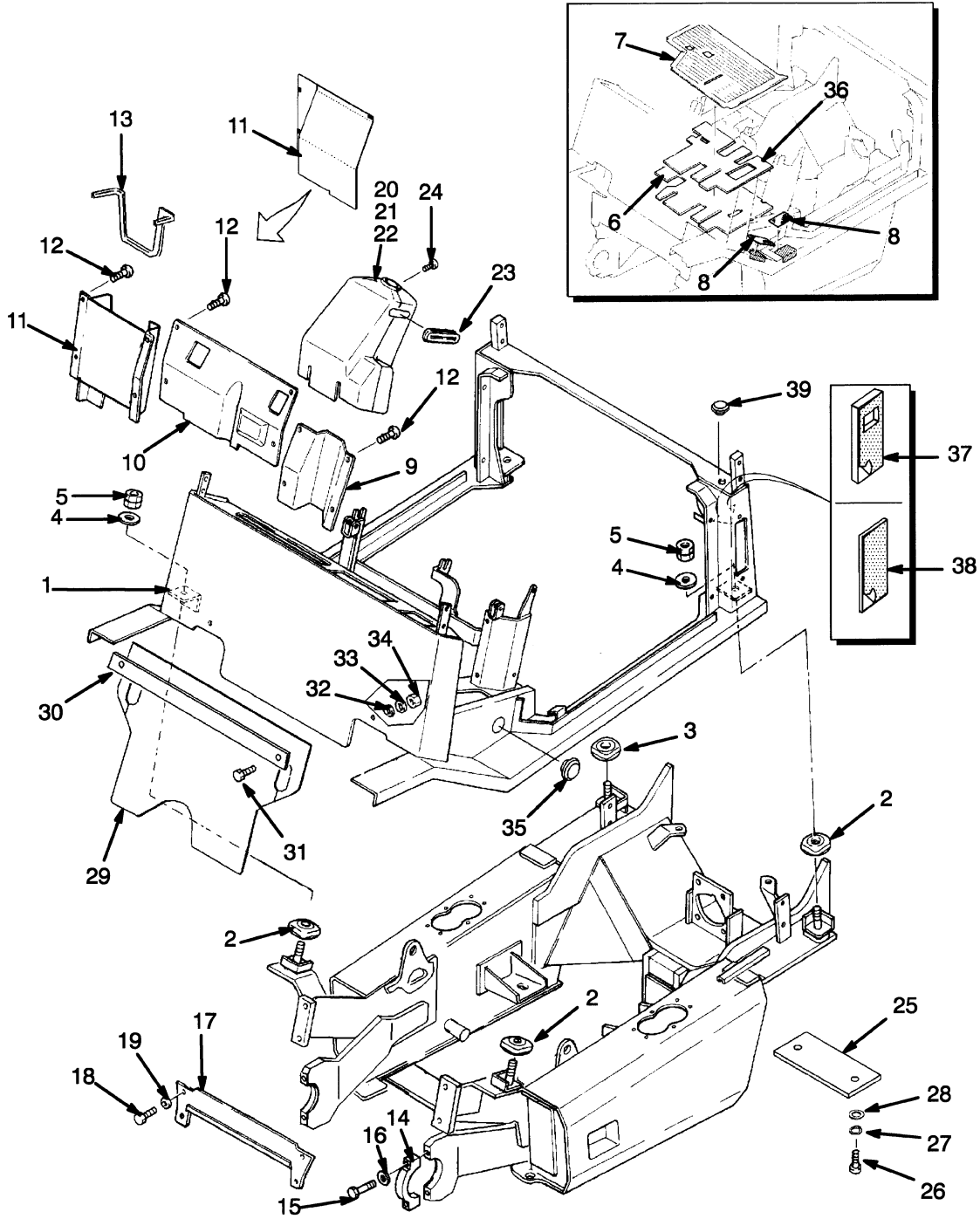

YP120001

ITEM	PART NO.	DESCRIPTION	QTY
1	<b>d</b> 906490700	Crossmember (Track Intermediate).....	1
1	906718700	Crossmember (Wide Track).....	1
2	916703300	Insulator.....	3
3	916704300	Insulator.....	1
4	909903402	Washer.....	4
5	907968405	Nut.....	4
6	<b>c</b> 923167401	Floorplate.....	1
6	<b>a</b> 926148400	Floorplate.....	1
7	<b>c</b> 904061701	Floormat.....	1
7	<b>c</b> 752171700	Floormat (Optional).....	1
7	<b>a</b> 907669705	Floormat.....	1
8	909472304	Anti-Slip Tread (Step).....	4
9	910279600	Cover (LH).....	1
10	912394600	Cover.....	1
11	<b>c</b> 919970401	Cover (RH).....	1
11	<b>a</b> 925730400	Cover.....	1
12	904184103	Screw.....	6
13	912291315	Trim.....	1
14	919920400	Cap.....	2
15	449001389	Capscrew.....	4
16	940101908	Washer.....	4
17	920127400	Plate.....	1
18	449001179	Capscrew.....	4
19	909903401	Washer.....	4
20	<b>c</b> 915483401	Cover Assembly.....	1
20	909950601	Cover (Rear).....	1
20	909951601	Cover (Front).....	1
21	<b>c</b> 915483402	Cover Assembly (LH).....	1
21	909950602	Cover (Rear).....	1
21	909951602	Cover (Front).....	1
22	915483403	Cover Assembly (without Shift Lever).....	1
22	909950603	Cover (Rear).....	1
22	909951603	Cover (Front).....	1
23	921698300	Boot.....	AR
23	<b>a</b> 934592300	Boot.....	1
24	909904403	Screw.....	5
25	921057300	Cover.....	2
26	449001302	Capscrew.....	4
27	449022013	Lockwasher.....	4
28	449021006	Washer.....	4
29	<b>b</b> 912875600	Cover (GP/GLP/GDP AF).....	1
30	<b>b</b> 922823300	Plate (GP/GLP/GDP AF).....	1
31	<b>b</b> 932729905	Capscrew (GP/GLP/GDP AF).....	2
32	<b>b</b> 904310402	Lockwasher (GP/GLP/GDP AF).....	2
33	449022016	Lockwasher (GP/GLP/GDP AF).....	2
34	<b>b</b> 449015014	Nut (GP/GLP/GDP AF).....	2
35	<b>b</b> 920600400	Cap.....	2
36	<b>b</b> 915163401	Pad (GP/GLP/GDP AF).....	1
37	<b>b</b> 922815301	Pad (LH on GP/GLP AF) (RH on GDP AF).....	1

**FRAME AND FLOORPLATES**

<b>ITEM</b>	<b>PART NO.</b>	<b>DESCRIPTION</b>	<b>QTY</b>
38	<b>b</b> 920053409	Pad (RH on GP/GLP AF) (LH on GDP AF) .....	1
39	<b>b</b> 910543108	Cap (GP/GLP/GDP AF/BF) .....	1

**FOOTNOTES:**

- a** Foot Directional Control Pedal
- b** Low Noise
- c** Shift Lever
- d** S/N A810B-2824 ⇒



# NOTES

---

---

---

---

---

---

---

---

---

---

---

---

---

---

---

---

---

---

---

---

---

---

---

ENGINE COVER

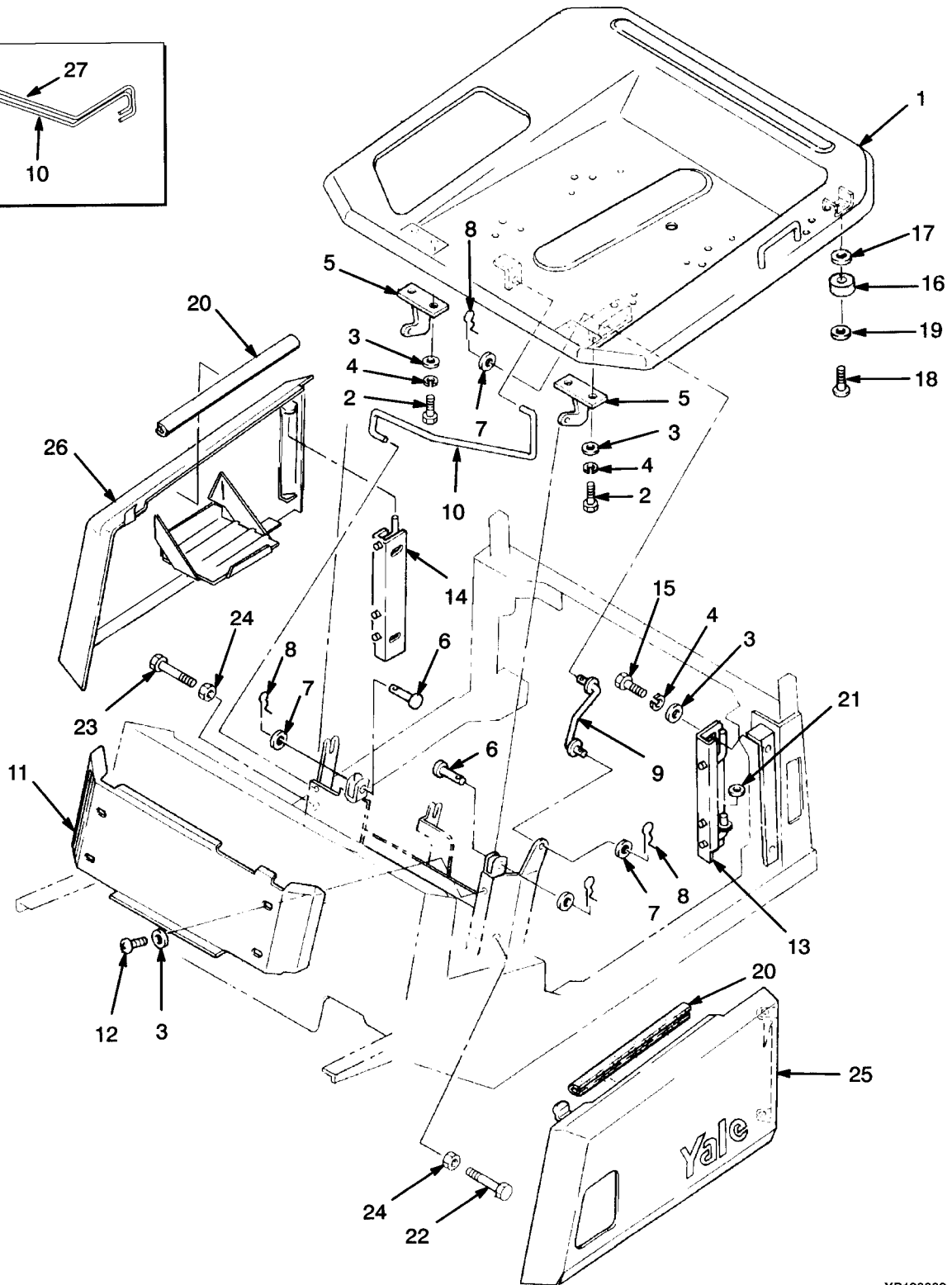
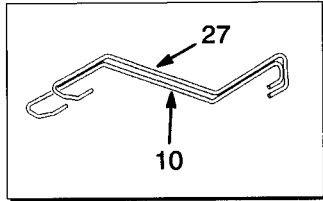

YP120002



ITEM	PART NO.	DESCRIPTION	QTY
1	908594716	Cover .....	1
2	449001013	Capscrew.....	4
3	023604600	Washer .....	12
4	449022016	Lockwasher .....	8
5	922307300	Hinge .....	2
6	912326300	Pin .....	2
7	449021006	Washer .....	4
8	965801908	Cotter Pin .....	4
9	922134300	Support.....	1
10	<b>a</b> 920546402	Torsion Spring .....	1
10	<b>b</b> 922650402	Spring .....	1
11	909835611	Plate .....	1
12	932729901	Capscrew.....	1
12	932729903	Capscrew.....	3
13	915340401	Hinge (LH) .....	1
14	915340402	Hinge (RH).....	1
15	449001415	Capscrew.....	4
16	917426300	Cushion (Rubber) .....	2
17	502398907	Washer .....	AR
18	580032373	Capscrew.....	2
19	449021001	Washer .....	2
20	912291312	Trim.....	2
21	449021006	Washer .....	AR
22	449001073	Capscrew.....	1
23	449001202	Capscrew.....	1
24	449015014	Nut.....	2
25	911834612	Door (LH) (GDP AF) .....	1
25	911833614	Door (LH) (GLP AF/BF) .....	1
25	911833613	Door (LH) (GP AF/BF) .....	1
26	912684612	Door (RH) (GDP AF) .....	1
26	912685612	Door (RH) (GP/GLP AF/BF) .....	1
27	<b>a</b> 920546401	Torsion Spring .....	1
27	<b>b</b> 922650401	Spring .....	1

**FOOTNOTES:**

**a** ⇒ S/N A810B-3179

**b** S/N A810B-3180 ⇒

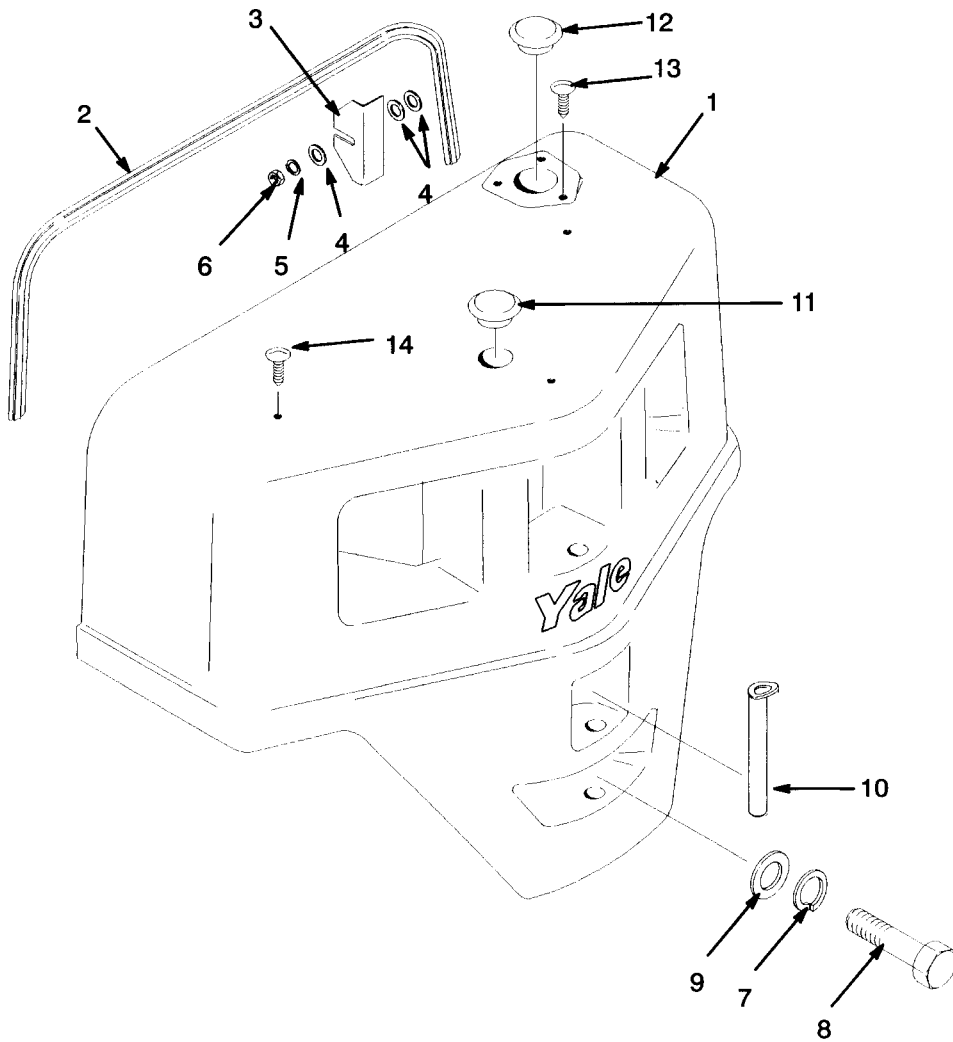

YP260603

ITEM	PART NO.	DESCRIPTION	QTY
1	905320700	Counterweight (GP/GLP 16 BF/AF, GDP 16 AF) .....	1
1	905322700	Counterweight (GP/GLP/GDP 20 AF) .....	1
2	900008212	Seal (1780 mm) .....	1
3	922410300	Shim .....	AR
4	449021001	Washer .....	4
5	449022016	Lockwasher .....	4
6	449015014	Nut .....	4
6	930113903	Screw .....	4
7	955400911	Lockwasher .....	2
8	449001405	Capscrew .....	2
9	910590100	Washer .....	2
10	924230300	Pin .....	1
11	917595300	Cap .....	1
12	920694401	Pad (GDP AF) .....	1
13	920695401	Pad (GDP AF) .....	2
14	920696401	Pad (GDP AF) .....	2
15	921773301	Pad (GDP AF) .....	4
16	916731401	Pad (GDP AF) .....	1
17	917595300	Cap .....	1
18	504241795	Fastener .....	3
19	504241795	Fastener (GP/GDP AF/BF) .....	3

SEAT ASSEMBLY

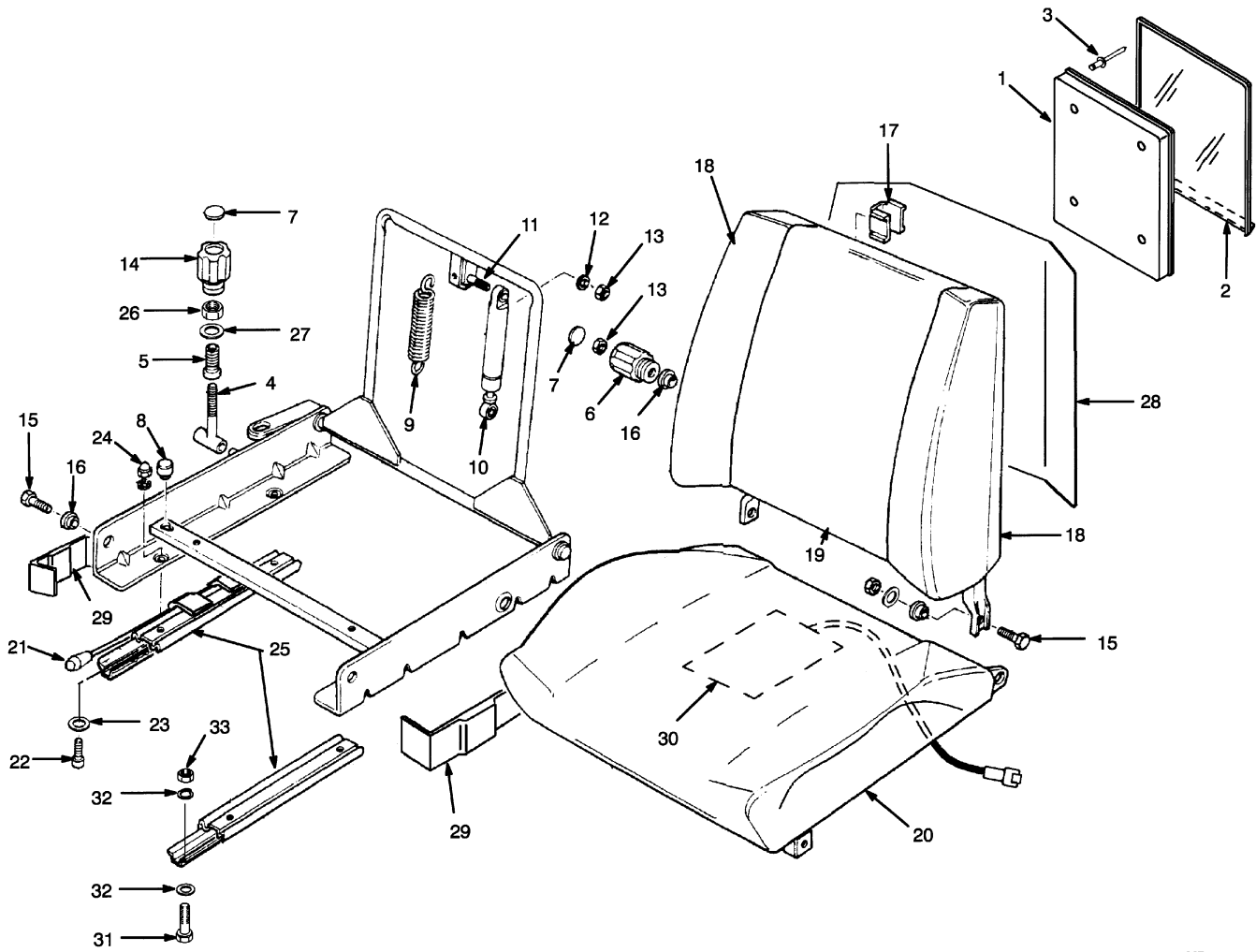

YP120004

ITEM	PART NO.	DESCRIPTION	QTY
	504241787	Seat .....	1
1	519996802	Base .....	1
2	519996803	Cover .....	1
3	505964587	Rivet .....	4
4	440063718	Screw .....	1
5	440063708	Bushing .....	1
6	440063707	Knob .....	1
7	440063712	Cover .....	2
8	440063719	Stop .....	2
9	440063710	Spring .....	1
10	440063711	Shock Absorber .....	1
11	505964575	Screw .....	2
12	449021001	Washer .....	10
13	440063720	Nut .....	10
14	440063706	Knob .....	1
15	449001415	Capscrew .....	4
16	440063703	Bushing .....	5
17	440063705	Wear Strip .....	2
18	505959574	Back Cushion (RH) .....	1
18	505964548	Back Cushion (LH) .....	1
19	505959545	Back Cushion (Center) .....	1
20	505964570	Seat Cushion .....	1
21	440063713	Knob .....	1
22	449002026	Screw .....	4
23	449023019	Washer .....	4
24	440063721	Nut .....	4
25	505964536	Seat Rail (LH) .....	1
25	505964584	Seat Rail (RH) .....	1
26	505964560	Nut .....	1
27	505964528	Washer .....	1
28	505964547	Cover .....	1
29	505964517	Cover (RH) .....	1
29	505964581	Cover (LH) .....	1
30	505964574	Switch .....	1
31	062232800	Capscrew .....	4
32	023604600	Washer .....	4
33	501831902	Nut .....	4

SUSPENSION SEAT

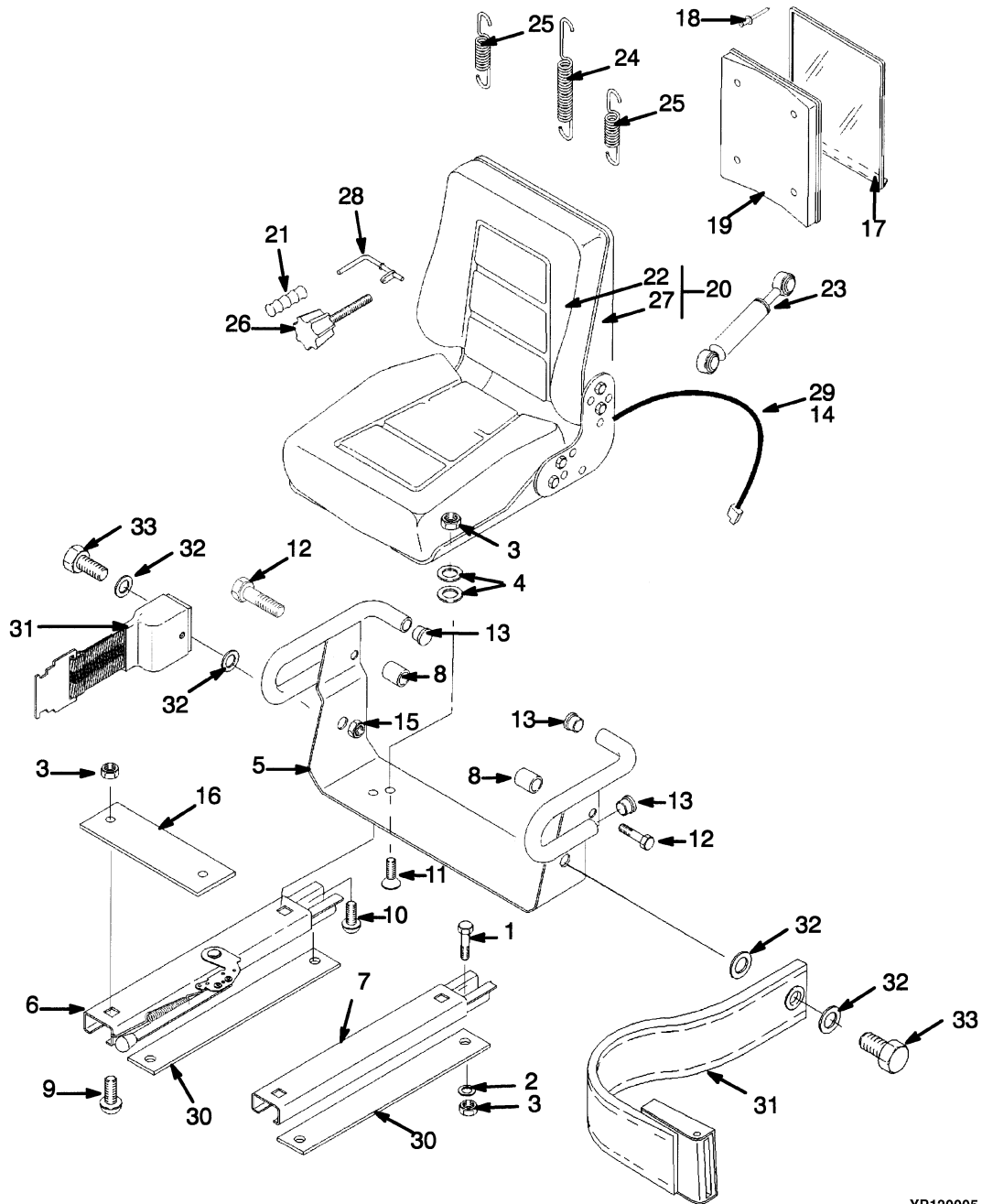

YP120005



SUSPENSION SEAT

ITEM	PART NO.	DESCRIPTION	QTY
1	062232800	Capscrew.....	4
2	023604600	Washer .....	4
3	501831902	Nut.....	8
4	016103700	Washer .....	4
5	505975564	Hip Restraint.....	1
6	505974541	Seat Rail (LH).....	1
7	505974582	Seat Rail (RH).....	1
8	505974509	Spacer .....	2
9	501753902	Capscrew.....	2
10	505974536	Capscrew.....	2
11	074259300	Capscrew.....	2
12	505974591	Capscrew.....	2
13	504226209	Plug .....	4
14	518793611	Wire Harness.....	1
15	504223224	Nut.....	2
16	505974524	Plate .....	1
17	519996803	Cover .....	1
18	501904909	Rivet .....	4
19	519996802	Base .....	1
20	505974567	Seat (Vinyl).....	1
21	440066253	Knob.....	1
22	440066256	Back Cushion (Vinyl).....	1
23	504224203	Shock Absorber.....	1
24	504224286	Spring.....	1
25	504224273	Spring.....	2
26	504224254	Spindle (Adjuster).....	1
27	150019502	Seat Pan.....	1
28	504237273	Lever .....	1
29	518793698	Switch.....	1
30	752821400	Spacer .....	1
31	518796683	Seat Belt.....	1
32	504223217	Washer .....	4
33	504223249	Capscrew.....	2

## SUSPENSION SEAT (⇒D/B 01/2000)

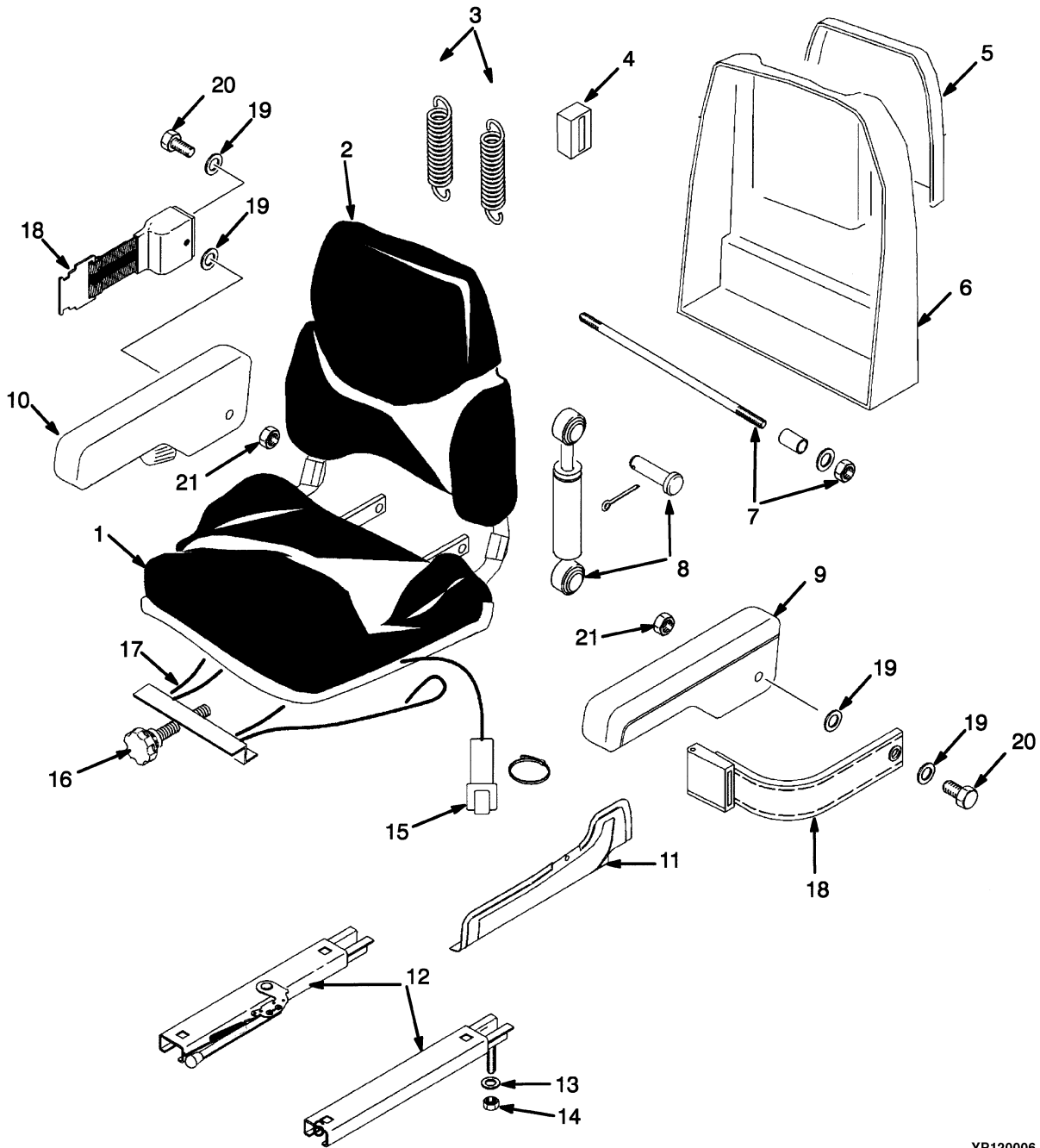

YP120006



ITEM	PART NO.	DESCRIPTION	QTY
	524135655	Seat Assembly (Vinyl Cover) .....	1
	258982309	Seat Assembly (Fabric Cover) .....	1
1	580002282	Seat Cushion (Vinyl) .....	1
2	504289704	Back Cushion (Vinyl) .....	1
3	520041644	Suspension Spring Kit.....	1
4	520041870	Block .....	1
5	580010469	Holder (Operator Manual) .....	1
6	580010679	Cover (Back) .....	1
7	520041896	Shaft and Bearing Kit.....	1
8	520041836	Shock Absorber Kit .....	1
9	580010467	Armrest (LH).....	1
10	580010468	Armrest (RH).....	1
11	580008947	Cover (RH) .....	1
11	580008948	Cover (LH).....	1
12	580010435	Slide Kit .....	1
13	023604600	Washer .....	4
14	504238298	Nut.....	4
15	504305734	Switch Assembly .....	1
16	520041829	Knob Kit.....	1
17	520041883	Suspension Cable Kit.....	1
18	580008934	Seat Belt.....	1
19	.....	Washer .....	4
20	.....	Bolt .....	2
21	.....	Nut.....	2

## FULL SUSPENSION SEAT (D/B 01/2000⇒)

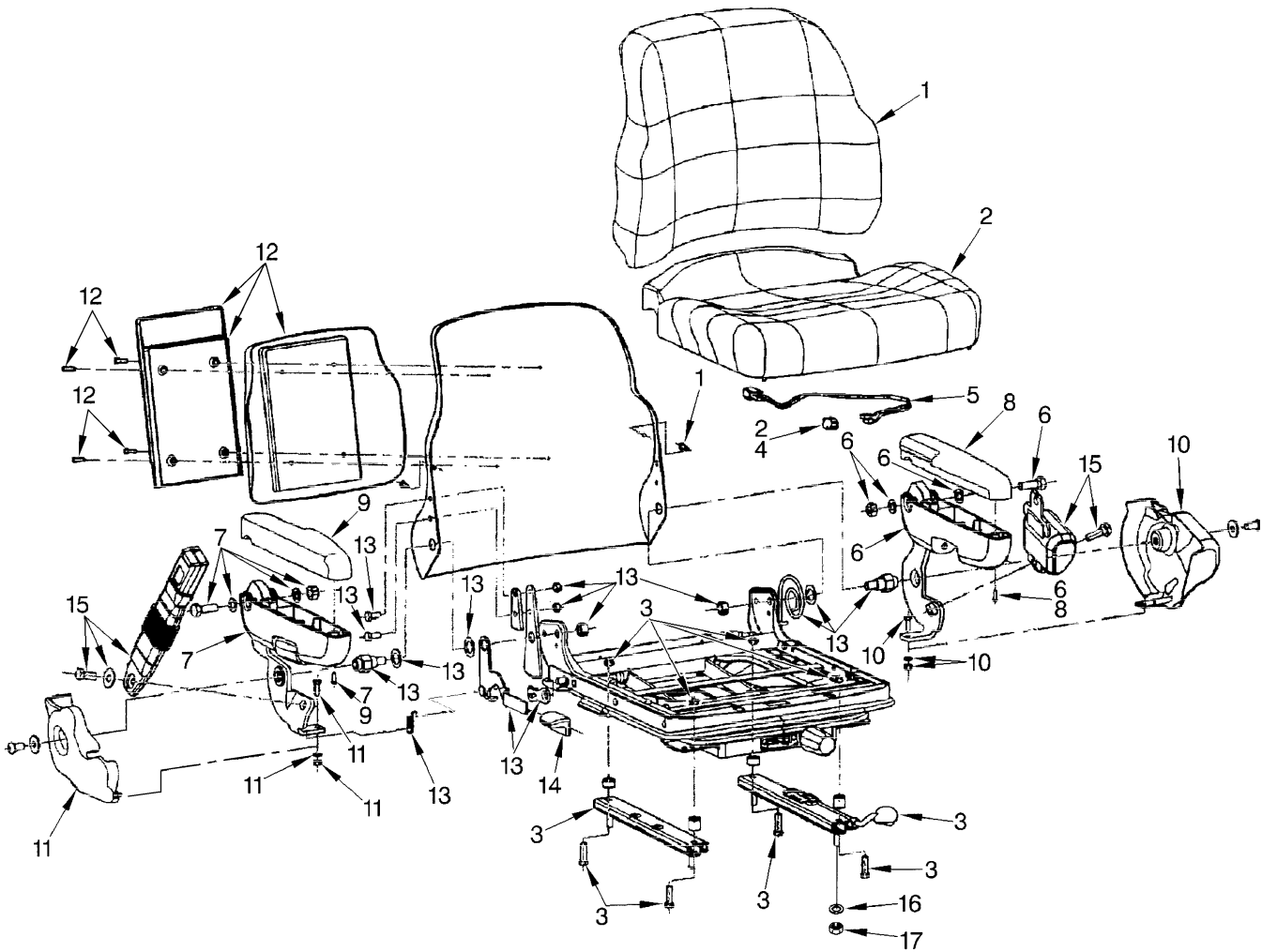

YP120007

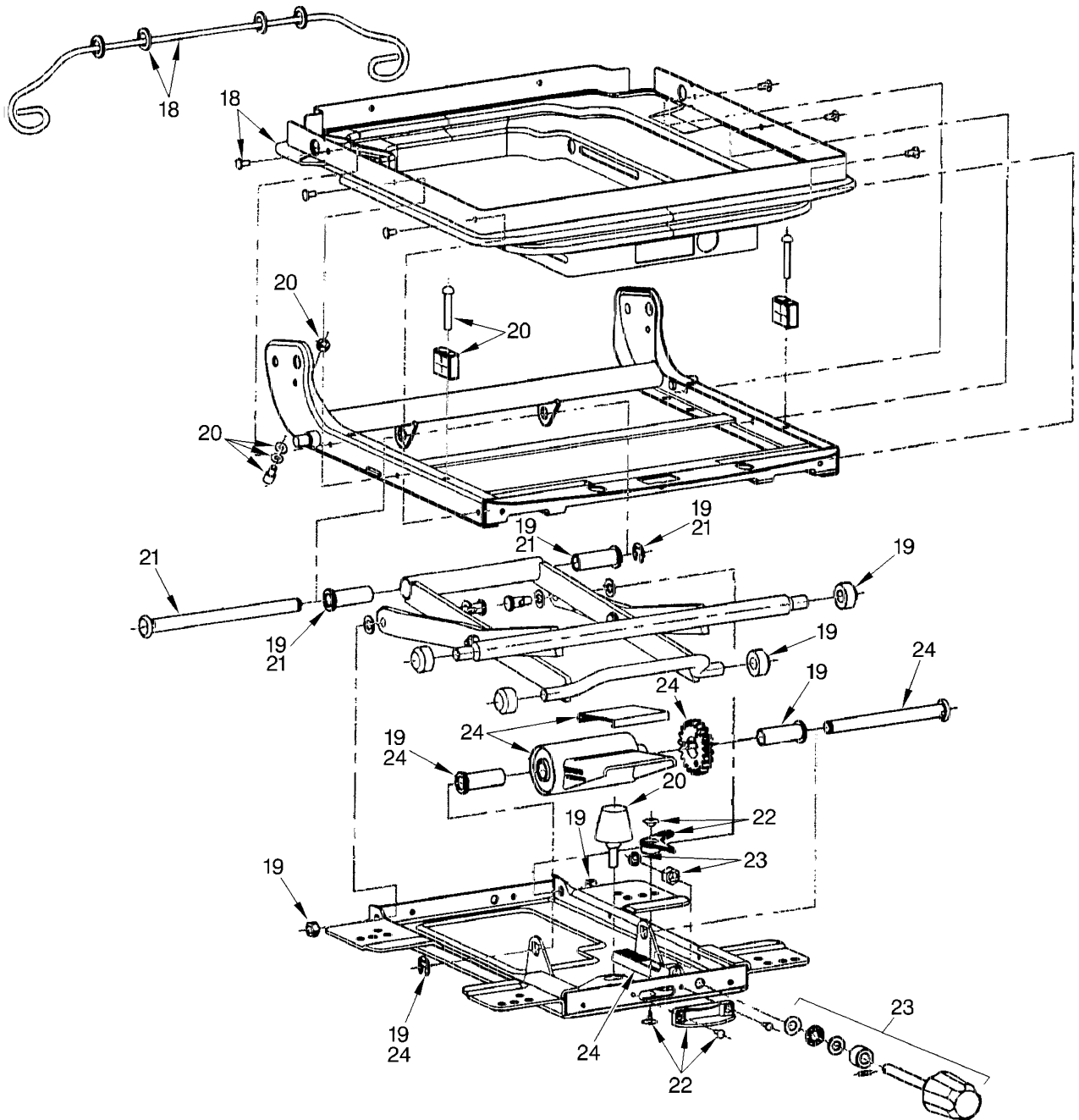

YP120008

Thank you so much for reading.  
Please click the “Buy Now!”  
button below to download the  
complete manual.



After you pay.

You can download the most  
perfect and complete manual in  
the world immediately.

Our support email:

[ebooklibonline@outlook.com](mailto:ebooklibonline@outlook.com)